

---

TECHNICAL MANUAL

GENERAL  
MAINTENANCE  
PROCEDURES

HAND TOOLS

GENERAL  
MAINTENANCE PROCEDURES  
FOR  
FIRE CONTROL MATERIEL

MEASUREMENT  
AND  
MECHANICAL DATA

CABLES,  
HARNESSES,  
AND CONNECTORS

ELECTRONIC  
DATA

ELECTRONIC  
TEST  
EQUIPMENT

OPTICAL  
DATA

FIRE CONTROL  
TEST EQUIPMENT

This copy is a reprint which includes current pages from changes 1 through 5.

HEADQUARTERS. DEPARTMENT OF THE ARMY

---

13 AUGUST 1984

**WARNING**

Appropriate safety precautions must be taken while using cleaning materials that may present fire hazards, cause skin irritations, or have toxic effect when breathed in high vapor concentrations.

**WARNING**

High pressure nitrogen gas is used during purging and charging of this equipment. Keep face and body clear of release valves. Failure to observe safety precautions may result in severe injury or death.

**WARNING**

Use adhesives, cleaning solvents, and sealing compounds in well-ventilated area away from open flame. Adhesives, cleaning solvents, and sealing compounds are harmful to skin and clothing, can burn easily, and may give off harmful vapor.

**WARNING**

Solvent vapors are toxic. Do not use solvent in a confined space. Avoid long periods of breathing solvent vapors and/or contact with skin.

**WARNING**

Compressed air presents a serious hazard. When it is necessary to use compressed air for cleaning or drying, adequate controls must be taken to protect the user, adjacent operators, and casuals. The minimum amount of air pressure required to perform the specific operations must be used. All users of compressed air must wear eye protection. Compressed air will not be used for cleaning purposes except where reduced to less than 30 psig.

**WARNING**

High voltage is used in the operation of equipment in these procedures. Death on contact may result if personnel fail to observe safety precautions. For artificial respiration, refer to FM 21-11 (TEST).

Change

No. 6

HEADQUARTERS  
DEPARTMENT OF THE ARMY  
Washington, DC, 30 June 2000

**GENERAL MAINTENANCE PROCEDURES  
FOR  
FIRE CONTROL MATERIEL**

TM 9-254, 13 August 1984, is changed as follows:

1. Remove old pages and insert new pages as indicated below.
2. New or changed material is indicated by a vertical bar in the margin of the pages.

Remove Pages

iii through viii  
1-1 and 1-2  
none  
4-45 and 446  
4-49 through 4-52  
none  
7-13 through 7-16  
9-13 and 9-14  
B-1 through B-3/(B4 blank)

Insert Pages

iii through viii  
1-1 and 1-2  
4-6.1 and 4-6 2  
4-45 through (4-46.5 blank)/4-46.6  
4-49 through 4-52  
4-59 through 4-64  
7-13 through 7-16  
9-13 and 9-14  
B-1 through B-3/(B-4 blank)

File this change sheet in the front of the publication for reference purposes.

Distribution Statement A: Approved for public release; distribution is unlimited

**By Order of the Secretary of the Army:**

**DENNIS J. REIMER**  
*General, United States Army*  
*Chief of Staff*

Official:



**JOEL B. HUDSON**  
*Administrative Assistant to the*  
*Secretary of the Army*  
0011805

DISTRIBUTION: To be distributed in accordance with the initial distribution requirements for IDN: 342407 for TM 9-254.

**CHANGE**

**No. 5**

**HEADQUARTERS  
DEPARTMENT OF THE ARMY  
Washington D.C., 1 February 1994**

**GENERAL MAINTENANCE PROCEDURES  
FOR  
FIRE CONTROL MATERIEL**

TM 9-254, dated 13 August 1984, is changed as follows:

1. The purpose of this change notice is to provide notification under Section 326 of Public Law 102-484, FY 93 National Defense Authorization Act, that Ozone Depleting Chemicals may no longer be used on Army equipment.

2. Throughout this publication the following items should be substituted for Ozone Depleting Chemicals used on your equipment:

FOR:

Trichloroethane  
6810-00-476-5613  
(81349) MIL-T-81533

SUBSTITUTE:

General purpose detergent  
7930-00-985-6911  
or  
Solvent, dry cleaning, SD2  
6850-00-274-5421  
P-D-680, type II

3. File this change notice in the front of the publication for reference purposes.

By Order of the Secretary of the Army:

**GORDON R. SULLIVAN**  
*General, United States Army*  
*Chief of Staff*

Official:

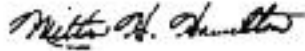

**MILTON H. HAMILTON**  
*Administrative Assistant to the*  
*Secretary of the Army*

05957

**DISTRIBUTION:** To be distributed in accordance with DA Form 12-34-E, Block 2407, requirements for TM 9-254.

CHANGE

No. 4

HEADQUARTERS  
DEPARTMENT OF THE ARMY  
Washington, DC 2 April 1993

**GENERAL MAINTENANCE PROCEDURES  
FOR  
FIRE CONTROL MATERIEL**

TM 9-254, 13 August 1984, is changed as follows:

1. Remove old pages and insert new pages as indicated below.
2. New or changed material is indicated by a vertical bar in the margin of the pages.

**Remove Pages**

vii and viii  
1-1 and 1-2  
4-35 and 4-36  
B-3/(B-4 blank)

**Insert Pages**

vii and viii  
1-1 thru 1-2.3/(1-2.4 blank)  
4-35 and 4-36  
B-3/(B-4 blank)

3. File this change sheet in the front of the publication for reference purposes.

By Order of the Secretary of the Army:

GORDON R. SULLIVAN  
General, United States Army  
Chief of Staff

Official:

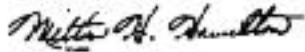

MILTON H. HAMILTON  
Administrative Assistant to the  
Secretary of the Army

03675

DISTRIBUTION:

To be distributed in accordance with DA Form 12-34-E, Block 2407, requirements for TM 9-254.



CHANGE

No. 3

HEADQUARTERS  
DEPARTMENT OF THE ARMY  
Washington, DC 13 August 1991

**GENERAL MAINTENANCE PROCEDURES  
FOR  
FIRE CONTROL MATERIEL**

TM 9-254, 13 August 1984, is changed as follows:

1. Remove old pages and insert new pages as indicated below.
2. New or changed material is indicated by a vertical bar in the margin of the pages.

**Remove Pages**

i and ii  
8-25/(8-26 blank)

**Insert Pages**

i and ii  
8-25 thru 8-30

3. File this change sheet in the front of the publication for reference purposes.

**By Order of the Secretary of the Army:**

**GORDON R. SULLIVAN**  
*General, United States Army*  
*Chief of Staff*

**Official:**

**PATRICIA P. HICKERSON**  
*Brigadier General, United States Army*  
*The Adjutant General*

**DISTRIBUTION:** To be distributed in accordance with DA Form 12-34E, (Block 2407), Requirements for TM 9-254.

CHANGE

No. 2

HEADQUARTERS  
DEPARTMENT OF THE ARMY  
Washington, DC 21 June 1988

**GENERAL MAINTENANCE PROCEDURES  
FOR  
FIRE CONTROL MATERIEL**

TM 9-254, 13 August 1984, is changed as follows:

1. Remove old pages and insert new pages as indicated below.
2. New of changed material is indicated by a vertical bar in the margin of the pages.

**Remove Pages**

v thru viii  
9-1 thru 9-12  
9-15 thru 9-30  
9-33 and 9-34  
10-1 thru 10-6  
B-1 and B-2  
D-1/(D-2 blank)

**Insert Pages**

v thru viii  
9-1 thru 9-12  
9-15 thru 9-30  
9-33 and 9-34  
10-1 thru 10-6  
B-1 and B-2  
D-1/(D-2 blank)

3. File this change sheet in the back of the publication for reference purposes.

**By Order of the Secretary of the Army:**

**CARL E. VUONO**  
*General, United States Army*  
*Chief of Staff*

**Official:**

**R. L. DILWORTH**  
*Brigadier General, United States Army*  
*The Adjutant General*

**DISTRIBUTION:**

To be distributed in accordance with DA Form 12-34C, requirements for Maintenance Expenditure Limits-AMCCOM.

CHANGE

No. 1

HEADQUARTERS  
DEPARTMENT OF THE ARMY  
Washington, DC 11 September 1985

**GENERAL MAINTENANCE PROCEDURES  
FOR  
FIRE CONTROL MATERIEL**

TM 9-254, 13 August 1984, is changed as follows:

1. Remove old pages and insert new pages as indicated below.
2. New or changed material is indicated by a vertical bar in the margin of the pages.

**Remove Pages**

1-1 and 1-2  
8-3 and 8-4

**Insert Pages**

1-1 and 1-2  
8-3 and 8-4

3. File this change sheet in the back of the publication for reference purposes.

**By Order of the Secretary of the Army:**

**JOHN A. WICKHAM, JR.**  
*General, United States Army*  
*Chief of Staff*

**Official:**

**DONALD J. DELANDRO**  
*Brigadier General, United States Army*  
*The Adjutant General*

**Distribution:**

**To be distributed in accordance with DA Form 12-34C, TB 43-Series: Equipment Improvement Report and Maintenance Digest-AMCCOM.**

TECHNICAL

HEADQUARTERS  
DEPARTMENT OF THE ARMY  
WASHINGTON, DC, 13 August 1984

NO. 9-254\*

GENERAL MAINTENANCE PROCEDURES

FOR

FIRE CONTROL MATERIEL

REPORTING ERRORS AND RECOMMENDING IMPROVEMENTS

You can help improve this manual. If you find any mistakes or if you know of a way to improve the procedures, please let us know. Mail your letter, DA Form 2028 (Recommended Changes to Publications and Blank Forms), or DA Form 2028-2 located in the back of this manual direct to: Director, Armament and Chemical Acquisition and Logistics Activity, ATTN: AMSTA-AC-NML, Rock Island, IL 61299-7630. A reply will be furnished to you.

		Page
	HOW TO USE THIS MANUAL.....	ix
	SAFETY SUMMARY .....	x
Chapter	1. INTRODUCTION	
Section	I. General Information.....	1-1
Section	II. Equipment Description and Data.....	1-1
Chapter	2. MAINTENANCE RECORDS AND SAFETY PROCEDURES	
Section	I. DA Maintenance Forms.....	2-1
Section	II. Safety and Emergency Procedures .....	2-2
Chapter	3. GENERAL MAINTENANCE PROCEDURES	
Section	I. Drilling and Reaming for Tapered Pins .....	3-1
Section	II. Staking, Peening, and Swaging.....	3-4
Section	III. Mechanical Assemblies .....	3-12
Section	IV. Tubular Level Assemblies.....	3-21
Section	V. Installation of Helical Inserts and Removal of Damaged Setscrews .....	3-26
Section	VI. Handling, Using, and Storing Expendables .....	3-31
Section	VII. Safe Storage of Loose Parts.....	3-42
Section	VIII. Use of Purging and Charging Equipment .....	3-43
Section	IX. Purging and Charging Fire Control Equipment .....	3-48
Chapter	4. HAND TOOLS	
Section	I. Use and Care of Hand Tools.....	4-1
Section	II. Measuring Techniques and Scribing.....	4-14
Section	III. Soldering and Desoldering Techniques .....	4-25
Section	IV. Use of Abrasives and Files .....	4-29

\*This manual supersedes TM 9-254, dated 8 December 1958

Distribution Statement A: Approved for public release, distribution is unlimited.

		Page
CHAPTER	5. <b>MEASUREMENT AND MECHANICAL DATA</b>	
Section	I. Measurement Data .....	5-1
Section	II. Temperature Data .....	5-14
Section	III. Angular Measurement Data .....	5-16
Section	IV. Mechanical Data .....	5-21
CHAPTER	6. <b>CABLES, HARNESSSES AND CONNECTORS</b>	
Section	I. Fabrication of Wiring Harnesses .....	6-1
Section	II. Cable Connectors .....	6-5
Section	III. Safety Wiring Techniques .....	6-16
Section	IV. Tagging Wires and Loose Parts During Disassembly .....	6-21
CHAPTER	7. <b>ELECTRONIC DATA</b>	
Section	I. Basic Laws and Formulas .....	7-1
Section	II. Electronic Component Identification .....	7-9
Section	III. Schematic Diagram Symbols .....	7-18
Section	IV. Troubleshooting techniques .....	7-22
CHAPTER	8. <b>ELECTRONIC TEST EQUIPMENT</b>	
Section	I. Meter Characteristics .....	8-1
Section	II. Oscilloscope Characteristics .....	8-11
Section	III. Power Supply Characteristics .....	8-23
CHAPTER	9. <b>OPTICAL DATA</b>	
Section	I. Definition of Common Optical Terms .....	9-1
Section	II. General Maintenance of Optical Components .....	9-13
Section	III. Reclamation of Optical Components .....	9-23
CHAPTER	10. <b>FIRE CONTROL TEST EQUIPMENT</b>	
Section	I. Optical Test Instruments .....	10-1
Section	II. Test Fixtures .....	10-4
APPENDIX	A. REFERENCES .....	A-1
APPENDIX	B. EXPENDABLE SUPPLIES AND MATERIALS LIST .....	B-1
APPENDIX	C. FABRICATED ITEMS .....	C-1
APPENDIX	D. LIST OF APPLICABLE PUBLICATIONS.....	D-1
ALPHABETICAL INDEX .....		Index 1



LIST OF ILLUSTRATIONS

Figure	Title	Page
3-1	Assortment of Tapered Pins .....	3-1
3-2	Selecting Drill for Tapered Hole.....	3-1
3-3	Installing a Tapered Pin In a Wormshaft Assembly.....	3-3
3-4	Staking Threaded Parts.....	3-5
3-5	Staking Headed Screws .....	3-5
3-6	Staking Flathead Screw.....	3-6
3-7	Staking Screws with Sealing Compound.....	3-7
3-8	Staking Reticle and Retainer Ring.....	3-8
3-9	Peening Tools .....	3-8
3-10	Peening a Rivet .....	3-9
3-11	Swage Blocks Prepared for Use.....	3-10
3-12	Swaging .....	3-11
3-13	Cross-Sectional View of Swage Blocks in Use.....	3-11
3-14	Worm and Worm Gear Mechanism Using the Worm Ball Cap.....	3-12
3-15	Typical Worm and Worm Gear Mechanism.....	3-13
3-16	Point of Relief for Plunger.....	3-15
3-17	Plunger Sticking or Weak Spring .....	3-16
3-18	Shaft Rubbing on Housing.....	3-16
3-19	Handwheel Rubbing on Housing.....	3-17
3-20	Worm Bottoming in Worm Gear .....	3-17
3-21	End Play in Wormshaft.....	3-18
3-22	Dog-Point Screw Tight Against Socket .....	3-19
3-23	Dog-Point Screw Loose In Housing.....	3-20
3-24	Level Vial with Two Piece Eccentric .....	3-23
3-25	Level Vial with Three Piece Eccentric.....	3-24
3-26	Helical Inserting Tool.....	3-27
3-27	Installing Helical Insert .....	3-27
3-28	Removing Insert Tang.....	3-28
3-29	Extracting Insert.....	3-28
3-30	Using Spiral Tapered Screw Extractor.....	3-30
3-31	Slotting Damaged Setscrew.....	3-30
3-32	Removing Old Gasket Material .....	3-31
3-33	Applying Adhesives.....	3-32
3-34	Moisture and Fungus Proofing an Electronic Circuit Board.....	3-33
3-35	Hand Oiler.....	3-34
3-36	Applying Grease to Bearing .....	3-35
3-37	Applying Grease to Beaded Seal .....	3-36
3-38	Removing Sealing Compound from a Setscrew.....	3-37
3-39	Mixing Two Part Curing Type Sealing Compound.....	3-38
3-40	Applying Sealing Compound to a Setscrew.....	3-39
3-41	Sealing Internal Groove.....	3-39
3-42	Applying Insulating Compound on a Transistor .....	3-40
3-43	Use of Heat Shrinkable Sleeving.....	3-41
3-44	Storage Containers for Loose Parts .....	3-42
3-45	Single Stage Pressure Test Fixture .....	3-44
3-46	Two Station Pressure Test Fixture .....	3-46
3-47	Purging and Charging M I 18 Series Elbow Telescope.....	3-49
3-48	Pressurizing Level Assembly .....	3-51
3-49	Leak Testing Level Assembly .....	3-52
3-50	Leak Testing Cover Assembly .....	3-54

LIST OF ILLUSTRATIONS - Continued

Figure	Title	Page
4-1	Torque Computation .....	4-1
4-2	Length Vs Force - Torque.....	4-2
4-3	Torque Wrench - Hand Position .....	4-3
4-4	Torque Wrench - Illustrated Use .....	4-3
4-5	Torque Wrench - Straight Extension.....	4-4
4-6	Torque Wrench - Angled Extension.....	4-5
4-7	Micrometer Caliper - Cutaway View.....	4-7
4-8	Micrometer Barrel .....	4-8
4-9	Graduated End of Thimble .....	4-8
4-10	Micrometer Barrel Setting - .300 inch .....	4-9
4-11	Micrometer Barrel Setting - .172 inch.....	4-10
4-12	Micrometer Barrel Setting - .362 inch .....	4-10
4-13	Micrometer Barrel Setting - .504 inch .....	4-11
4-14	Thickness Gage - Blade Type.....	4-11
4-15	Traverse Lock Assembly .....	4-12
4-16	Thickness Gage .....	4-13
4-17	Types of Steel Rules .....	4-14
4-18	Determining Proper Graduated Rule .....	4-15
4-19	Measuring Technique .....	4-16
4-20	Types of Machinist's Scribes .....	4-24
4-21	Using the Scriber .....	4-25
4-22	Electric Soldering Station.....	4-26
4-23	Electric Soldering Station - Exploded View .....	4-27
4-24	Position of Tip for Maximum Heat Transfer.....	4-29
4-25	Applying Solder .....	4-30
4-26	Bellows Assembly 10512969 - Exploded View .....	4-31
4-27	Soldering Shaft Collar to Shaft .....	4-32
4-28	Soldering Bellows to Shaft Collar .....	4-33
4-29	Soldering Sleeve Bushing to Bellows .....	4-34
4-30	Wicking Procedures .....	4-36
4-31	Thermal Stripper .....	4-37
4-32	Mechanical Wire Strippers.....	4-38
4-33	Using a Heat Shunt .....	4-39
4-34	Wire Tinning .....	4-39
4-35	Tinned Wires - Examples.....	4-40
4-36	Printed Circuit Board Holder .....	4-41
4-37	Crossing Conductive Lines .....	4-42
4-38	Minimum Pigtail Bend.....	4-42
4-39	Direction of Pigtail Clinch .....	4-43
4-40	Welded Lead with Proper Bend .....	4-43
4-41	Flush Mounting - Examples .....	4-44
4-42	Terminal Before Swaging .....	4-44
4-43	Terminal After Swaging.....	4-45
4-44	Soldering Swaged Terminal .....	4-45
4-44.1	Typical Panel Mounted IC .....	4-46
4-44.2	DIP Mounting and Soldering.....	4-46.1
4-44.3	Typical Flat Pack Positioning and Installation.....	4-46.1
4-44.4	Repair Sequence Flow Chart .....	4-46.2

## LIST OF ILLUSTRATIONS - Continued

Figure	Title	Page
4-44.5	Foil Repair.....	4-46.3
4-44.6	Damaged Conductor (Trace) Repair.....	4-46.4
4-44.7	Flexible Circuit.....	4-46.4
4-45	Resistance Soldering Unit.....	4-47
4-46	Resistance Soldering a Cup Terminal.....	4-48
4-47	Lapping on a Surface Plate.....	4-52
4-48	Normal Filing Procedure.....	4-53
4-49	Using a Flat File.....	4-54
4-50	Using a Round File.....	4-55
4-51	Removing Burrs from a Flat Surface.....	4-55
4-52	Grinding Window Chips.....	4-56
4-53	Thread Chasers.....	4-57
4-54	Using Thread Chasers.....	4-58
4-55	Hand Tap Details.....	4-60
5-1	Artillery Mil to Degree Conversion Chart.....	5-18
5-2	Angular Displacement.....	5-21
5-3	Typical Screw Thread Form.....	5-22
6-1	Typical Wiring Harness Diagram.....	6-1
6-2	Typical Pin Board Diagram.....	6-2
6-3	Lacing Starting Stitch.....	6-3
6-4	Running Lock Stitch.....	6-3
6-5	Finishing Square Knot.....	6-4
6-6	Clove Hitch Spot Tie.....	6-4
6-7	Types of Cable Connectors.....	6-5
6-8	Female Single Lead Connector.....	6-6
6-9	Male Single Lead Connector.....	6-7
6-10	Straight Plug Connector.....	6-8
6-11	Insulated Solderless Connector.....	6-9
6-12	Uninsulated Solderless Connector.....	6-9
6-13	Crimping a Solderless Connector.....	6-10
6-14	Crimping Requirements for Solderless Connectors.....	6-11
6-15	Removal of Front Release Connector Contact.....	6-11
6-16	Installation of Front Release Connector Contact.....	6-12
6-17	Termi-Twist Contact Removal - Preparation.....	6-13
6-18	Termi-Twist Contact Removal.....	6-14
6-19	Termi-Twist Contact Installation.....	6-14
6-20	Termi-Twist Contact Bottoming.....	6-15
6-21	Termi-Twist Contact Locking.....	6-15
6-22	Safety Wire Applications.....	6-17
6-23	Safety Wire Installation.....	6-19
6-24	Safety Wire Installation - Multiconnection.....	6-20
6-25	Item Identification Tags.....	6-21
7-1	Ohm's Law for DC Circuits.....	7-1
7-2	Series Circuit.....	7-2
7-3	Parallel Circuit.....	7-3
7-4	AC Sine Wave.....	7-4
7-5	Ohm's Law for AC Circuits.....	7-4
7-6	Capacitance Formulas.....	7-6
7-7	Inductance Formulas.....	7-7

## LIST OF ILLUSTRATIONS - Continued

Figure	Title	Page
7-8	Instantaneous Values of AC.....	7-8
7-9	Color Code Markings for Military Standard Resistors .....	7-9
7-10	Typical Carbon Resistor Wattage Reference Chart .....	7-10
7-11	Capacitor Identification.....	7-11
7-12	RF Inductor Identification.....	7-13
7-13	Typical Diode Shapes and Markings .....	7-14
7-14	Diode Schematic Symbol.....	7-14
7-15	N-P-N and P-N-P Transistors.....	7-15
7-16	Transistor Packaging.....	7-15
7-16.1	Component Installation.....	7-16
7-17	Fuse Marking Example.....	7-17
7-18	Electronic Component Schematic Symbols.....	7-18
7-19	Logic Gate Symbols.....	7-21
7-20	How to Troubleshoot - Diagram.....	7-23
7-21	Eight Stage Block Diagram .....	7-24
8-1	Proper Voltmeter Connection.....	8-3
8-2	Proper Current Meter Connection.....	8-3
8-3	Proper Ohmmeter Connection .....	8-4
8-4	Transistor Shown As a Two-Diode Element .....	8-6
8-5	Simpson 260 Series - Multimeter.....	8-9
8-6	Multimeter Face .....	8-10
8-7	Oscilloscope Subassemblies .....	8-12
8-8	Front Panel Controls .....	8-13
8-9	Vertical Amplifier Controls .....	8-14
8-10	Main Triggering Amplifier.....	8-16
8-11	Time/Div or Dly Time Control .....	8-17
8-12	Volts/Div Control .....	8-18
8-13	Square Waveform Display .....	8-19
8-14	Calibrated Signal Display.....	8-20
8-15	Oscilloscope Probes .....	8-22
8-16	Probe Adjustment and Waveforms .....	8-23
8-17	DC Power Supply .....	8-24
9-1	Deviation of Light Rays Through a Convergent Lens .....	9-2
9-2	Deviation of Light Rays Through a Diverging Lens .....	9-2
9-3	Newtons Rings .....	9-3
9-4	Parallax Shield .....	9-3
9-5	Reflection From a Plain Mirror.....	9-4
9-6	Effects of Refraction.....	9-4
9-7	Diaphragm (Stop) Location in an Optical System .....	9-5
9-8	Types of Filter Mountings .....	9-6
9-9	Principles of Light Polarization .....	9-7
9-10	Amici Prism.....	9-7
9-11	Dove Rotating Prism .....	9-8
9-12	Porro Prism Erecting System.....	9-8
9-13	Penta Prism.....	9-9
9-14	Pechan Prism .....	9-9
9-15	Right Angle Prism Showing Deflection of Light Rays .....	9-10
9-16	Light Deviations Through an Optical Wedge .....	9-10
9-17	Using Mirrors to Simulate a Penta Prism.....	9-11
9-18	Reticle Patterns Superimposed on Field of View .....	9-12
9-19	Types of Reticles used in Fire Control Instruments .....	9-12

## LIST OF ILLUSTRATIONS - Continued

Figure	Title	Page
9-20	Vacuum Suction Adapter.....	9-15
9-21	Wood or Fiberglass Applicator for Lens Tissue - Example.....	9-15
9-22	Path of Applicator When Cleaning a lens .....	9-16
9-23	Straight and 90 Degree Vacuum Tips - Example .....	9-16
9-24	Suction Cup Adapter. ....	9-17
9-25	Lens Marking System.....	9-18
9-26	Marking a Single Prism.....	9-19
9-27	Marking Prism Pairs .....	9-19
9-28	Proper Method of Holding a Lens .....	9-26
9-29	Holding Fixture .....	9-27
9-30	Optical Coating Unit .....	9-29
9-31	Optical Coating Unit - With Holding Fixture Installed.....	9-31
10-1	Projector Collimator.....	10-1
10-2	Projector Collimator Reticle .....	10-2
10-3	Collimating Telescope .....	10-3
10-4	Dioptometer.....	10-3
10-5	Azimuth Test Fixture .....	10-5
10-6	Telescope Test Fixture.....	10-6
10-7	Adapters for Telescope Test Fixture.....	10-6
10-8	Equipment for Telescope Test Fixture .....	10-7
10-9	Cross Leveling Fixture .....	10-8
10-10	Universal Vibration Tester .....	10-9
10-11	Lens Bench .....	10-10
C-1	Leak Test Adapter.....	C-1
C-2	One Piece Eccentric Tool .....	C-3
C-3	Two Piece Eccentric Tool .....	C-4

## LIST OF TABLES

Table	Title	Page
2-1	Vehicle.....	2-2
2-2	Electrical Systems and Subsystems.....	2-3
3-1	Tapered Pins and Drill Sizes.....	3-2
4-1	Torque Unit Conversion.....	4-6
4-1.1	Torque Value Guide - Pound Feet.....	4-6.1
4-1.2	Torque Value Guide - Newton Meters.....	4-6.2
4-2	Conversion - Millimeters to Inches.....	4-18
4-3	Conversion - Fraction of an Inch to Decimals of an Inch and Millimeters.....	4-49
4-4	Conversion - Decimals of an Inch to Millimeters.....	4-20
4-5	Conversion - Inches to Millimeters.....	4-21
4-6	Conversion - Feet to Meters.....	4-22
4-7	Conversion - Meters to Feet.....	4-23
4-8	Proper Wire Selection.....	4-46.2
4-9	Standard Drill Sizes.....	4-59
4-10	Thread Limits, Type I, Series A Through C, Cut Thread Taps.....	4-62
4-11	Thread Limits, Type II, Series D Through G.....	4-64
5-1	Metric Prefixes.....	5-1
5-2	Weights and Measures - U.S. System.....	5-2
5-3	Weights and Measures - Metric System.....	5-2
5-4	U.S. System to Metric System Conversion.....	5-3
5-5	Conversion Factors.....	5-4
5-6	Temperature Conversion.....	5-15
5-7	Formulas for Temperature Conversion.....	5-16
5-8	Artillery Mils to Degrees.....	5-19
5-9	Degrees to Artillery Mils.....	5-20
5-10	Basic Coarse Thread Dimensions and Tap Drill Sizes - American Machine Screw.....	5-22
5-11	Basic Coarse Thread Dimensions and Tap Drill Sizes.....	5-24
5-12	Annealed Copper Wire Data.....	5-26
6-1	Termi-Twist Contact Tools.....	6-13
6-2	Safetywire.....	6-18
7-1	DC Relationships.....	7-2
7-2	AC Relationships.....	7-5
7-3	Instantaneous Values of AC.....	7-8
7-4	Fuse Style.....	7-16
7-5	Fuse Voltage Ratings.....	7-16
7-6	Fuse Current Ratings.....	7-17
7-7	Fuse Characteristics.....	7-17
8-1	Low Power P-N-P Transistor Characteristics.....	8-7
8-2	Low Power N-P-N Transistor Characteristics.....	8-7
8-3	Medium Power P-N-P Transistor Characteristics.....	8-7
8-4	Medium Power N-P-N Transistor Characteristics.....	8-7
8-5	High Power P-N-P Transistor Characteristics.....	8-8
8-6	High Power N-P-N Transistor Characteristics.....	8-8
9-1	Special Tools and Supplies.....	9-14
9-2	Prisms and Mirrors.....	9-22
9-3	Field Lenses.....	9-22
9-4	Eye Lenses.....	9-22
9-5	Objective, Erector Lenses, and Windows.....	9-23
9-6	Reticles.....	9-23
C-1	Fabricated Tools and Adapter.....	C-1

## HOW TO USE THIS MANUAL

### MANUAL CONTENTS

This manual consists of general maintenance procedures which are common to two or more items of fire control materiel. Maintenance procedures that are specific in nature pertaining to one particular item will be found in the maintenance manual pertinent to that item.

This manual also contains information covering general maintenance procedures for electronic equipment, mechanical equipment, and optical equipment. The procedures include information such as instructions for cleaning, lubricating, painting, and sealing.

### INFORMATION LOCATION

To find information quickly:

1. The front cover index is keyed to black boxes at the edge of the pages.
2. A more detailed table of contents is on page i.
3. Items blocked in table of contents appear on front cover index.
4. An appendix of current references, including but not limited to technical manuals is on page A-1.
5. An alphabetical index is on page Index 1.

## **SAFETY SUMMARY**

The following are general safety precautions not related to any specific procedures and do not appear elsewhere in this publication. These are recommended precautions that personnel must understand and apply during many phases of operation and maintenance.

### **TEST PROCEDURES**

Personnel must follow the procedures precisely and place special attention to cautions and warnings.

### **HAZARDOUS SOLVENTS**

When using solvents, insure the area is well ventilated. Use gloves and eye protection. Flammable solvents must be kept away from heat, sparks, and open flames. Flush contaminated eyes and skin with water for 15 minutes.

### **JOB PERFORMANCE**

Never work on electronic equipment unless personnel, familiar with operation and hazards of equipment and competent in administering first aid, are nearby. When a technician is aided by operators, the technician must warn operators of dangerous areas.

Whenever the nature of the operation permits, keep one hand away from the equipment to reduce the hazard of current flowing through the body. In order to prevent back injuries when lifting heavy equipment, always have someone else present to help lift.



## CHAPTER 1

### INTRODUCTION

---

#### Section I. GENERAL INFORMATION

##### 1-1. Scope.

The purpose of this manual is to provide general fire control procedures, tables, and applicable data that other publications do not necessarily cover in detail. It is intended as a guide to assist maintenance personnel in performance of their duties. If specific instructions are provided in a technical publication pertaining to a specific fire control item, this manual does not attempt to take precedence over that publication. This publication, however, may be used as a reference document for maintenance procedures in conjunction with the various technical manuals that address specific fire control equipment.

##### 1-2. Maintenance Forms, Records, and Reports.

Department of the Army forms and procedures used for equipment maintenance will be those prescribed by DA PAM 738750, as contained in Maintenance Management Update, The Army Maintenance Management System (TAMMS).

##### 1-3. Reporting Equipment Improvement Recommendations (EIR).

If the equipment used in this manual needs improvement, let us know. Send us an EIR. You, the user, are the only one who can tell us what you don't like about your equipment. Let us know why you don't like about your equipment. Let us know why you don't like the design. Put it on an SF 368 (Quality Deficiency Report) Mail it to us at: Commander, U.S. Army Armament, Research, Development and Engineering Center, ATTN: AMSTA-AR-QAW-A (R) /Customer Feedback Center, Rock Island, IL 61299-7300. We'll send you a reply.

#### Section II. EQUIPMENT DESCRIPTION AND DATA

##### 1-4. Equipment Characteristics, Capabilities, and Features.

Equipment used in this manual varies in use and in scope from electronic test equipment to mechanical and optical equipment. The operation and use of the equipment in this manual is presented as a guide to assist maintenance personnel in the performance of their duties.

##### 1-5. Safety, Care, and Handling.

The following safety precautions are listed for the protection of personnel performing maintenance procedures contained in this manual.

a. Compressed Gas. Compressed nitrogen gas is used for purging and charging of equipment. Death or severe injury may result if personnel fail to observe safety precautions. High pressure tanks can explode and kill people. Handle tanks very carefully.

b. Toxic Vapors. Various solvents and compounds which produce toxic vapors are used throughout this manual. Do not use toxic vapor producing agents in a confined area. Avoid long periods of breathing toxic vapors and avoid contact with skin.

## 1-5. Safety, Care, and Handling - Continued

c. First Aid. Prior to performing any work requirements, the personnel should be familiar with the first aid information contained in FM 21-11 (TEST).

d. Radioactive Material.



- (1) Rules and Regulations. Copies of the following rules and regulations maintained at HQ, AMCCOM, Rock Island, IL 61-6000. Copies may be requested or information obtained by contacting the AMCCOM radiological Protection Officer (RPO), AUTOVON 793-2964/2965, Commercial (309) 782-2964/2965.
- (a) 10CFR Part 19 - Notices, Instructions and Reports to Workers; Inspections.
  - (b) 10CFR Part 20 - Standards for Protection Against Radiation.
  - (c) 10CFR Part 21 - Reporting of Defects and Noncompliance.
  - (d) NRC license, license conditions, and license application.
- (2) Safety Precautions. The radioactive material used in fire control instruments is tritium gas (H3) sealed in Pyrex tubes. It poses no significant hazard to the repairer when intact. These sources illuminate the instrumentation for night operations. Tampering with or removal of the sources in the field is prohibited by Federal Law. In the event there is no illumination, notify the local Radiological Protection Officer. Do not attempt to repair or replace the instrument in the field. If skin contact is made with any area contaminated with tritium, wash immediately with nonabrasive soap and water.
- (3) Identification. Radioactive self-luminous sources are identified by means of radioactive warning labels (as above). These labels should not be defaced or removed and should be replaced immediately when necessary. Refer to the local RPO or the AMCCOM RPO for instructions on handling, storage, or disposal.
- (4) Storage and Shipping. All radioactively illuminated instruments or modules which are defective will be evacuated to a depot maintenance activity. These items must be placed in a plastic bag and packaged in the shipping container from which the replacement was taken before evacuation to a higher echelon is made. Spare equipment must be stored in the shipping container as received until installed on the weapon. Storage of these items is recommended to be in an outdoor shed type storage or unoccupied building.

a. Personnel handling the device should wear rubber or latex gloves. Device must be immediately double wrapped in plastic, sealed, packaged and evacuated to depot. Outside package must be identified as "Broken Tritium Device - Do Not Open". Dispose of used gloves as radioactive waste, per instructions from local RPO and wash hands well.

b. Personnel who may have handled the broken tritium device should report to health clinic for tritium bioassay. Optimum bioassay sample is at least four hours after exposure.

c. Broken tritium sources indoors may result in tritium contamination in the area, such as a work bench or table. The area must be cordoned off, restricted until wipe tests indicate no contamination.

6. Training: Installations that use, maintain or store tritium devices must appoint a Radiation Protection Officer (RPO). The RPO must have at least 8 hours training specifically in handling tritium devices and emergency procedures. Personnel who use tritium devices must receive one hour basic radiation safety training and General Support (GS) personnel in tritium device repair facilities will have at least four hours training in hazards of tritium, handling tritium devices and emergency procedures.

7. Maintenance: Tritium device repair facilities must have local standard operating procedures (SOPs) that incorporate the following safety procedures:

a. General Support (GS) personnel who work in the area will have a baseline bioassay as a minimum.

b. GS maintenance will store spare tritium parts in separate, non-occupied and well-ventilated storage area.

c. Porous work benches (e.g., wood) on which tritium devices are repaired will be covered with Kraft paper to prevent build up of tritium contamination. Replace paper at least once a quarter.

d. Wipe tests will be taken of general support maintenance facilities at least quarterly with records kept of analysis.

e. Removal of the radioluminous source or maintenance on a non-illuminated device is prohibited except at authorized depots.

f. "No eating, drinking, smoking or applying cosmetics" signs will be posted in tritium device work areas.

8. Identification: Radioactive self-luminous sources are identified by means of radioactive warning labels (as above). These labels should not be defaced or removed, and should be replaced immediately when necessary.

9. Posting notices: The Nuclear Regulatory Commission Form NRC-3 "Notice to Employees," will be posted at the main entrance to areas where radioactive materials or other sources of radiation are used, stored, and repaired. Copies of Form NRC-3 are available from the local RPO.

**Change 4 1-2.1**

10. Posting documents: The following NRC documents will be posted with Form NRC-3. If this is not practical, a notice may be posted along with Form NRC-3 describing each document and where it may be examined. Copies of documents a, b, and c, are available from the licensee listed in paragraph 11.b. below.

- a. Title 10 CFR, Part 19 - Notices, Instructions and Reports to Workers; Inspections.
- b. Title 10 CFR, Part 20 - Standards for Protection Against Radiation.
- c. NRC license, license conditions, and license application.
- d. Local Standard Operating Procedures (SOPs).

11. Further information:

a. If assistance is needed, contact your local or major command (MACOM) safety office(s) for further information on safe handling, shipping, storage, maintenance, or disposal of radioactive devices.

b. The licensee/AMCCOM RPO may be contacted by writing to Commander, U.S. Army Armament, Munitions and Chemical Command (AMCCOM), ATTN: AMSMC-SFS, Rock Island, IL 61299-6000, or telephone: DSN 793-2965/2995, Commercial (309) 782-2965/2995, Fax extension 2289, E-Mail SF01@RIAEMH1.ARMY.MIL. After work hours the AMCCOM RPO may be contacted through the staff duty office at DSN 793-6001, Commercial (309) 782-6001.

c. An example of equipment containing tritium is the M1A1 Collimator in the following illustration.

**Change 4 1-2.2**

M1A1 Infinity Collimator, Infinity Aiming Reference

The M1A1 Collimator is the primary aiming reference point for indirect laying operations. It is usually stored in its storage case. The reticle pattern, which is radioactively illuminated, is wipe tested.

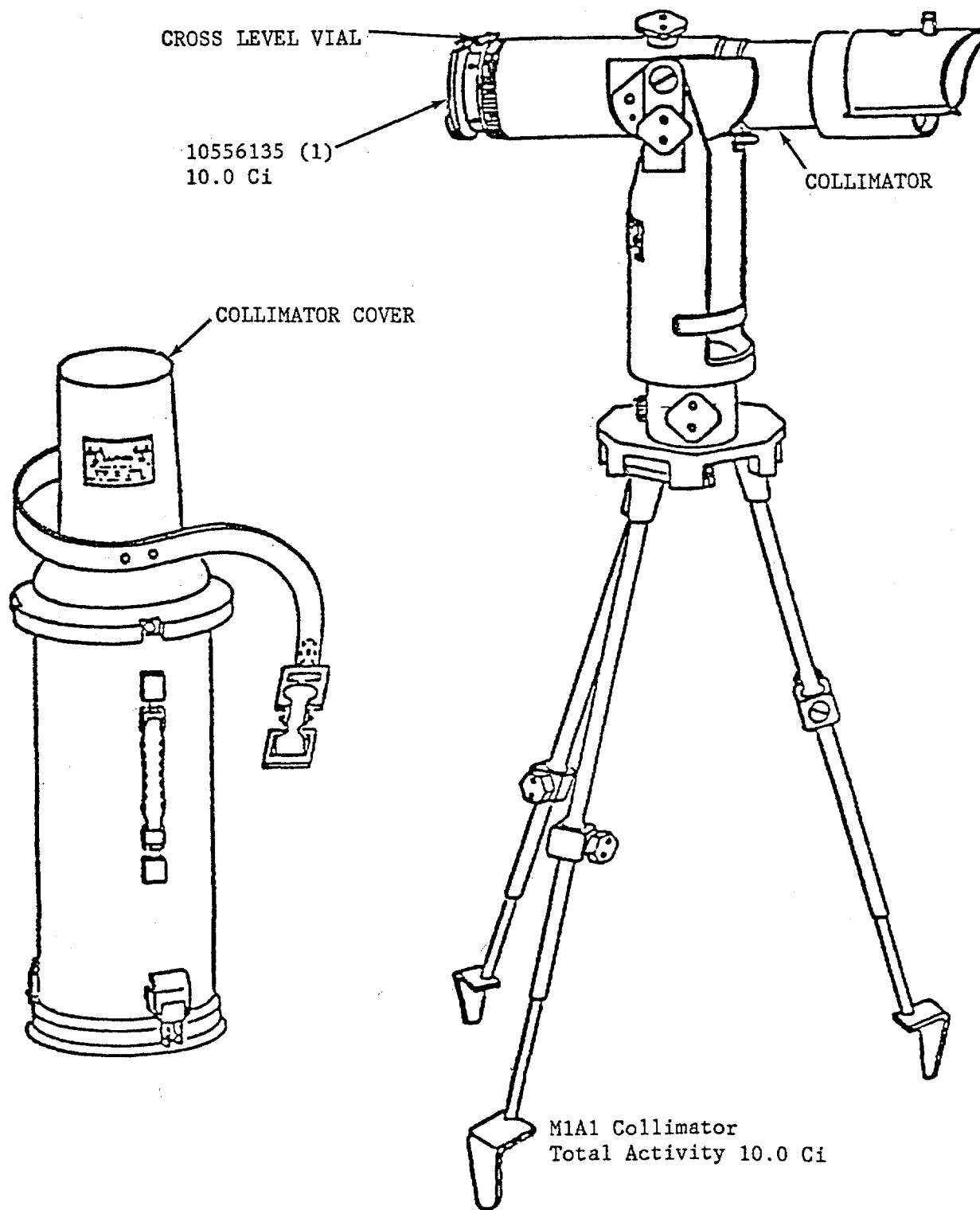

Change 4 1-2.3/(1-2.4 blank)

## CHAPTER 2

MAINTENANCE RECORDS AND SAFETY PROCEDURES

---

## Section I. DA MAINTENANCE FORMS

**2-1. General.**

DA PAM 738-750, The Army Maintenance Management Systems (TAMMS), provides the guidelines for selecting and completing the required DA maintenance forms.

**2-2. Types of Maintenance Forms.**

a. There are five types of maintenance forms available for use.

- (1) Operational Records
- (2) Maintenance Records
- (3) Equipment Historical Records
- (4) Ammunitions Records
- (5) Calibration Records

b. The most frequently used of the five types of forms, for fire control items, are addressed here. This section provides the following information for each of the forms assigned:

- (1) Use
- (2) Preparation

c. The most frequently used forms for maintenance of fire control items are as follows:

- (1) DD Form 1574 - Serviceable Tag, Condition Code A.
  - (a) Use. Use this tag on material or items that are serviceable (issuable w/o qualification, issuable with qualification, or priority issue).
  - (b) Preparation. Enter federal stock number, part number, item description, serial number (as applicable), program control number (PCN), quantity, and condition code. Affix tag to item.
- (2) DD Form 1577 - Unserviceable (Condemned) Tag, Condition Code H.
  - (a) Use. Use this tag on material or items that are unserviceable (condemned).
  - (b) Preparation. Enter federal stock number, part number, item description, serial number (as applicable), program control number (PCN), quantity, and condition code. Affix tag to item.

**2-2. Types of Maintenance Forms - Continued**

(3) DD Form 1577-2 - Unserviceable (Repairable) Tag, Condition Code F.

(a) Use. Use this tag on material or items that are unserviceable (limited restoration, or incomplete).

(b) Preparation. Enter federal stock number, part number, item description, serial number (as applicable), program control number (PCN), quantity, and condition code. Affix tag to item.

**Section II. SAFETY AND EMERGENCY PROCEDURES**

**2-3. Field Report of Accidents.**

Whenever there is an injury to personnel or damage to materiel, make out the required reports following the directions in AR 385-40 and DA PAM 738-750.

**2-4. General Safety Items and Actions.**

a. First Aid. Serious injury may occur at any time during maintenance procedures. Prior to performing any maintenance procedures, personnel should be familiar with the first aid information contained in FM 21-11 (TEST).

b. Safety Items and Actions. The following tables contain safety items pertaining to personnel and equipment.

*Table 2-1. Vehicle*

<b>Safety item</b>	<b>Hazard</b>	<b>Required action</b>
Traversing	Being struck by traversing turret.	Be sure all personnel are clear of hull when traversing turret, and that area is clear of all objects.
Traversing cupola	Being struck by loader's hatch cover.	Be sure loader's hatch cover is in the fully open or closed position and turret area clear.
Grills, access doors and covers	Being caught in rotating mechanisms.	Be sure all grills, access doors, and covers are closed or latched in the open position.

## 2-4. General Safety Items and Actions - Continued

Table 2-2. Electrical Systems and Subsystems

Safety item	Hazard	Required action
Number of personnel needed to work on high voltage units.	Electrical shock/burns.	Always have at least two persons present when working on high voltage aid or summon help units; one to give first in case of accident.
Working on equipment in inclement weather.	Making electrical adjustments in rain or snow with power applied.	Protect yourself and equipment by tarpaulin. Dry equipment with hot air dryer before making adjustments.
Unqualified personnel working on equipment.	Personnel injury/equipment damage.	Only qualified personnel are permitted to make adjustments or modifications to electrical components.
Electrical work on wet surfaces.	Electrical shock/burns.	Under certain conditions, even low voltages can be dangerous to life. Make sure you always follow the same safety rules used for high voltages.
Attaching to ground	Electrical shock/burns.	Before attaching any ground, always make the ground end of the connection first. When removing grounds, disconnect ground end of connection last.
Unknown wires	Electrical shock/burns.	Treat every wire as energized.



2-4. General Safety Items and Actions - Continued

Table 2-2. Electrical Systems and Subsystems - Continued

Safety item	Hazard	Required action
Use of improper tools.	Personnel injury/equipment damage.	Use only the proper tools for the job. Make sure pliers and other electrical handtools are properly insulated.
Improper type fire extinguisher for electrical fire.	Electrical shock/equipment damage.	Keep CO <sub>2</sub> or dry chemical (Class C or D) type fire extinguisher handy. Regularly check to insure that extinguisher is pressurized.
Improper type storage or handling of combustible materials.	Personnel injury/ equipment and facilities.	Do not use gasoline or other explosive items near spark producing equipment.
Energized circuits.	Personnel injury/damage to equipment.	Make all connections to de-energized conductors. Do not energize circuits until after the last connection is made.

**CHAPTER 3**  
**GENERAL MAINTENANCE PROCEDURES**

**Section I. DRILLING AND REAMING FOR TAPERED PINS**

**3-1. Tapered Pins and Tapered Holes.**

a. General. A tapered pin (fig. 3-1) may be defined as a metal rod with a diameter that decreases uniformly. Tapered pins are used to secure one part to another in a positive relation to each other, such as the securing of a knob to a shaft.

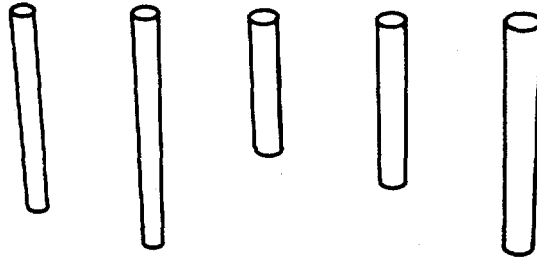

*Figure 3-1. Assortment of Tapered Pins*

b. Numbering System. All tapered pins are tapered similarly (1/4 in. per ft.) and certain diameters are identified with numbers. All pins with the same number would then have the same maximum diameter; therefore, the longer the pin (of any one number), the smaller the minimum diameter.

c. Preparation of Parts to Receive Tapered Pin. When preparing parts to receive a tapered pin, a hole must be drilled and then reamed with a tapered reamer. The larger the drill used, within the scope of the taper, the less reaming will be required. Before drilling any hole for a tapered pin, it is necessary to know the minimum diameter of the pin to be used so that a drill may be selected accordingly. Refer to figure 3-2 and table 3-1 for selecting the proper drill size required for a tapered hole. When the proper drill size has been determined, the hole should be drilled and then reamed with a tapered reamer of the correct number.

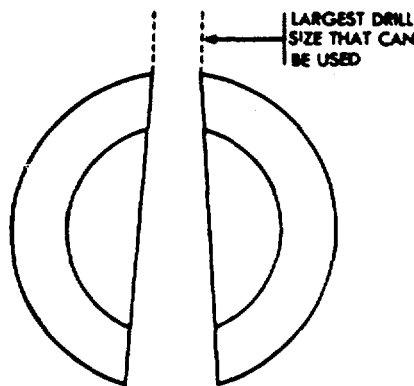

*Figure 3-2. Selection Drill for Tapered hole*

## 3-1. Tapered Pins and Tapered Holes - Continued

Table 3-1. Tapered Pins and Drill Sizes

Length of pin (in.)	Reamer and pin number										
	6/0	5/0	4/0	3/0	2/0	0	1	2	3	4	5
3/8	50	44	38	32	29						
1/2	51	45	39	33	30	27					
5/8	52	46	41	34	30	27	21				
3/4	1/16	47	42	7/64	1/8	9/64	5/32	16	13/64	15/64	1
1		49	44	37	31	29	25	11/64	9	1	H
1-1/4					32	30	26	19	10	2	G
1-1/2						1/8	9/64	20	3/16	7/32	F
1-3/4						31	29	5/32	14	3	E
2						33	30	25	16	4	D
2-1/4						7/64	1/8	26	11/64	13/64	C
2-1/2						37	31	28	19	8	B
2-3/4						40	33	29	21	11	1
3						42	35	30	5/32	3/16	2
3-1/4									24	14	2
3/1-2									26	16	3
3-3/4										17	4
4										19	5

d. Precautions Before Installing Pin. Before securing two parts with a tapered pin, always check the direction of the taper. Slip the pin loosely in the hole from either side. It should be driven into the side in which it enters most deeply. When securing two parts which have been previously drilled and reamed for a tapered pin, such as a wormshaft and knob, check the direction of the taper in both parts and assemble accordingly. The parts should have been marked during disassembly to insure that they are assembled in the same position. Failure to follow the practice of checking the direction of taper in the parts may cause damage to the parts when the pin is driven in and possibly make the instrument unserviceable.

### 3-1. Tapered Pins and Tapered Holes - Continued

e. Installation of Tapered Pin (fig. 3-3). To install a tapered pin, first be sure that the hole is properly lined up as outlined in paragraph d above. A clean hole and a well machined pin should fit together within one-sixteenth of an inch of the final position. If this is not true, check the pin for burrs and the hole for poor alignment of parts. Support work with a V-block and position tapered pin into knob of worm shaft assembly. Place the flat tip of a drive pin punch over the exposed end of the tapered pin. Give one sharp tap on the end of the drive pin punch with a hammer to set the tapered pin. Check to insure that the tapered pin has seated properly and the knob is securely fastened to shaft. If tapered pin protrudes through the hole, file off excess pin until it is flush with the surface.

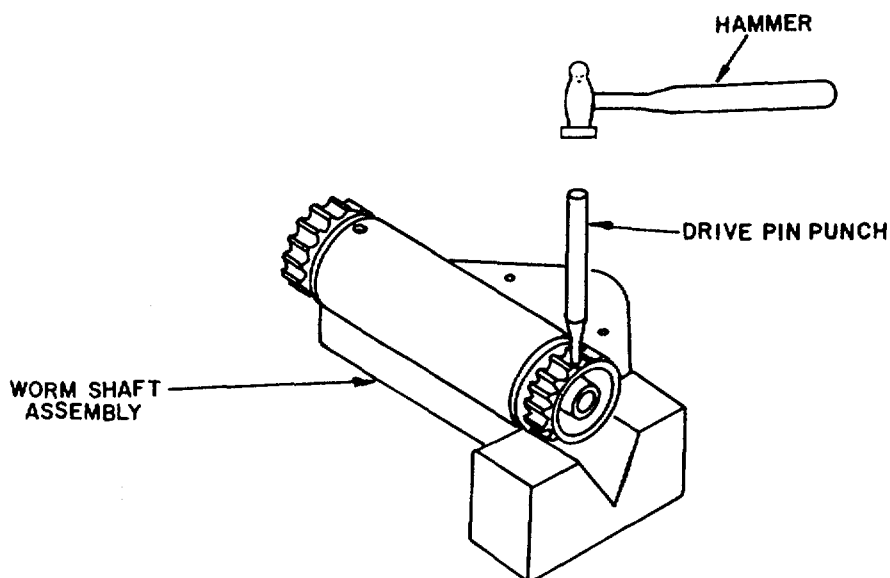

Figure 3-3. Installing a Tapered Pin In a Wormshaft Assembly

f. Removal of Tapered Pin (fig. 3-3). To remove a tapered pin, look to determine which is the smaller of the two ends. Support the work on a V-block with smallest end facing up. Select a drive pin punch slightly smaller in diameter than the small end of the pin. Place the flat tip of a drive pin punch against the small end of the pin and strike the punch one sharp blow using a hammer. Such a blow will usually remove the pin, whereas several haphazardly struck blows will damage the end of the pin. Determine the size of the hammer according to the size of the job.

### 3-2. Reconditioning Damaged Tapered Holes.

When the tapered hole has become damaged because of reasons previously outlined, the hole must be reconditioned before a pin can be installed. The reconditioned hole and the new pin will, in most cases, be one size larger because of the material removed from the hole. As in the case of a new hole, the repair will involve drilling and reaming. Line up the tapers of both parts and secure the assembly on the drill press with the hole perpendicular to the drill press table. Select the proper size drill that will be necessary to provide a hole of the next larger size. Check the drill for centering in the hole and drill. Ream out the hole with the proper size tapered reamer. Check to see how far the pin drops into the hole, then touch up the hole with the reamer until the pin seats properly. If tapered pin protrudes through the hole, file off excess pin until it is flush with the surface.

## Section II. STAKING, PEENING, AND SWAGING

### 3-3. General.

Reshaping (not removal) of metal is done by staking, peening, or swaging. These terms are defined in (1) through (3) below.

- (1) Staking is a method of securing parts by pushing surface metal together with punch and hammer.
- (2) Peening is the stretching of surface metal, usually with a ball peen hammer or with a hammer and a specially designed round-nose chisel.
- (3) Swaging is the moving of metal throughout its entire thickness where a definite shape is desired.

### 3-4. Staking.

a. General. Staking is a process usually employed to secure two parts together. It is not to be confused with waterproofing of screwheads. Threaded parts that draw up to a certain critical point are sometimes staked to maintain that position. The advantage of staking is that it holds parts together in a final position.

#### **CAUTION**

**Staking with a punch and hammer may be difficult for the inexperienced repairer. A great deal of damage may be done to the material being staked, such as bent tubular parts, if the procedure is not followed with extreme skill and care.**

b. Staking Threaded Parts (fig. 3-4). A recommended procedure for staking threaded parts is as follows:

#### **NOTE**

**This procedure does not apply to optical components.**

- (1) Be sure that the desired adjustment of the nut (1) on shaft (2) is correct.
- (2) Place center punch (3) at right angle to the nut surface and close to the shaft (2) but not so close that punch will hit the shaft.
- (3) With a ball peen hammer, give the punch (3) a solid tap and then remove the punch.
- (4) Examine staking hole. If metal has moved enough to pinch threaded parts together, move on to next staking position.
- (5) If metal has not moved enough, move punch closer to the shaft (2). You may need to tilt the punch (4) less than 90 degrees.
- (6) Stake at least two places (5), approximately 180 degrees apart. The size and the number of staking holes will depend on the type of metal and size of parts to be staked.

3-4. Staking - Continued

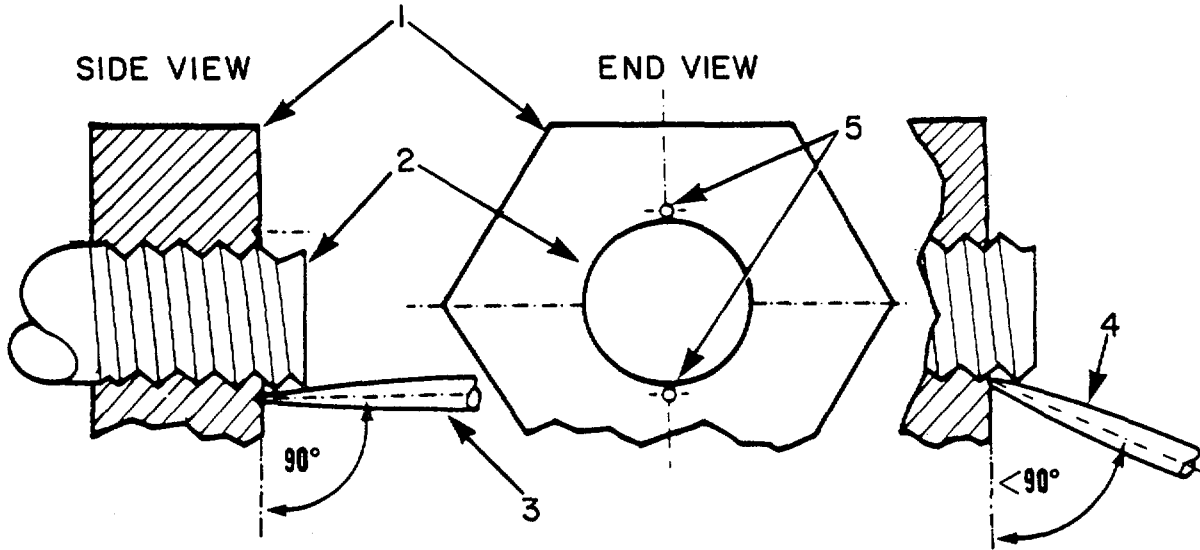

Figure 3-4. Staking Threaded Parts

c. Staking Headed Screws (fig. 3-5). A recommended procedure for staking headed screws is as follows:

- (1) Be sure that screw (2) is in proper position and tightened.
- (2) Place center punch (3) on screw (2), but not so close to the edge that it will break through the metal of the screw.
- (3) With a medium weight ball peen hammer, give the punch (3) a solid tap.
- (4) Examine staking hole (1). If the metal has moved enough to lock screw (2), go on to next staking position.
- (5) If metal has not moved enough, move center punch closer to the edge of the set screwhead, and tap with hammer.
- (6) Stake second hole in the same manner and check the screw (2) to see that it is locked in place.

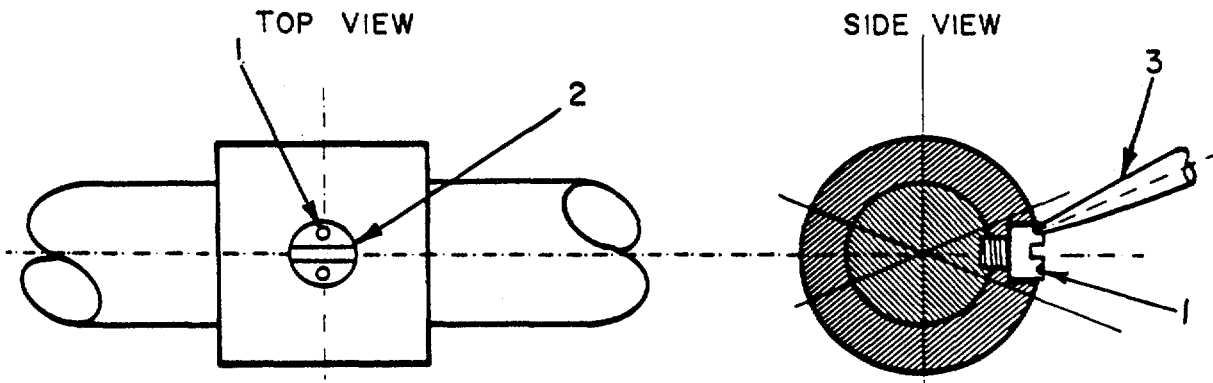

Figure 3-5. Staking Headed Screws

### 3-4. Staking - Continued

- d. Staking Flathead Screw (fig. 3-6). A recommended procedure for staking a flathead screw is as follows:
- (1) Be sure that the flathead screw (2) is in the proper position and tightened.
  - (2) Place center punch (3) on the flathead screw (2) near the edge.
  - (3) With a medium weight ball peen hammer, give the punch (3) a solid tap.
  - (4) Examine staking hole (1). If the metal has moved enough to lock the flathead screw (2), go on to the next staking position.
  - (5) If metal has not moved enough, move center punch closer to the edge of the flathead screw and tap with hammer.
  - (6) Stake second hole approximately 180 degrees from first hole (1) in the same manner. Check the flathead screw (2) to see that it is locked in place.

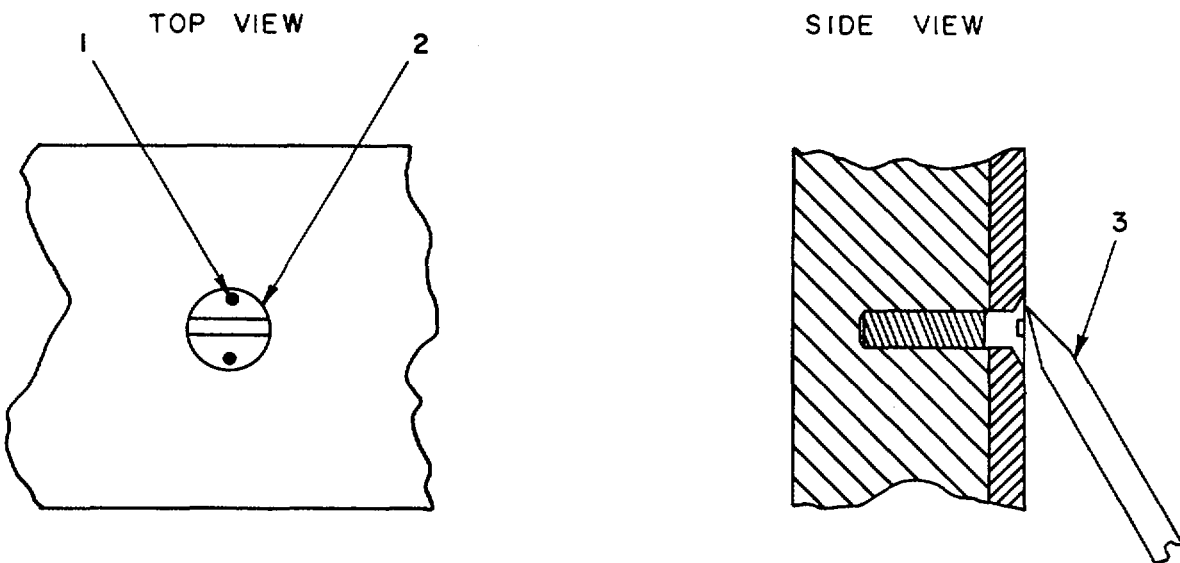

Figure 3-6. Staking Flathead Screw

- e. Staking with Sealing Compound (fig. 3-7). Another method of staking would be the use of sealing compound instead of a punch and hammer. An example of this procedure would be the staking of the six cap screws (1) in the eyepiece and erector lens subassembly of the M118 series Elbow Telescopes. In this example, the normal procedure would be:

### 3-4. Staking - Continued

- (1) Insure that the six cap screws (1) are properly positioned and secured in place.
- (2) Use the handle of a disposable (2) swab or similar device to apply a spot of sealing compound to the mating surfaces of the cell housing and cap screw (1).
- (3) Repeat the staking process described in step (2) above for the five remaining cap screws (1).

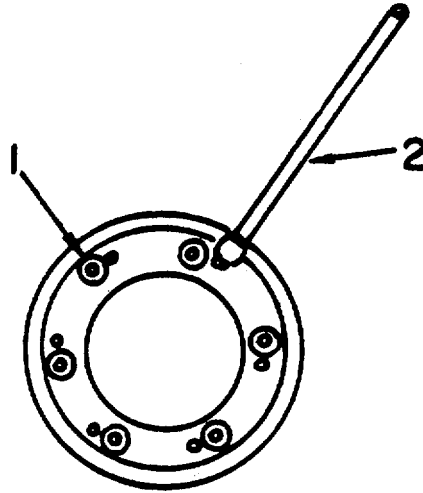

Figure 3-7. Staking Screws with Sealing Compound

f. Staking Reticle and Retaining Ring with Sealing Compound (fig. 3-8). A recommended procedure for staking a reticle and retaining ring is as follows:

- (1) Be sure that the reticle (2) is positioned properly in the cell (1) and secured by retainer ring (4).
- (2) Use the handle of a disposable swab (3) or similar device to apply a spot of sealing compound to the three slots (6) on the cell (1).
- (3) Turn the cell assembly over and apply a spot of sealing compound to the two slots (5) of the retainer ring (4).



3-4. Staking - Continued

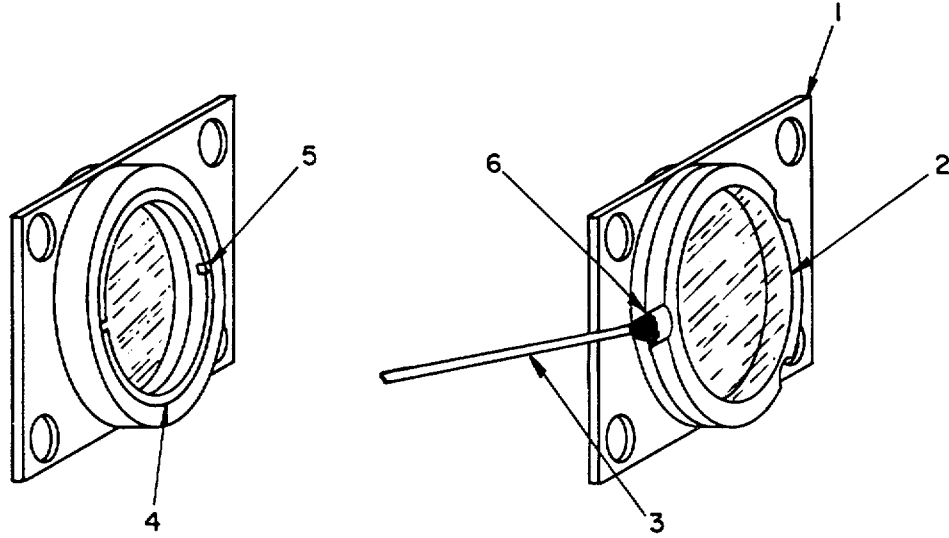

Figure 3-8. Staking Reticle and Retainer Ring

3-5. Peening.

a. General. Peening is a method used to move or stretch the surface metal of the work in a definite direction. Probably the best example is the simple riveting-over of a bolt to keep the nut from unscrewing. The tools necessary to do a peening job will vary somewhat according to the size and accessibility of the work. The ball, cross, or straight peen hammer (fig. 3-9) is all that is necessary to do a job of peening. The roundness of the working edges or faces of these tools make indentations in the work rather than cuts, thereby moving the metal without destroying it.



Figure 3-9. Peening Tools

### 3-5. Peening - Continued

b. Preparation for Peening. Most of the preparation for a peening job consists of an analysis of where to do the striking. The spherical indentations caused by the use of a ball peen hammer cause the metal to spread. Thus, the selection of the proper tool is an important factor in preparation. The part to be peened must always be backed up with the proper tool or holding device

c. Procedure. For example, suppose that the handle of a carrying case has become loose. It is decided to tighten this handle by peening the rivets which secure it to the case. Figure 3-10 illustrates the use of an anvil placed on the under side of the handle to back up the rivets, and the blows being struck on a rivet with the peen of the hammer. The blows must be so directed as to cause the metal of the rivet to flow, tightening the assembly, the blows should be light and the metal must flow slowly and smoothly.

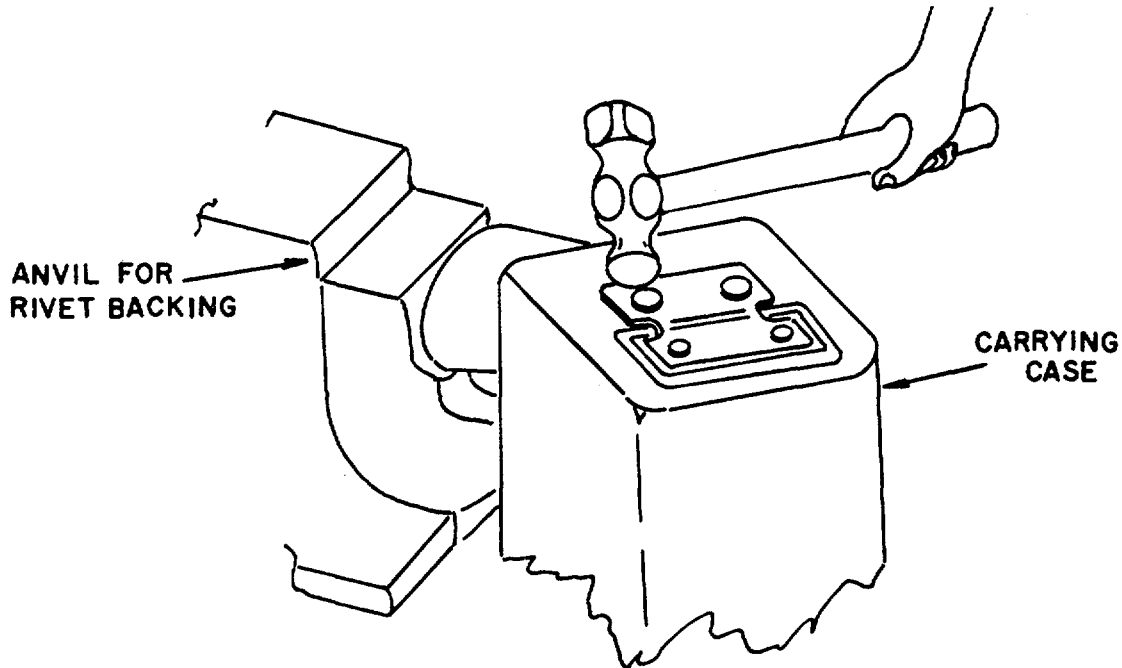

Figure 3-10. Peening a Rivet

### 3-6. Swaging.

a. General. Swaging is a process used to move metal when a series of hammer blows (peening) is difficult to control or where a smooth resulting surface is required. Swaging is performed by successive blows on dies, called swage blocks, which are shaped in such a manner as to give a required form. For instance, if a flat square form is desired, the swage blocks would be two pieces of flat stock. Curved forms will require curved blocks

b. Preparation for Swaging. Much of the preparation is in the analysis of the job, as in peening. The principal question is where to exert the force to do the most good. Selecting the swage blocks is also primarily important. In some cases these blocks will require machining to accurately meet a required dimension.

3-6. Swaging - Continued

c. Example of Typical Swaging Job. For example, suppose that, in the aiming circle M1, the bearing surface for the right trunnion of the telescope has become worn, resulting in a loose fit. To overcome this condition, a pair of swage blocks must be made which will assist in reducing the size of the hole. The analysis of this particular condition is illustrated in figures 3-11, 3-12, and 3-13. The important feature of these swage blocks is the diameter of the pilot on the lower block that must fit the bearing surface. It must be of exactly the same diameter as the right trunnion of the telescope. As the blows are struck on the blocks, turn the body of the aiming circle around at different points so that an even pressure on the metal will be obtained. This particular job will not require many blows since the material is brass and very thin. If the material was heavier and difficulty was encountered in reducing the size of the hole, the upper block could have a raised portion, as illustrated in figure 3-13. The raised portion tends to localize the blows and increase the flow of the metal. A block of this type may be used only when the surface contacted does not have to be flat.

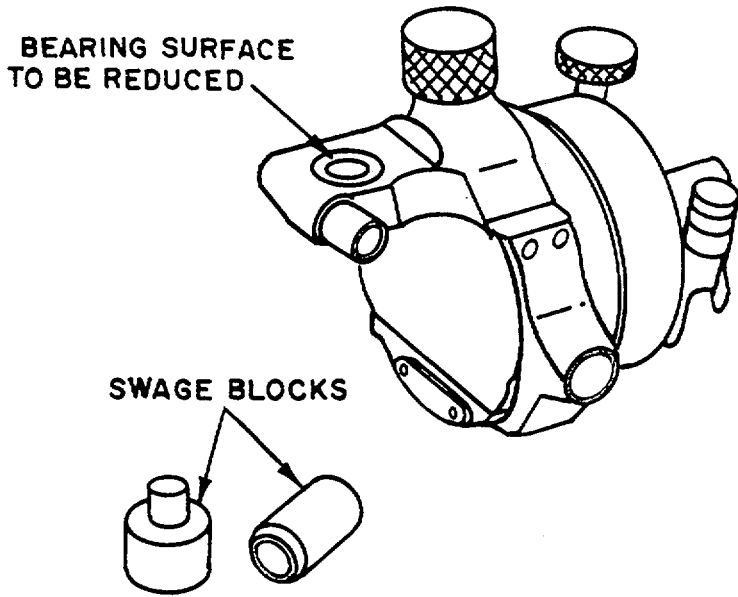

Figure 3-11. Swage Blocks Prepared for Use

d. Precautions. When properly practiced, swaging will move the metal throughout its entire thickness. If the blows are struck lightly, only the surface of the metal will move and the piece will soon return to its undesired shape. Therefore, make sure that the metal is moved throughout its entire thickness. After the blocks have been used, they should be cleaned, a light coat of oil applied to them, and then they should be stored in a dry place.

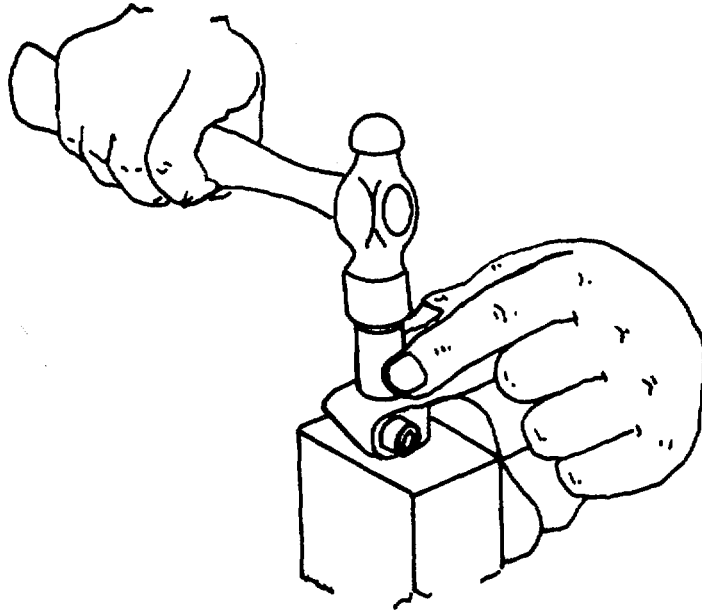

Figure 3-12. Swaging

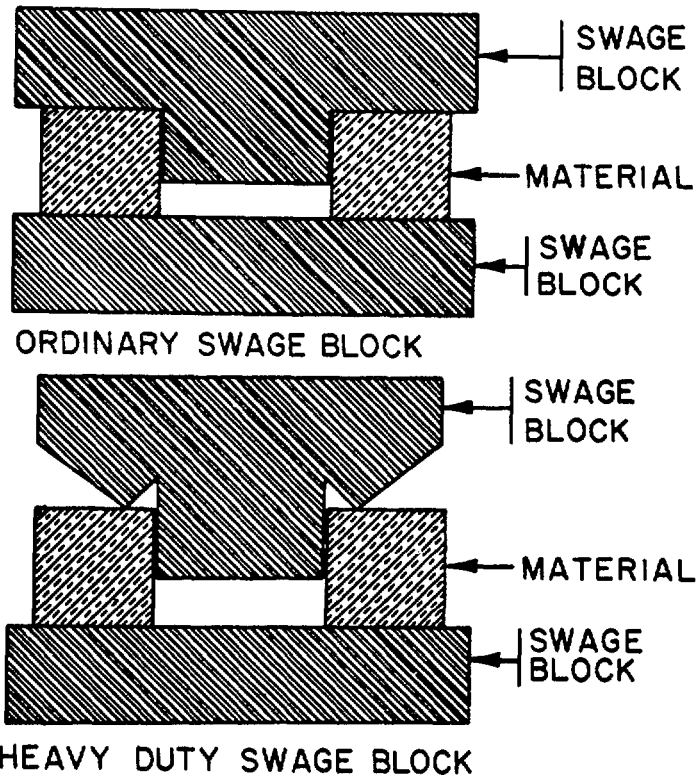

Figure 3-13. Cross-Sectional View of Swage Blocks in Use

## 3-6. Swaging - Continued

## Section III. MECHANICAL ASSEMBLIES

## 3-7. Worm and Worm Gear Mechanisms.

a. General. The worm and worm gear principle is widely used in fire control instruments as a means of rotating an instrument in azimuth and in elevation. This principle has been adopted as the standard for mechanical movements in almost all rotating instruments.

- (1) Figure 3-14 illustrates a worm and worm gear mechanism using a worm ball cap, which is threaded for adjustment to prevent lateral movement of the worm. The worm is held in mesh by a spring and plunger arrangement on the end.

**CAUTION**

Worm ball caps presently in use in some instruments, are made of brass, phenolic (plastic), or nylon. Any attempt to lap ball caps made of phenolic, or nylon will damage these items.

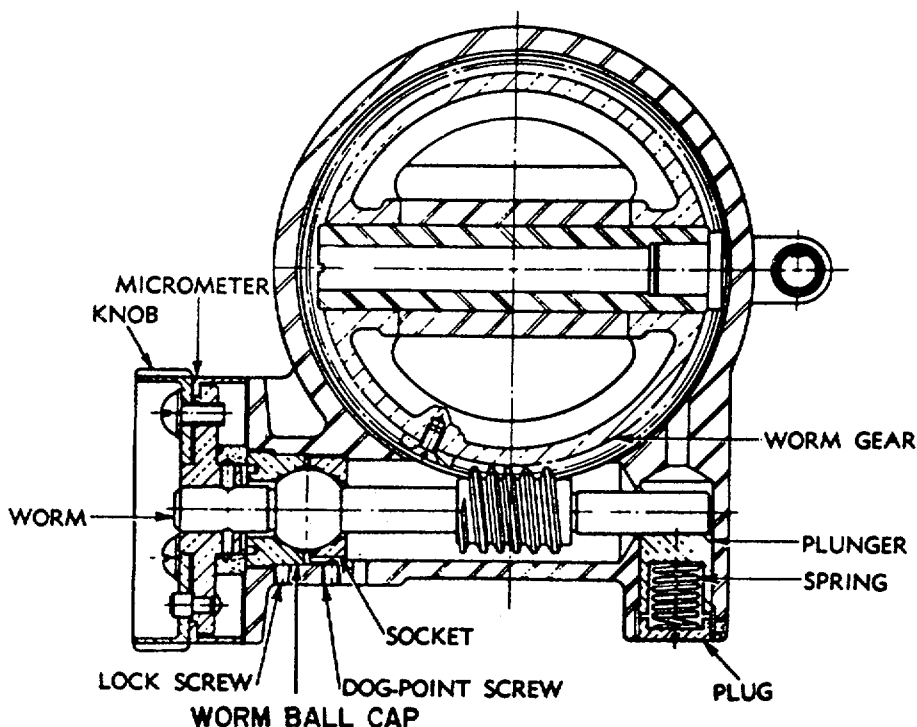
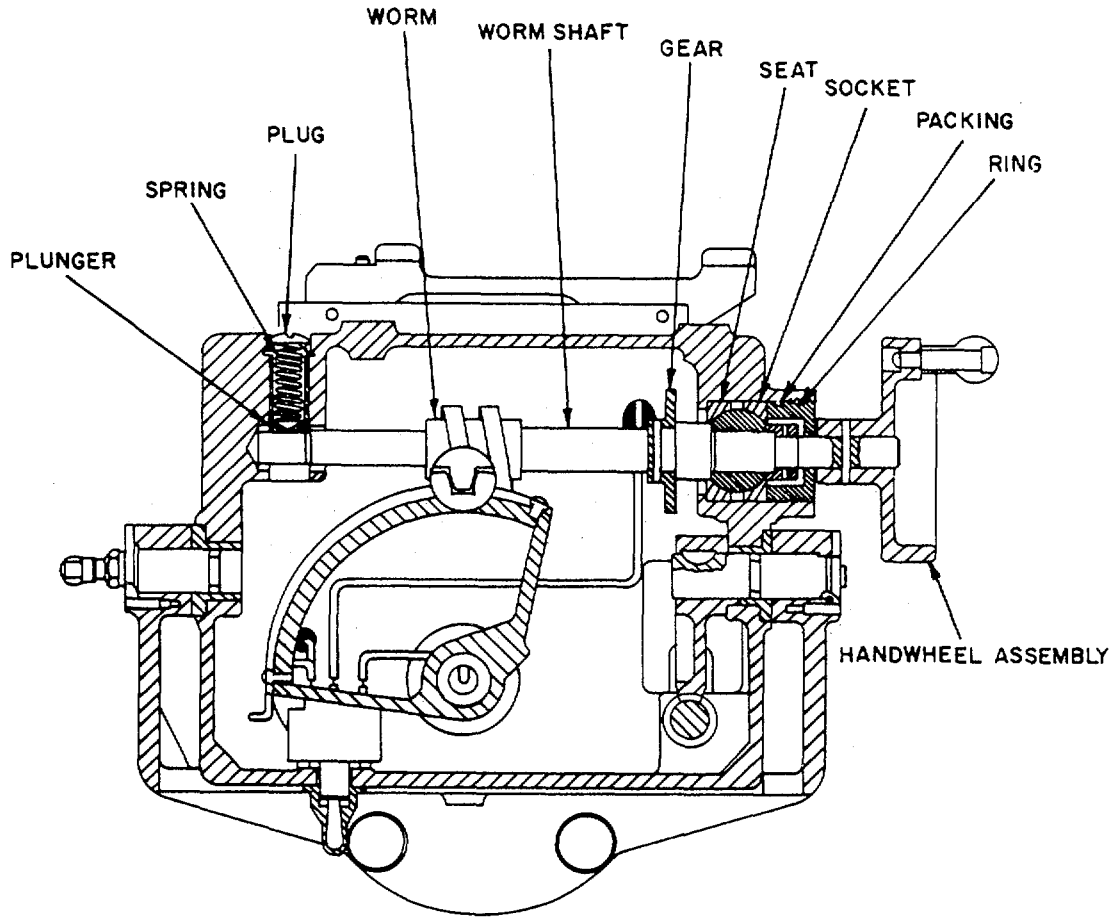

Figure 3-14. Worm and Worm Gear Mechanism Using the Worm Ball Cap

- (2) Figure 3-15 illustrates a typical worm and worm gear mechanism using a seat, socket, and threaded ring to prevent lateral movement of the worm. The thread ring is used for adjustment and the worm is held in mesh by a spring and plunger arrangement on the one end. Before proceeding with any maintenance work in connection with this type of mechanism, all maintenance work for the wormshaft, as outlined in b below, must be thoroughly understood.

**3-7. Worm and Worm Gear Mechanisms - Continued**

b. Maintenance of Wormshaft. For a wormshaft to operate properly, the shaft itself must be absolutely true and straight, to prevent the worm from being thrown off center at each revolution of the shaft and causing a binding movement in the worm and worm gear mechanism. If such binding occurs, it is frequently due to a bend or, more often, several bends in the shaft. In such cases, the entire wormshaft should be replaced. It may sometimes be necessary to locate and straighten these bends. This process involves much skill and the ability to select from a wide variety of methods best suited to the particular condition found. No specific procedure can be outlined. Generally, the entire length of the shaft must be continually tested during the straightening process and the shaft must be straightened to a point where the worm thread will be no more than 0.001 inch off center when the shaft is rotated in its bearings. Care must be taken to avoid damaging the worm thread or any of the bearing surfaces while straightening the wormshaft.



*Figure 3-15. Typical Worm and Worm Gear Mechanism*

c. Maintenance of Wormshaft Ball. The wormshaft ball plays an important part in obtaining a smooth nonbinding movement free from backlash therefore, the ball must be perfectly round. An out-of-round ball provides a poor bearing surface and will cause binding in the throwout mechanism, as well as being a source of backlash trouble.

**3-7. Worm and Worm Gear Mechanisms - Continued**

d. Fitting Plunger to Housing. The plunger must fit in the housing without any side play. If it fits loosely, the wormshaft will have side play which will appear as backlash on the micrometer dial. In order to facilitate handling of a new plunger when fitting, select a piece of brass or steel rod, a little larger in diameter than the spring hole in the plunger, and turn a slight taper on the end of it. Then force the plunger tightly on the rod. The rod must not turn within the plunger. Lap the plunger in the housing so that the plunger will be free enough to move smoothly up and down when a slight finger pressure is exerted against it.

e. Lapping Worm and Worm Gear Mechanism.

- (1) Before lapping is started, always clean the parts thoroughly and examine the teeth for nicks, burrs, and sharp edges. If a new worm is to be installed, place the worm in a lathe chuck and with the lathe running at slow speed, file a slight radius on the corners of the worm thread. Whether a new or old worm is used it is always best to check the gear mesh before lapping is started. Wipe a fine coat of Prussian blue on the worm thread and assemble the instrument. Turn the worm over the entire range of movement and then disassemble. Check for high spots and bottoming. Scrape off the high spots. If an old worm is bottoming in the worm gear, set the worm up in a lathe and turn off about 0.010 inch for the outside diameter of the worm thread. Check to insure that the worm is not bottoming on the worm gear.
- (2) If a new worm bottoms in the worm gear, then the worm gear teeth are worn excessively and a new worm gear should be installed. When the bearing of a new worm in an old worm gear is checked, it may be found that the new worm is riding on the corners of the worm thread, because the old worm had a larger radius on the corners. Do not increase the radius on the new worm. Examine the corners of the worm gear teeth. If there is a visible ridge, scrape it off with a three-cornered scraper.
- (3) The wormshaft must fit in the semicircular bearing surface of the plunger without any side play. If side play is present, this will appear on the handwheel as backlash. Before lapping in, relieve the center portion of the semicircular bearing as shown in figure 3-16. This is done so that the wormshaft will wear itself in deeper, reducing the possibility of developing side play.
- (4) Apply a thin coat of fine lapping compound to the worm, gear, seat, socket, and plunger's bearing surface. Mount the wormshaft mechanism in the housing and adjust ring so that there will be no end play in the shaft. When lapping worm and worm gear mechanism, better results will be obtained by removing the spring behind the plunger and installing a solid plug. In this manner, any minute high spot which might be rolled over will be removed, increasing the perfection of the fit. Lap in by turning the wormshaft a few times in each direction. Remove wormshaft mechanism from housing and inspect mating surfaces between shaft and plunger; between worm and gear; between seat, ball, and socket. The lapping process is complete when fine abrasive marks appear across the entire mating surfaces of the items being lapped together.

### 3-7. Worm and Worm Gear Mechanism - Continued

- (5) After lapping has been completed, remove the worm gear mechanism from the housing. Thoroughly wash all parts in cleaning solvent to remove the lapping compound. Place the wormshaft in a lathe and increase the radius on the corners of the worm thread. This is done to allow the worm to move into proper mesh as the movement wears.

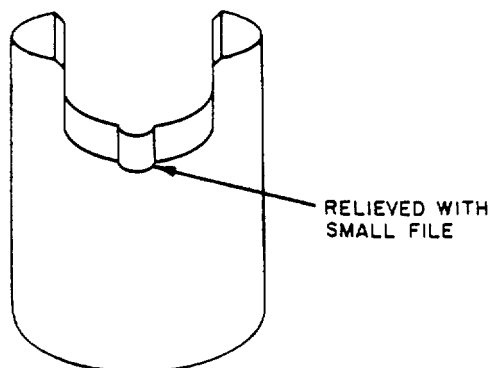

Figure 3-16. Point of Relief for Plunger

#### f. Backlash.

- (1) Backlash is one of the main factors contributing to the malfunctioning of the moving mechanical parts in fire control instruments. It is free play or movement of the driving member without corresponding movement of the driven member. The total absence of backlash is the ideal condition for fire control instruments. It is well known, however, that small amounts of backlash must be present in order to obtain smoothly functioning and operable mechanical movements. Tolerance limits for backlash have, therefore, been established for the various instruments. These limits can be found in the pertinent technical manuals and rebuild standards. There are many causes for backlash. The most prevalent are looseness in gear meshes, end play in shafts, side play in bearings, and binding in bearing surfaces. In many cases it will be found that total backlash is a result of a combination of these causes.
- (2) The inspection for backlash in fire control instruments is primarily a means for determining the angular distance through which the driving member (worm) of a mechanism moves before causing movement of the driven member (worm gear). The types of mechanisms usually encountered are azimuth mechanisms, elevation mechanisms, angle-of-site mechanisms, and cross-leveling mechanisms.
- (3) Looseness in gear meshes is a type of backlash due to the slack or looseness between the mating members of a mechanism. To use the example of the worm and worm gear, a close mesh of the worm with the teeth of the worm gear is obtained by means of pressure against the wormshaft from a spring and plunger (fig. 3-15). If the teeth are not firmly in mesh, there may be rotation of the worm without a corresponding movement of the worm gear. This condition may be due to a weak plunger spring which does not force the worm all the way in or which permits it to ride out instead of turning the worm gear (fig. 3-17).



3-7. Worm and Worm Gear Mechanisms - Continued

It may be due to burrs or irregularities on the plunger or its housing which do not permit the plunger to bear firmly on the wormshaft . It may be due to the fact that the worm and worm gear are so badly worn that the wormshaft bears on its housing and the worm is prevented from meshing fully with the worm gear (fig. 3-18). It may also be due to improper clearance between the micrometer or handwheel and the housing (fig. 3-19). The lost motion, or slack, may also result from bottoming which prevents full mesh of the teeth. Bottoming is the condition which exists when the crests of the teeth of one member bear in the troughs of the other (fig. 3-20).

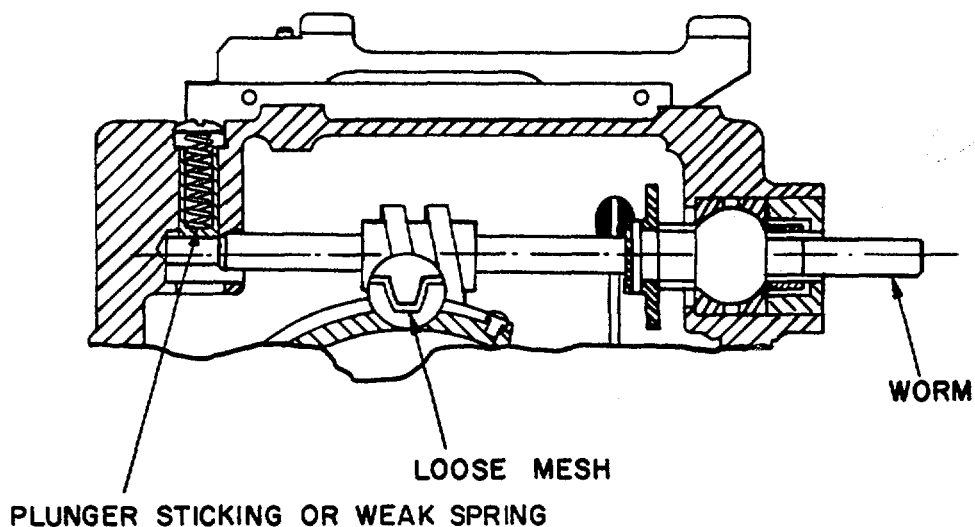

Figure 3-17. Plunger Sticking or Weak Spring

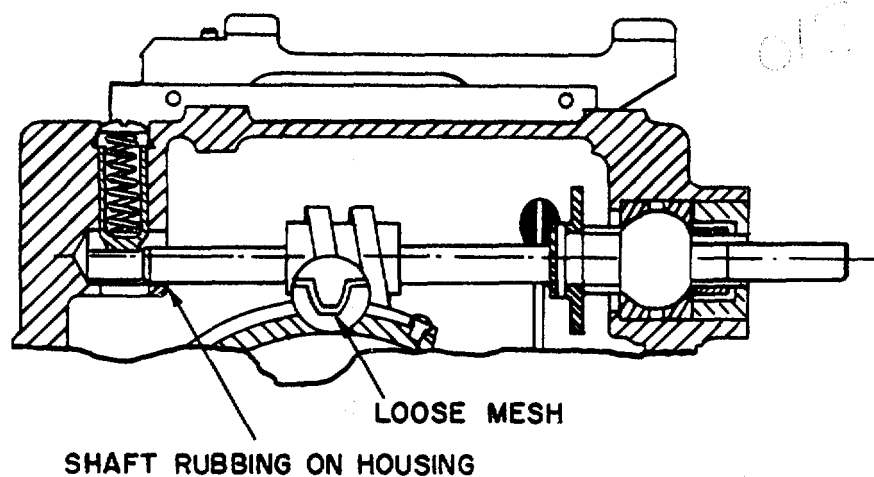

Figure 3-18. Shaft Rubbing on Housing

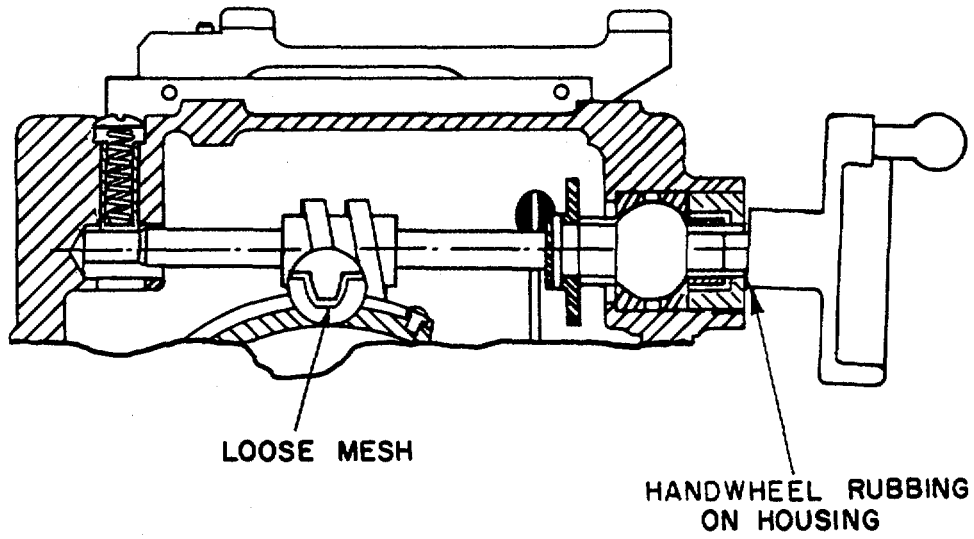

Figure 3-19. Handwheel Rubbing on Housing

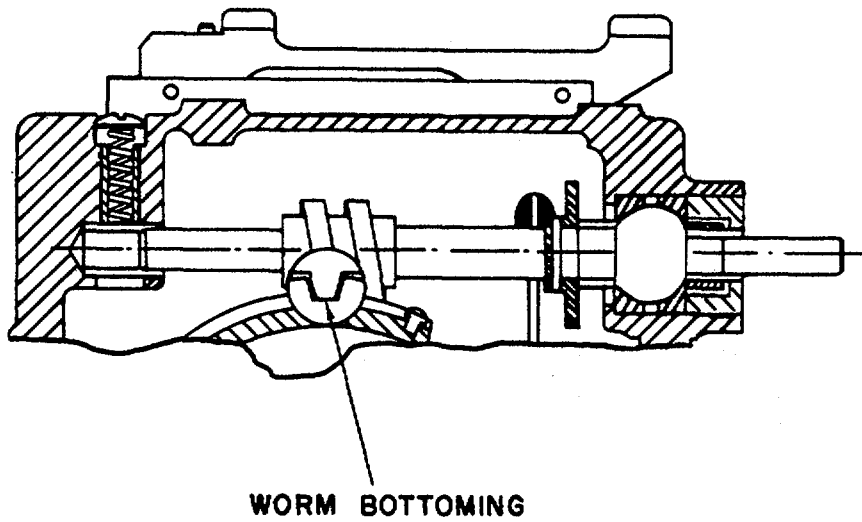

Figure 3-20. Worm Bottoming in Worm Gear

### 3-7. Worm and Worm Gear Mechanisms - Continued

- (4) End play. End play is the term applied to lengthwise movement of a shaft (fig. 3-21). Such movement, in a moderate degree, is acceptable when it does not contribute to the total backlash. Shafts are normally restricted longitudinally by shoulders, collars, thrust bearings, ball caps, and sockets, or by a combination of these. Seats, sockets, and wormshaft balls are commonly used for this purpose in military instruments, the wormshaft ball being held between the seat and the socket. If the ball cap is loose and the ball socket does not bear firmly and uniformly upon the ball, end play in the shaft will result. As the wormshaft is rotated, the slack between the ball and seat or socket must be taken up before the shaft will cause the worm gear to rotate.

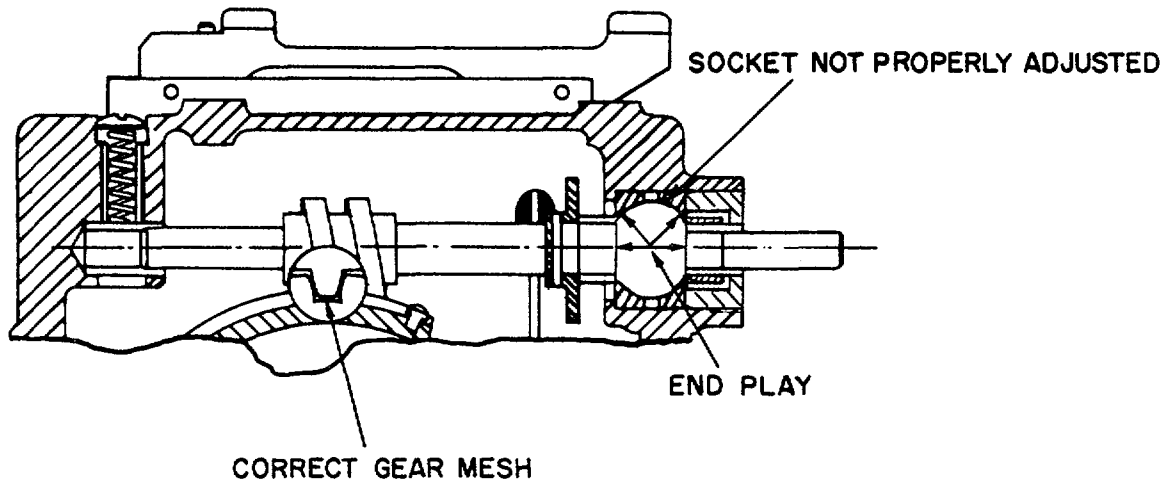

Figure 3-21. End Play in Wormshaft

- (5) Side play. Side play is the looseness or lateral movement, which is found in improperly fitted or worn bearing parts, such as the male and female conical bearing surfaces. Such movement should be reduced to an absolute minimum since it affects not only total backlash but also the proper setting of level vials attached to the instrument.
- (6) Backlash due to binding. This form of backlash occurs in screw type adjustments which depend upon steady spring pressure or retaining rings to eliminate lost motion or slack.
- (7) Reduction of backlash (fig. 3-15). On worm and worm gear mechanisms, backlash may be reduced by tightening the socket against the wormshaft ball. Backlash may sometimes be reduced by replacing the plunger spring. In cases of emergency only, the spring may be shimmed. Backlash may be eliminated by removing irregularities from the plunger which might prevent its movement or by filing away, or relieving, the shaft housing if the shaft bears against it. Bottoming of the worm may be eliminated by turning off a small amount of metal from the worm, worm gear, or both.

### 3-7. Worm and Worm Gear Mechanisms - Continued

g. Chatter. A chattering movement is usually an indication of a tight ball cap (fig. 3-15). If adjustment of the socket and ring does not cure the trouble without producing excessive backlash, the trouble is elsewhere.

- (1) The ball may be out-of-round or the socket and seat may not be properly lapped in.
- (2) The plunger spring (fig. 3-15) may be too tight or the worm not lubricated.
- (3) The dog-point screw, which keeps the ball socket from turning in the housing, may be too tight against the socket (fig. 3-22). The socket should be a slip fit in the housing. When the ball cap is brought against the ball, the socket will center itself on the ball, unless the dog-point screw or pin prevents it from doing so. When the socket is placed in the housing, see that the dog-point of the screw or pin is in the groove in the socket and that the socket is not binding in the housing. After the ball cap has been properly adjusted against the ball, adjust the dog-point screw until it touches the socket and then back it out about 1/4 turn. If the screw is tight against the socket, it is forcing the socket off center, thereby, producing a rough or chattering movement.

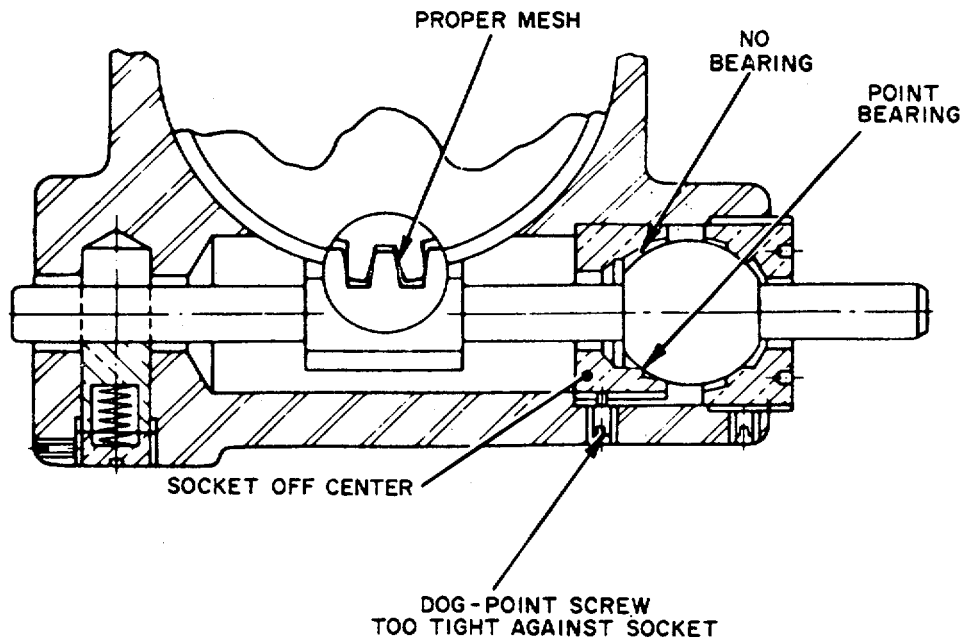

Figure 3-22. Dog-Point Screw Tight Against Socket

## 3-7. Worm and Worm Gear Mechanisms - Continued

h. Clicking.

- (1) This is something that can be felt when the worm knob is held between the thumb and forefinger and turned back and forth a few mils. Every time the rotation of the knob is reversed, the movement is loose for a short distance (1 to 3 mils) until a click or bump is felt in the knob when the lost motion has reached its limit. The reason for this is that the dog-point screw fits loosely in the threads of the housing, or in the groove of the socket, or a combination of both (fig. 3-23). Every time the motion of the knob is reversed the socket will move in the housing until the dog-point screw has cocked over to the other side. Once it is started, this clicking will grow progressively worse. This condition cannot be permitted because the loose spot is always at the setting point. Turn the knob in the opposite direction from which it was brought to the setting point, or fire the gun, and the instrument will be off the target. This loose spot in the movement is not lost motion which affects the accuracy of the instrument, but it makes the instrument unreliable because it will not hold a set reading. If this condition is found in an elevation or cross-leveling movement, watch the level vial bubble move off center when the knob is moved between the limits of the loose portion.

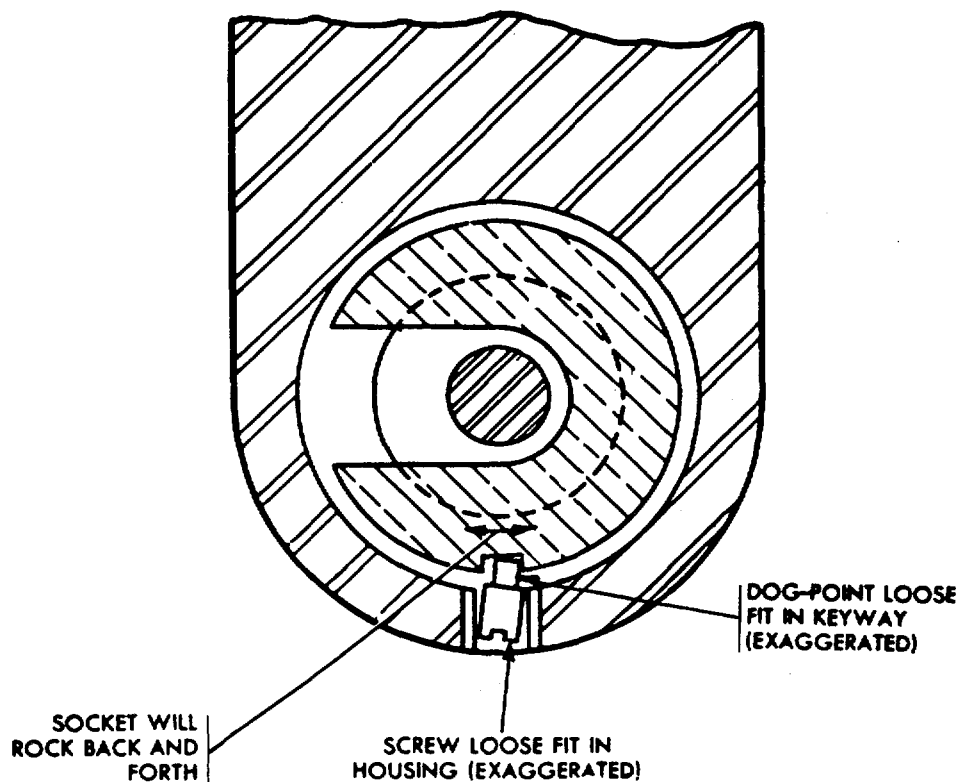

Figure 3-23. Dog-Point Screw Loose In Housing

**3-7. Worm and Worm Gear Mechanisms - Continued**

- (2) The only remedy for this condition is to install a screw that fits snugly in the housing and make sure that the dog-point fits in the slot of the socket.

i. Binding. A binding or uneven movement is caused by a bent worm, the presence of dirt between the worm and worm gear, or by a burr on one of the teeth. If a burr is present, remove it with a stone, file, or scraper. Polish the area with crocus cloth, clean and lubricate then assemble the parts and check that the movement is smooth.

**Section IV. TUBULAR LEVEL ASSEMBLIES****3-8. Level Vials.**

a. General. The ordinary tubular level vial is essentially a straight glass tube closed at both ends and partially filled with a liquid, leaving a small free space or bubble. The vial must provide the necessary accuracy and durability.

b. Uses. The tubular level vials are used in instruments to establish a true horizontal position for a known starting point of operation. Another use is to indicate the angular rotation of a mechanism in a vertical plane. The purpose of the markings is to indicate when a true horizontal plane exists.

c. Eccentric. The eccentric is an adjustable device to eliminate level vial error during final adjustments of the instrument. The reasons for using a two piece eccentric or a three piece eccentric are as follows:

- (1) A two piece eccentric is used to correct for slight defects in the level vial tube and level vial mount when setting up a true horizontal plane.
- (2) A three piece eccentric is used to correct for slight defects in the level vial tube and level vial mount when setting up a true horizontal plane that must also be rolled in a vertical axis.

d. Removal of Two Piece Eccentric and Tubular Level Vial (fig. 3-24). The proper method of removing a two piece eccentric and tubular level vial is as follows:

- (1) Use fabricated eccentric tool (5) (fabricate per fig. C-2, app C) to remove external threaded ring (4) and eccentric (3).
- (2) Rotate level vial cover (7) to gain access to the viewing slot of the level vial tube (2).
- (3) Insert a common straight blade screwdriver (6) or similar device into the exposed viewing slot of level vial tube (2). Carefully slide level vial tube from bracket (1) and level vial cover (7).
- (4) Remove straight pin (8) only if necessary to replace.

e. Installation of Two Piece Eccentric and Level Vial Tube (fig. 3-24). The proper method of installing a level vial tube and two piece eccentric is as follows:

**3-8. Level Vials - Continued****CAUTION**

**Straight pin (8) must not protrude more than one-sixteenth of an inch into the vial hole.**

- (1) If removed, press or drive straight pin (8) into bracket (1) so that the straight pin protrudes far enough into the level vial hole to engage the level vial tube (2).
- (2) Position the level vial cover (7) into bracket (1). Slide the level vial tube (2) into the bracket and cover so the slot in the end of the level tube engages the straight pin (8).
- (3) Install eccentric (3) and external threaded ring (4) into bracket (1) but do not tighten pending final adjustment.

f. Final Adjustment of a Two Piece Eccentric and Level Vial Tube (fig. 3-24). The final adjustment of the level assembly is performed after it has been installed on the instrument and set up on the cross-leveling and elevation fixture.

- (1) Engage fabricated eccentric tool (5) to the external threaded ring (4).
- (2) Insert a common straight blade screwdriver (6) through the center hole in the fabricated eccentric tool (5) and engage eccentric (3).
- (3) Adjust eccentric (3) until the level vial bubble is centered within the graduations on the level vial tube (2).
- (4) Hold the eccentric (3) firmly in place while turning fabricated eccentric tool (5) with a wrench to tighten external threaded ring (4). Be careful not to disturb the setting of level vial tube (2).

g. Removal of Three Piece Eccentric and Tubular Level Vial (fig. 3-25). The proper method of removing a three piece eccentric and tubular level vial is as follows:

- (1) Using a fabricated eccentric tool (8) (fabricate per fig. C-3, app C) to remove ring (7), eccentric ring (6), and eccentric (5).
- (2) Rotate level vial cover (1) to gain access to the viewing slot of the level vial tube (4).
- (3) Insert a common straight blade screwdriver or similar device into the exposed viewing slot of level vial tube (4). Carefully slide level vial tube from machined rocker (3) and level vial cover (1).
- (4) Remove straight pin (2) only if necessary to replace.

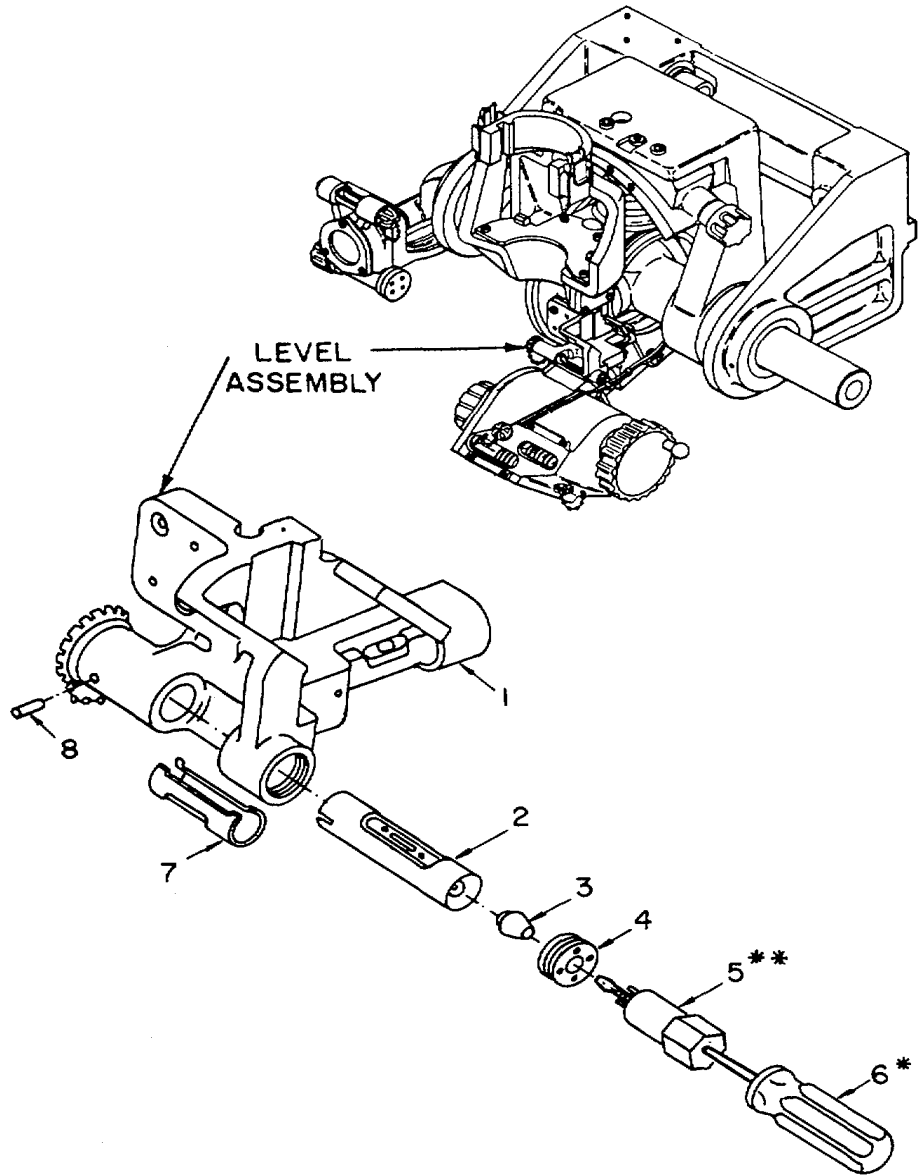

\* SCREWDRIVER USED DURING ADJUSTMENT PROCEDURE ONLY.  
 \*\* FABRICATED TOOL USED DURING ADJUSTMENT PROCEDURE ONLY.

KEY to figure 3-24:

- |                            |                                       |
|----------------------------|---------------------------------------|
| 1. Bracket                 | 5. Tool, fabricated eccentric         |
| 2. Tube, level vial        | 6. Screwdriver, common-straight blade |
| 3. Eccentric               | 7. Cover, level vial                  |
| 4. Ring, external threaded | 8. Pin, straight                      |

Figure 3-24. Level Vial with Two Piece Eccentric



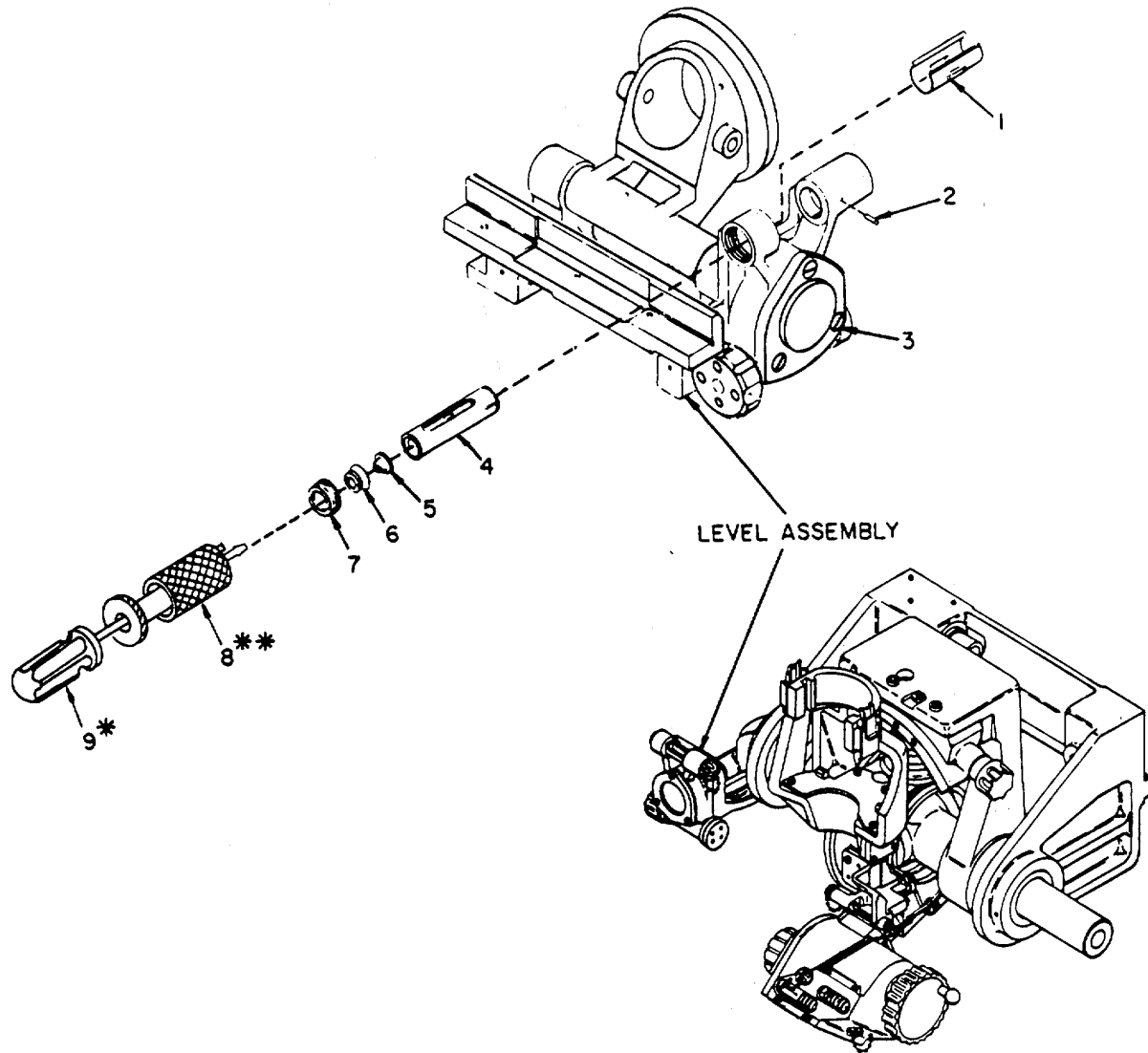

\* SCREWDRIVER USED DURING ADJUSTMENT PROCEDURE ONLY.

\*\* FABRICATED TOOL USED DURING ADJUSTMENT PROCEDURE ONLY.

KEY to figure 3-25:

- |                      |                                       |
|----------------------|---------------------------------------|
| 1. Cover, level vial | 6. Ring, eccentric                    |
| 2. Pin, straight     | 7. Plug                               |
| 3. Machined rocker   | 8. Tool, fabricated eccentric         |
| 4. Tube, level vial  | 9. Screwdriver, common-straight blade |
| 5. Eccentric         |                                       |

Figure 3-25. Level Vial with Three Piece Eccentric

### 3-8. Level Vials - Continued

h. Installation of Three Piece Eccentric and Level Vial Tube (fig. 3-25). The proper method for installing a level vial tube and three piece eccentric is as follows:

#### Caution

**The straight pin must not protrude more than one-sixteenth of an inch into the vial hole.**

#### NOTE

**Check level vial tube (4) on surface plate to insure that the bubble is within 1 to 1-1/2 graduations of being level before installing into the rocker and cover.**

- (1) If removed, press or drive straight pin (2) into bonded and machined rocker (3) so that the straight pin protrudes far enough into the level vial hole to engage the level vial tube.
- (2) Position the level vial cover (1) into bonded and machined rocker (3). Slide the level vial tube (4) into the rocker and cover so the slot in the end of the level vial tube engages the straight pin (2).
- (3) Install eccentric (5), eccentric ring (6), and plug (7) into machined rocker (3) but do not tighten pending final adjustment.

i. Final Adjustment of a Three Piece Eccentric and Level Vial Tube (fig. 3-25). The final adjustment of the level assembly is performed after it has been installed on the instrument and set up on the cross-leveling and elevation fixture.

- (1) Engage fabricated eccentric tool (8) into eccentric ring (6) and plug (7).
- (2) Insert a common straight blade screwdriver (9) through the center hole in the fabricated eccentric tool (8) and engage eccentric (5).
- (3) Adjust eccentric (5) and eccentric ring (6) until the level vial bubble is centered within the graduations on the level vial tube (4).
- (4) Rotate level assembly from 0 mils to 1330 mils and adjust eccentric (5) and eccentric ring (6) until the level vial bubble is centered within the graduations on the level vial tube (4).
- (5) Rotate level assembly from 1330 mils to 0 mils and adjust eccentric (5) and eccentric ring (6) until the level vial bubble is centered within the graduations on the level vial tube (4).
- (6) Repeat steps (4) and (5) as necessary to level the vial at 0 mils and 1330 mils.
- (7) Hold the inner portion of the fabricated eccentric tool (8) firmly in place while turning the outer portion of the fabricated eccentric tool to tighten plug (7). Be careful not to disturb the setting of level vial tube (4).

## Section V. INSTALLATION OF HELICAL INSERTS AND REMOVAL OF DAMAGED SETSCREWS

### 3-9. Helical Inserts.

a. General. Helical inserts are used to prevent a hard steel bolt or screw from damaging the threads in softer metal such as aluminum castings.

b. Installing Helical Inserts. Helical inserts are sized according to the diameter and number of threads per inch. Select the appropriate size helical insert and install as follows:

#### NOTE

- o **For a blind hole, the length of insert must be selected to insure that a clearance of one-eighth of an inch exists from the bottom of the hole to tang of the insert.**
- o **For a through hole, the length of insert must be selected to insure that the tang of the insert mounts flush with the bottom of the hole.**

- (1) Retract the mandrel of the helical inserting tool (fig. 3-26) and place a helical insert into the chamber with the tang end of the insert toward the chuck.
- (2) Advance the mandrel until it fully engages the insert tang. Continue turning the mandrel, advancing the insert into the chuck until the mandrel and insert are flush with the tip of the chuck.
- (3) Hold the inserting tool firmly and squarely against the work with the insert aligned with the tapped hole (fig. 3-27).
- (4) Rotate the handle clockwise at a slow uniform rate until the top coil of the insert is 1/4 to 1/2 turn below the top work surface of the hole.
- (5) Rotate the handle counterclockwise to remove mandrel from hole.
- (6) Place the punch end of tang break-off tool (2, fig. 3-28) into the center of the insert, resting the tool squarely on the insert tang.
- (7) Strike the top of the tool with a sharp blow using a soft-faced hammer to break tang from insert.
- (8) If needed, use long narrow tweezers to remove the tang from insert hole.

c. Extracting Inserts (fig. 3-29). Helical inserts must be removed when they are bent, broken or improperly installed. To remove an insert:

- (1) Position the blade of the extracting tool into the center of the insert.
- (2) Tap the top of the extracting tool with a hammer to seat the tool into the insert.

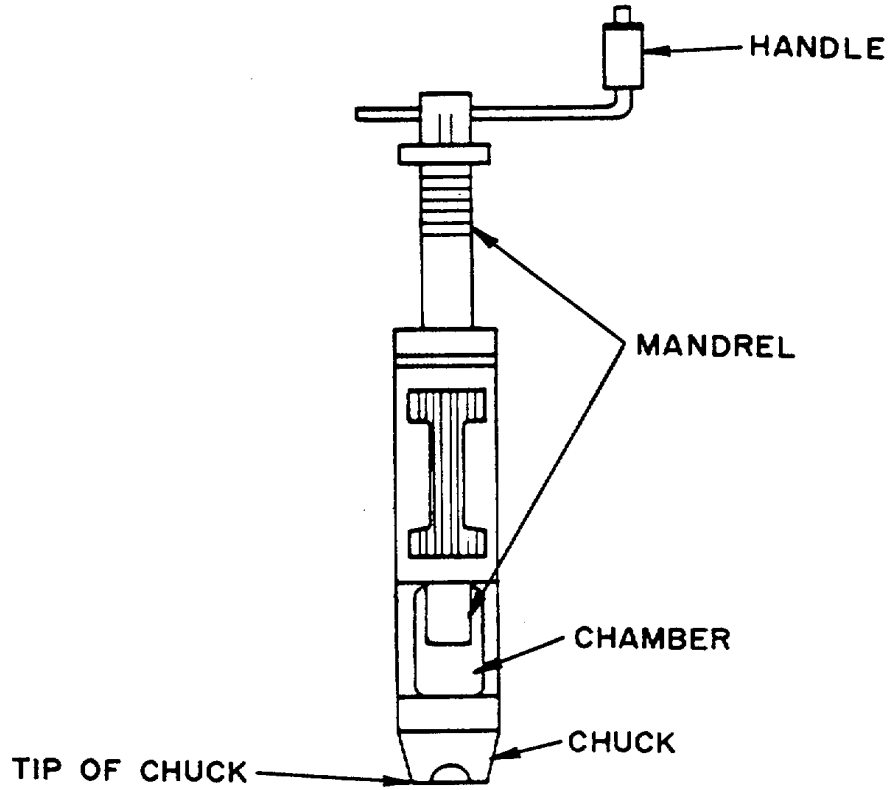

Figure 3-26. Helical Inserting Tool

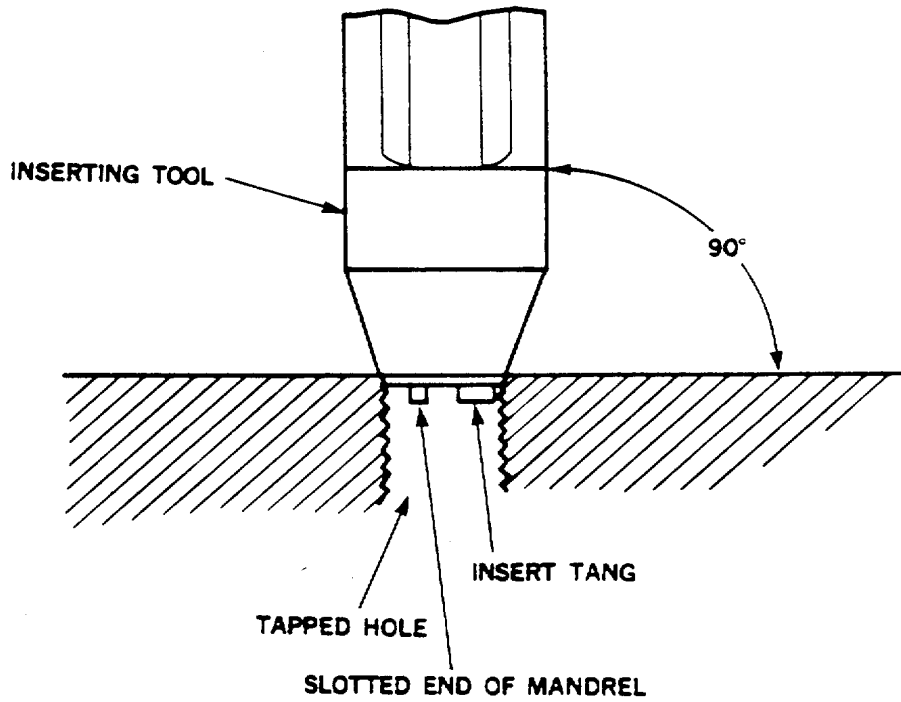

Figure 3-27. Installing Helical Insert

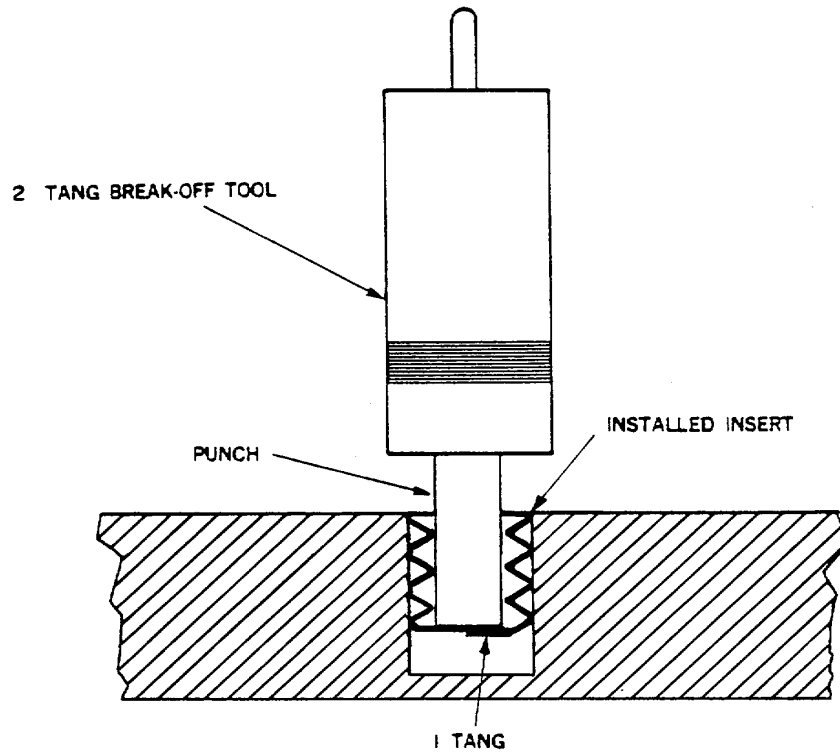

Figure 3-28. Removing insert Tang

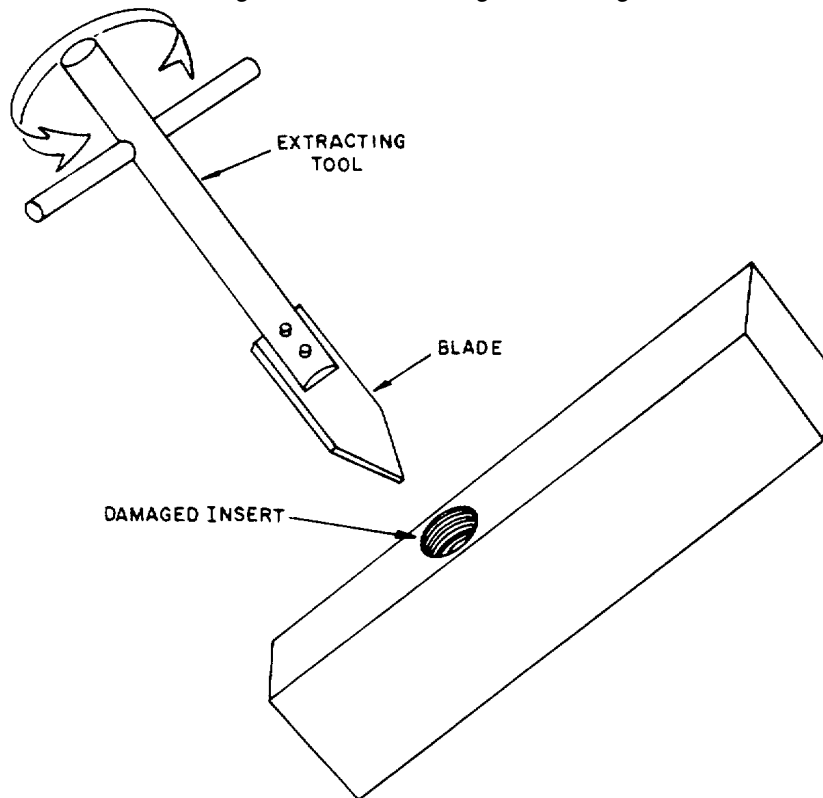

Figure 3-29. Extracting Insert

### 3-9. Helical Inserts - Continued

- (3) Push down on the extracting tool and turn counterclockwise to back the insert out of the hole.
- (4) Discard the insert. Never reuse an insert.

### 3-10. Removal of Setscrews.

a. General. The securing of mechanical components is frequently accomplished by the use of setscrews. Disassembly of components without removing these setscrews is probably the greatest cause of damage to fire control instruments during the inspection or repair process. Many setscrews are covered with sealing compound and paint. Some setscrews may be installed with setscrews on top of setscrews to lock them in place. Perform an inspection of the instrument before disassembly is attempted.

b. Removal of Ordinary Setscrews (Undamaged). Examine the instrument and components for the presence of setscrews. The technical manual for the instrument must be reviewed if there is any doubt concerning the presence of setscrews. When the setscrew has been located, remove paint and sealing compound with a scribe or jewelers' screwdriver. When the head of the screw can be seen, insert a screwdriver or Allen wrench of the proper size and remove the screw.

c. Precautions. If the screw will not back out when normal pressure is applied with the screwdriver or allen wrench, do not force it. It may have been sealed in position with shellac or another fixing agent. If so, apply a few drops of alcohol to the screwhead and allow it to soak for a few minutes. Again insert the screwdriver or hex key wrench and exert a slight back and forth pressure. It may be necessary to apply heat to the area around the setscrew to loosen the sealing compound in order to remove the setscrew.

d. Removal of Damaged Setscrews. If the slot of a setscrew below the surface is damaged, the best method is to drill out the screw and retap the hole.

- (1) Select a tap drill of the size for the setscrew which will be used as a replacement.
- (2) Position the part to be drilled securely on the drill press with the drill centered on the setscrew, and drill out the setscrew.
- (3) If the setscrew is not too small, it may be possible to remove it with a screw extractor (fig. 3-30).
- (4) Another method of removing setscrews is by using an insert extractor tool of the same size that will fit the screw opening, as shown in figure 3-29.
- (5) If the setscrew is above surface, it may be possible to slot it sufficiently with a small file or hacksaw blade (fig. 3-31).
- (6) A setscrew that can be turned, but which does not back out, indicates a stripped thread condition. It may be possible to back out the setscrew if the parts held together by the setscrew can be turned enough to put a slight stress on the setscrew. This will allow those threads still undamaged to engage and enable the repairer to remove the setscrew.

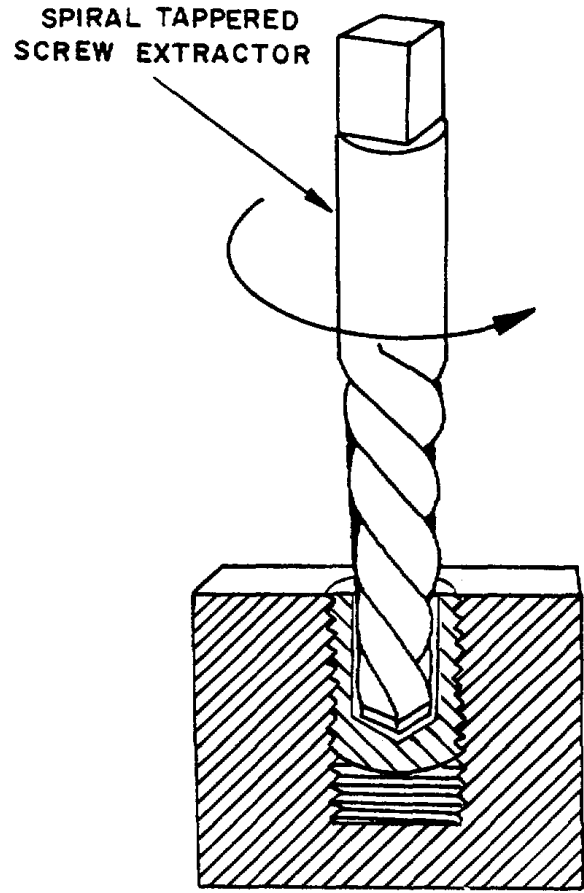

Figure 3-30. Using Spiral Tapered Screw Extractor

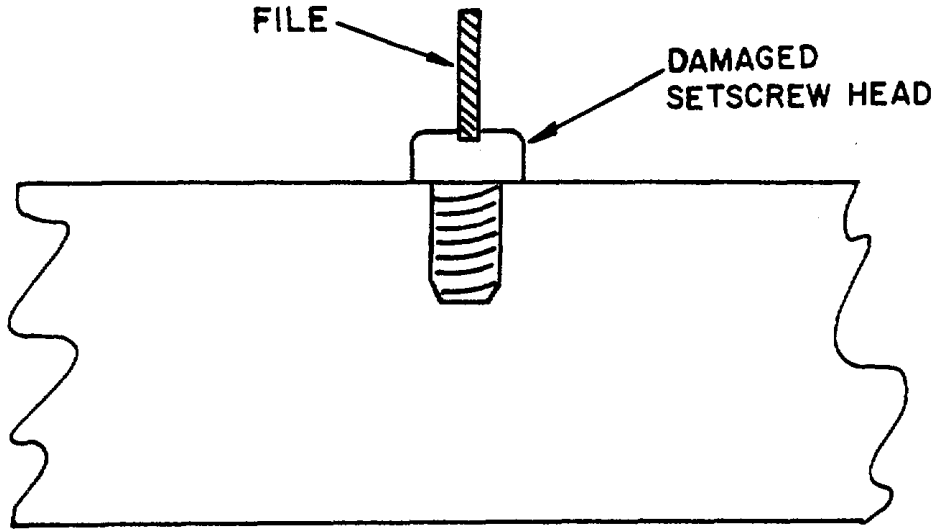

Figure 3-31. Slotting Damaged Setscrew

## Section VI. HANDLING, USING, AND STORING EXPENDABLES

### 3-11. General.

This section contains general instructions for handling, using, and storing expendable material such as adhesives, solvents, coatings, lubricants, sealing compounds, and silicone heat sink.

### 3-12. Handling Expendables.

#### WARNING

**Use adhesives, cleaning solvents, and sealing compounds in a well ventilated area away from open flames. Adhesives, cleaning solvents, and sealing compounds are harmful to skin and clothing, can burn easily, and may give off harmful vapor.**

Before using any expendable material, always read the label attached to the container. Abide by all warnings and instructions that may be listed on the container label. When using material that is supplied in large containers, always pour or separate the amount necessary to perform the job, into a smaller container. This practice will eliminate the possibility of contaminating the larger container. Never pour any unused portions back into the original container as this may also cause contamination. Use only clean brushes for applying expendables to prevent mixing of materials and always clean brushes immediately after use.

### 3-13. Using Expendables.

a. Adhesives. Adhesives are used to fasten items together. An example would be, using adhesive to fasten gaskets, seals or pads.

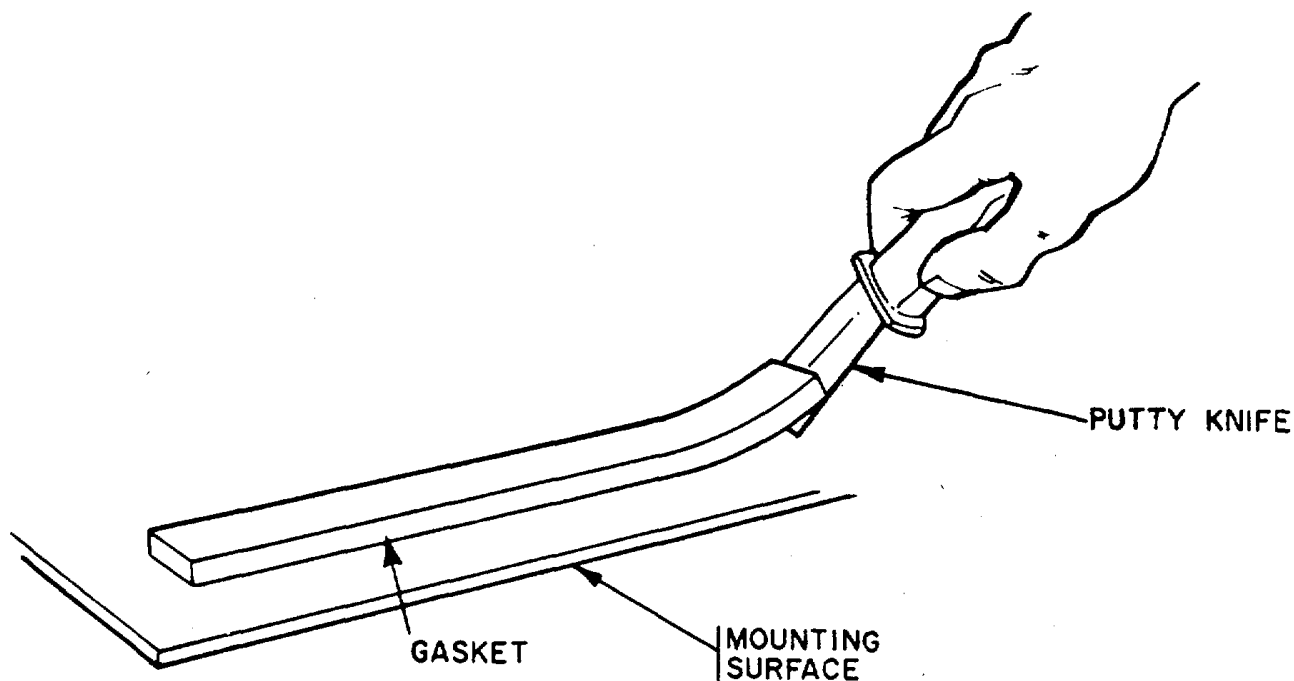

Figure 3-32. Removing Old Gasket Material



**3-13. Using Expendables - Continued****NOTE**

In steps (1) through (3), refer to figure 3-32.

- (1) To prepare a surface for mounting a gasket, seal or pad, use a knife or chisel to peel and scrape away old material.
- (2) Use a clean cloth, moist but not dripping, with a cleaning solvent and wipe the mounting surface clean of old adhesive and dirt.
- (3) Use clean, dry cloth and wipe the mounting surface dry.

**NOTE**

In steps (4) through (6), refer to figure 3-33.

- (4) Using a paint brush, apply a thin even coat of adhesive to the gasket or seal and on the mounting surface. Allow the adhesive to air dry completely.
- (5) Apply another thin even coat of adhesive to the gasket or seal and to the mounting surface. Allow adhesive to air dry until it becomes tacky.
- (6) Press the gasket or seal in place and apply a firm even pressure over the entire surface

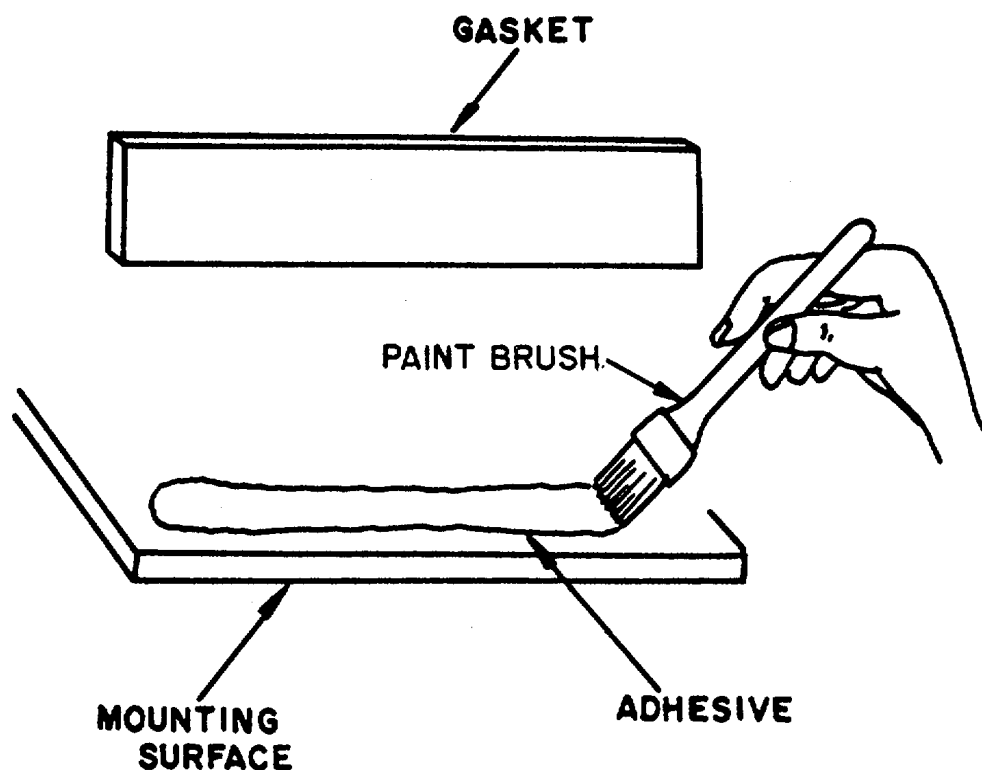

Figure 3-33. Applying Adhesives

## 3-13. Using Expendables - Continued

**WARNING**

Use adhesives, cleaning solvents, and sealing compounds in a well ventilated area away from open flames. Adhesives, cleaning solvents, and sealing compounds are harmful to skin and clothing, can burn easily, and may give off harmful vapor.

b. Solvents. Cleaning with solvents is performed mainly for the purpose of removing dirt, grease, oil, flux, and cementing compound from surfaces.

- (1) If the item is too large to be totally immersed in the cleaning solvent, a clean cloth or paint brush may be used to apply the solvent. Dip the cloth or brush into the solvent and rub over the surface to be cleaned. Use a clean, dry cloth and wipe the surface dry. Repeat as many times as necessary.
- (2) Small parts may be cleaned in an immersion tank filled with solvent. If a tank is not available, simply use a 5-gallon can filled with cleaning solvent and a stiff brush to scrub parts while cleaning. Immerse the smaller parts in the can and scrub clean with the brush. After the parts are cleaned, remove them from the solvent and either air dry or wipe dry with a clean, dry cloth.

c. Coatings (fig. 3-34). Coatings are designed to prevent the growth of fungus on organic materials, corrosion of metal parts, and the absorption of moisture by insulating materials. An example of coating would be the moisture and fungus proofing of an electronic circuit board described below:

- (1) After soldering the circuit connections (1) remove all flux residue with alcohol and a brush.

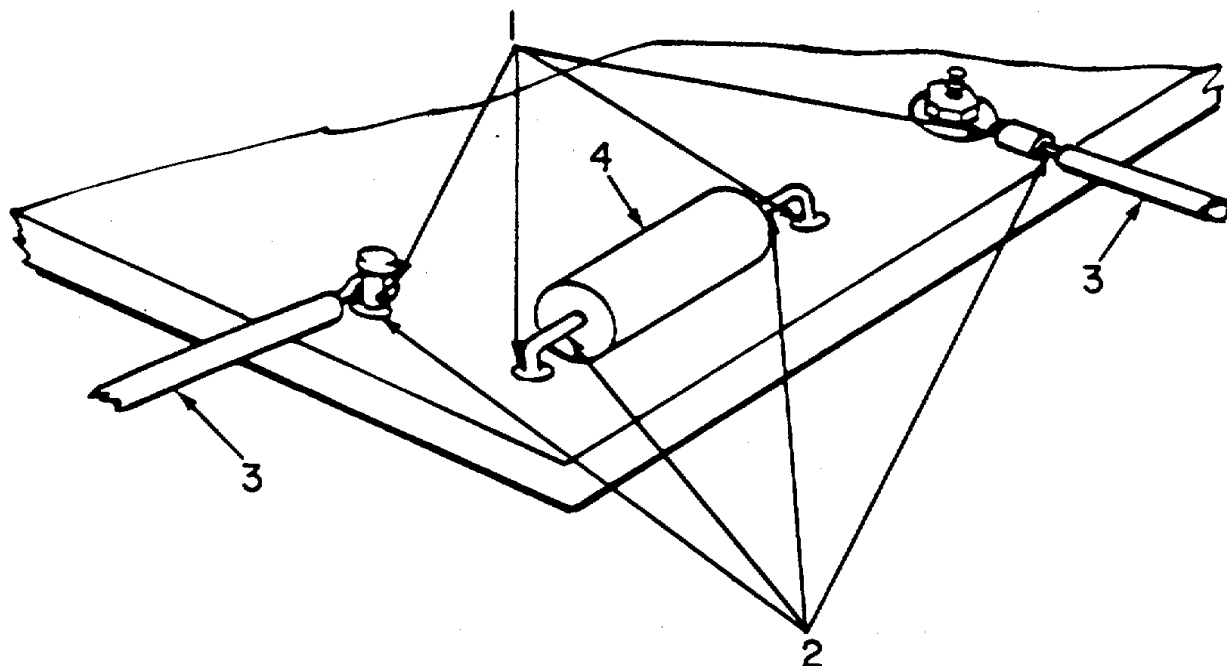

Figure 3-34. Moisture and Fungus Proofing an Electronic Circuit Board

**3-13. Using Expendables - Continued**

- (2) Using a small artist's brush, apply a light coating of fungus proof varnish to the solder joints (1) and exposed wire (2) and approximately 1/4 of an inch of the insulation (3).
- (3) If a component (4) has been replaced, coat the entire component with fungus proof varnish.
- (4) Allow the fungus proof varnish to dry completely.

d. Lubricants. Some of the lubricants used to maintain fire control equipment are aircraft and instrument grease, special preservative lubricating oil, and graphite-petrolatum antiseize compound. Grease, compound, and oil should be used sparingly since the aim of good lubrication is to apply a minimum amount of lubricant consistent with adequate lubrication. Thoroughly clean and dry all parts before lubrication. The general application of lubricants upon assembly is as follows:

- (1) Clean all parts to be lubricated using a clean cloth, moist but not dripping, with a cleaning solvent. Remove all dirt and grease then dry the parts using a second clean, dry cloth.
- (2) Clean rubber parts using a clean cloth, moist but not dripping with mild soap and water.
- (3) Use a clean brush or cloth to apply grease and a hand oiler (fig. 3-35) to apply light weight oil.

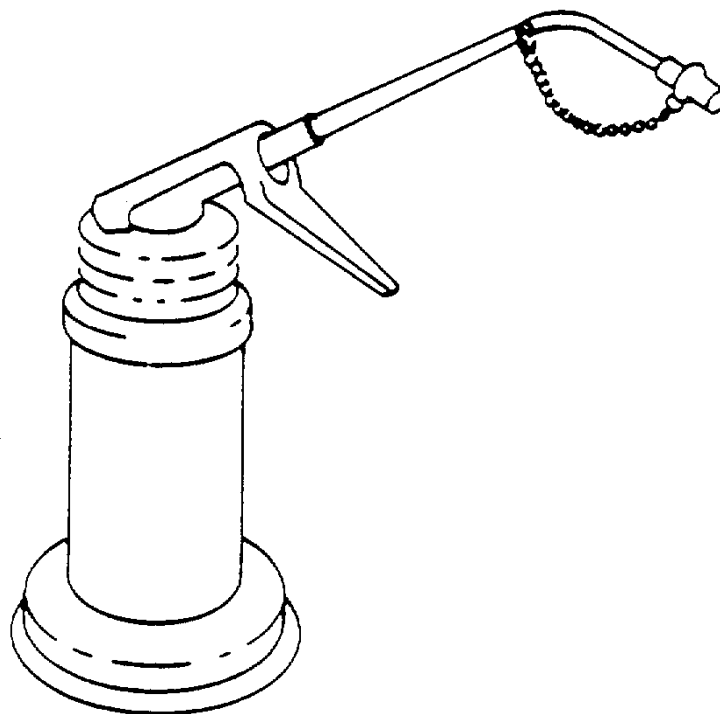

*Figure 3-35. Hand Oiler*

- (4) Never put a dirty brush into clean grease. If brush is dirty, dip into a cleaning solvent and wipe dry with a clean cloth.

**NOTE**

**In steps (5) through (9), refer to figure 3-36.**

**3-13. Using Expendables - Continued**

- (5) Before greasing a bearing, it must first be cleaned of all dirt, oil, and grease. To clean the bearing, completely immerse it in cleaning solvent and agitate the bearing back and forth.

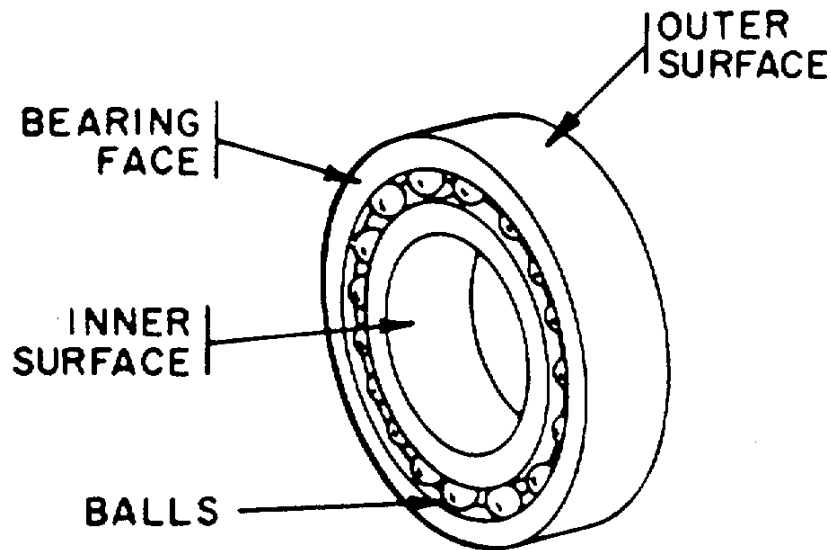

*Figure 3-36. Applying Grease to Bearing*

- (6) Remove bearing from the cleaning solvent. Blow dry using low-pressure air or allow it to air dry completely before applying grease.
- (7) Using fingers, apply grease to the balls of the bearing and press the grease into the spaces between the balls.
- (8) Turn the bearing over and apply grease as described in step (7) to the opposite side of the bearing. Rotate bearing to distribute grease evenly.
- (9) Use a clean, dry cloth to remove excess grease from the bearing.

**CAUTION**

**Use care when lubricating beaded seals that are made of metal plates and contain rubber like gaskets. Grease should be applied only to the very top of gasket and not to the sides.**

**NOTE**

**In steps (10) and (11), refer to figure 3-37.**

- (10) Apply a thin film of grease only to the top of the gaskets (fig. 3-37).

**NOTE**

**There is a gasket located on both sides of the metal plate as shown in figure 3-37.**

## 3-13. Using Expendables - Continued

(11) To lubricate, apply a thin, even film of silicone grease to the top of the caskets.

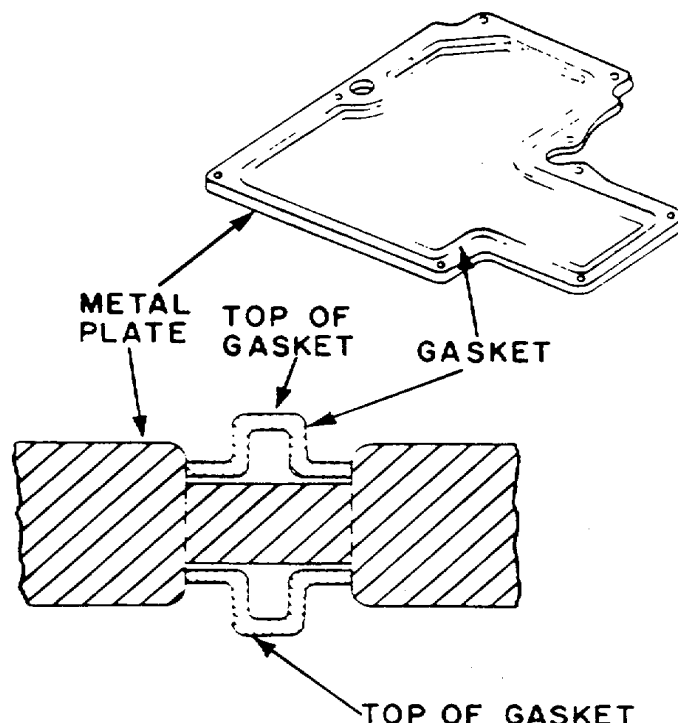

Figure 3-37. Applying Grease to Beaded Seal

e. Sealing Compound. Sealing compounds are used as a bonding agent to bond metal to metal or glass to metal in optical or fire control instruments. It can be used to install gaskets, windows, lenses, and setscrews where a firm air tight seal is necessary. Sealing compounds are divided into two categories, curing and non-curing. A curing type sealing compound is made up of two individual agents, a base and an accelerator that are mixed together just before using. A non-curing sealing compound contains one base agent, and does not require mixing prior to its use. The removal and application of a curing type sealing compound is described as follows:

**NOTE**

In steps (1) through (3), refer to figure 3-38.

- (1) Remove old sealing compound from the top of the setscrew, with a tool such as a scribe or jewelers' screwdriver. Loosen and dig out the old compound until the head of the setscrew can be seen.

**NOTE**

If the setscrew begins to bind or get tight during removal, do not force it. Turn the setscrew clockwise and then counterclockwise, trying to loosen the setscrew a few threads at a time until it can be completely removed. It may be necessary to apply heat to the area around the setscrew to loosen the sealing compound.

**3-13. Using Expendables - Continued**

- (2) Using a screwdriver or hex key wrench, press firmly into the slot of the setscrew and remove.
- (3) Remove all traces of old sealing compound that remain in the hole.

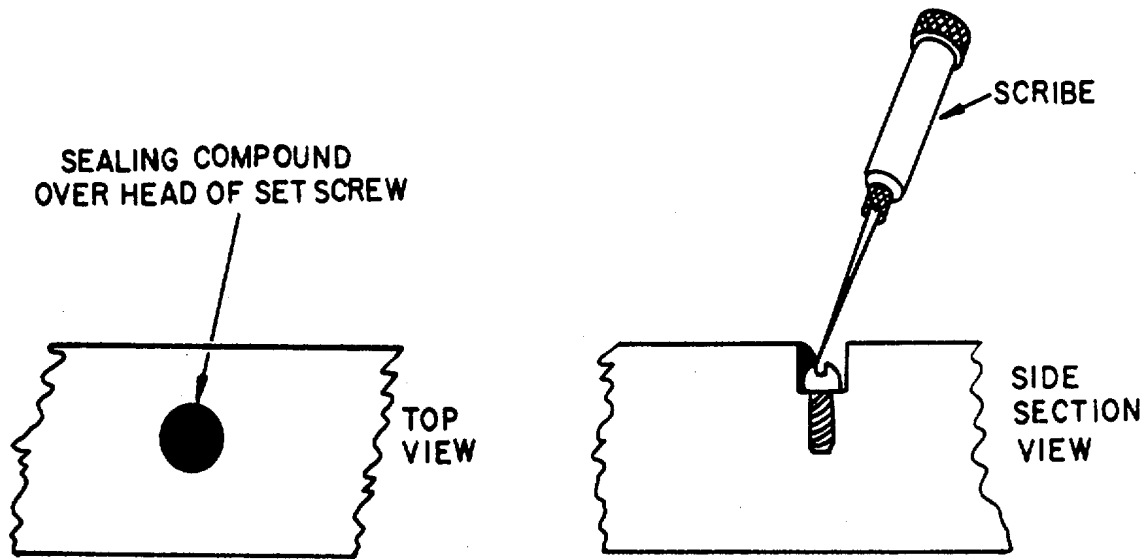

*Figure 3-38. Removing Sealing Compound from a Setscrew*

**NOTE**

**In steps (4) through (6), refer to figure 3-39.**

- (4) If a curing type sealing compound is selected to seal the setscrew, it must be mixed. Use a clean screwdriver or putty knife and scoop the base material from its container into a larger mixing container. Use only enough base material to do the job at hand. When the accelerator is mixed into the base material, the sealing compound will harden with time and cannot be reused.
- (5) Clean off the blade of the screwdriver or putty knife with a clean cloth and then scoop the required amount of accelerator from its container into the mixing container with the base material.
- (6) Use the screwdriver or putty knife, and with a circular stirring motion, start at the center of the mixing container and move toward the edge of the container. Repeat stirring motion until the two materials are completely mixed.

## 3-13. Using Expendables - Continued

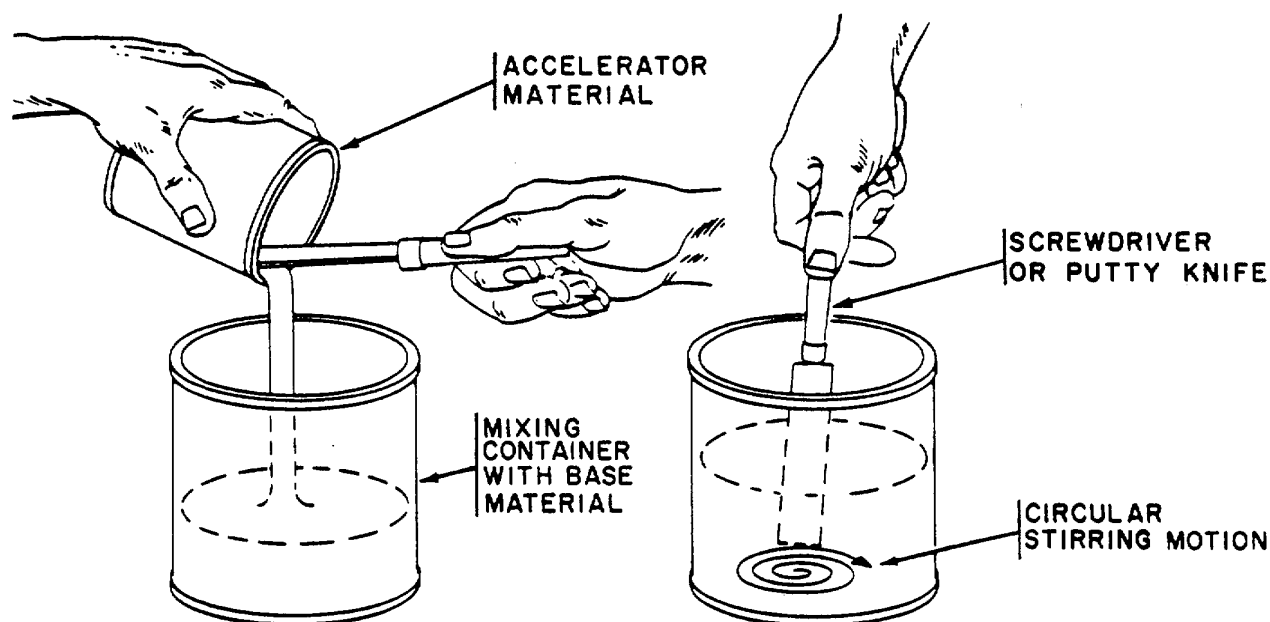

Figure 3-39. Mixing Two Part Curing Type Sealing Compound

**NOTE**

In steps (7) through (9), refer to figure 3-40.

- (7) Install the setscrew into the hole until it is securely seated. Dip the tip of a scribe or similar device into the curing type sealing compound, and apply it to the head of the setscrew until the hole is filled. Allow enough time for the sealing compound to cure and remove excess sealing compound with a single edge razor blade or knife.
- (8) Clean scribe tip with a clean cloth and cleaning solvent to remove all traces of sealing compound.
- (9) Dispose of any unused portion of the curing type sealing compound after the job is completed.

**NOTE**

In steps (10) through (14) refer to figure 3-41.

- (10) To apply sealing compound to the internal groove of a cover, first remove two setscrews (6) and (3) to gain access to the groove.
- (11) Use a sealing gun, filled with sealing compound and the correct adapter to inject the sealing compound into the groove through hole (1).
- (12) Fill internal groove until the sealing compound comes out of hole (2). Install setscrew (6) into hole (1) and remove setscrew (5).

3-13. Using Expendables - Continued

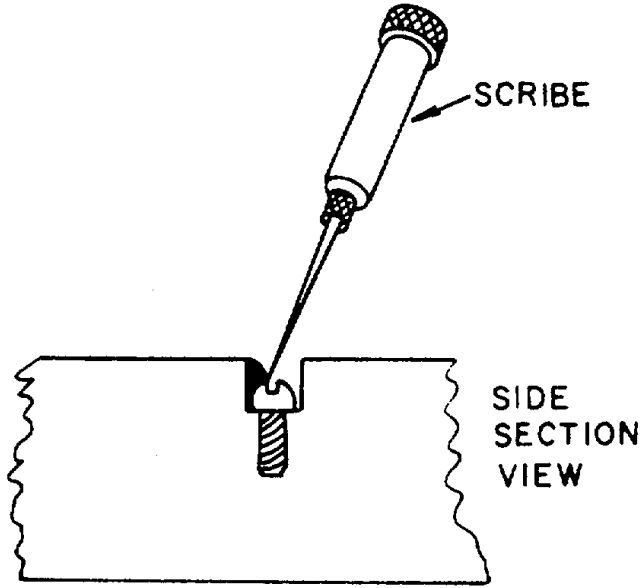

Figure 3-40. Applying Sealing Compound to a Setscrew

- (13) Insert sealing gun into hole (2) and fill internal groove until sealing compound comes out hole (4). Install setscrew (3) into hole (2) and remove setscrew (6).
- (14) Insert sealing gun into hole (4) and fill internal groove until sealing compound comes out hole (1). Install setscrew (5) and (6). Figure 3-41. Sealing Internal Groove

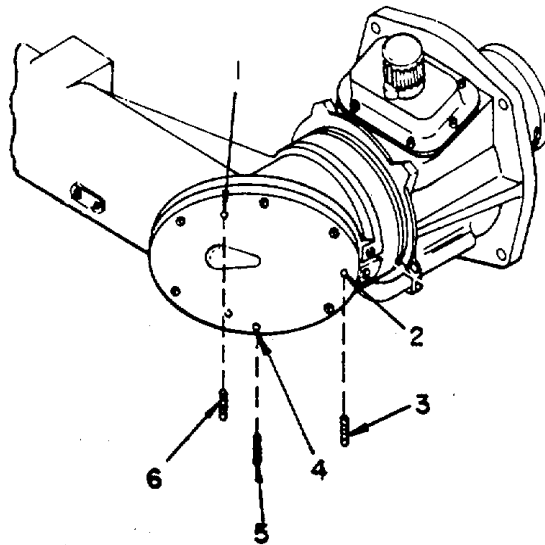

Figure 3-41. Sealing Internal Groove

f. Silicone Heat Sink Compound (fig. 3-42). Insulating compound acts as a heat conductor to dissipate heat generated by the electrical components and as an electrical insulator. A general procedure for the application of a silicone type insulating compound is described below:



### 3-13. Using Expendables - Continued

- (1) Silicone compound is used as an insulator and heat dissipator when replacing surface mounting transistors (1) in electrical circuits.
- (2) Remove two hex nuts (5), two insulators (6), and two machine screws (2) from the chassis (3). Remove transistor (1) and mica washer (7) from the chassis.
- (3) Clean the mounting surface of chassis (3) with alcohol and a brush or a clean cloth.
- (4) Spread a thin even coating to the bottom surface of the replacement transistor (1) and to both sides of the replacement mica washer (7).

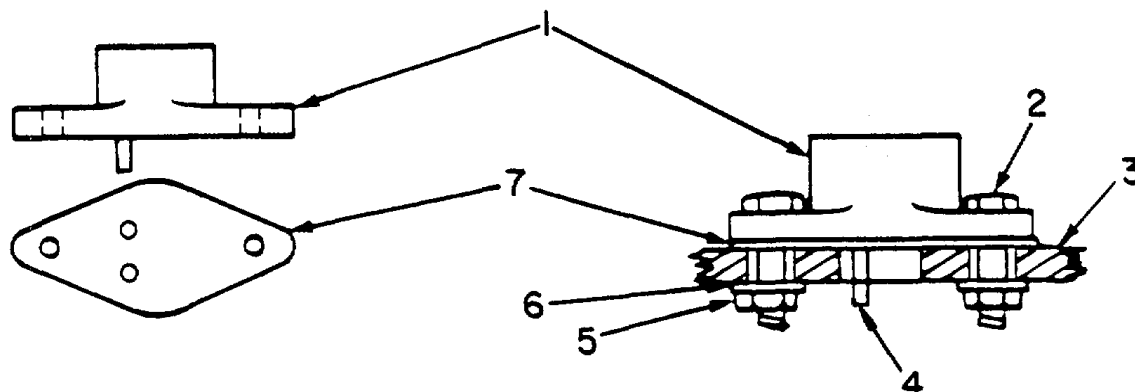

KEY to figure 3-42:

- |                       |                  |
|-----------------------|------------------|
| 1. Transistor         | 5. Nut, hex (2)  |
| 2. Screw, machine (2) | 6. Insulator (2) |
| 3. Chassis            | 7. Washer, mica  |
| 4. Leads, transistor  |                  |

Figure 3-42. Applying Insulating Compound on a Transistor

- (5) Position the mica washer (7) on the bottom of the replacement transistor (1) with the leads of the transistor protruding through the two holes in the center of the mica washer.
- (6) Align the mounting holes in the mica washer (7) with the mounting holes in the replacement transistor (1) and insert two machine screws (2).
- (7) Align the two machine screws (2) and the two leads (4) of the replacement transistor (1) with the holes in the chassis (3) and press in place.
- (8) Position two insulators (6) and install two hex nuts (5) onto the two machine screws (2) and tighten securely.
- (9) Use a clean, dry cloth to wipe off any excess silicone compound from around the base of the transistor.

g. Heat Shrinkable Sleeving (fig. 3-43). Heat shrinkable sleeving is used to cover solder joints on variable resistor terminals, relay terminals, switch terminals, transformer terminals, and connector pins. A general procedure for installing heat shrinkable sleeving is described below:

### 3-13. Using Expendables - Continued

- (1) Determine the appropriate size of heat shrinkable sleeving necessary to do the job.
- (2) Slide the heat shrinkable sleeving over the wire before inserting the wire into the cup terminal.
- (3) Solder wire to cup terminal using soldering techniques described in chapter 4.
- (4) Slide heat shrinkable sleeving down wire until it covers all bare wire and the upper part of the cup terminal.

#### CAUTION

Apply only enough heat to shrink the sleeving to conform to the shape of the joint. Over heating of the heat shrinkable sleeving will cause it to melt and tear.

- (5) Use a heat gun or hair dryer to apply heat to the heat shrinkable sleeving for approximately 4 seconds.
- (6) Allow heat shrinkable sleeving to cool and inspect for a snug fit against the joint. If necessary repeat step (5) above to a snug fit.

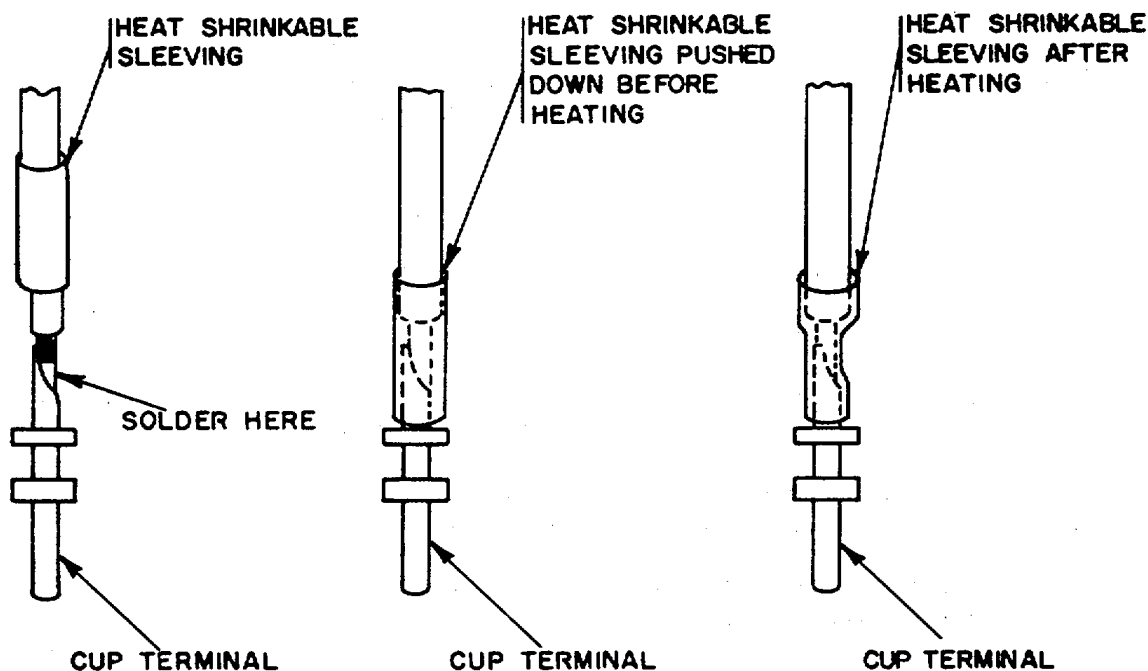

Figure 3-43. Use of Heat Shrinkable Sleeving

### 3-14. Storing Expendables.

Close all containers tightly when they are not being used. Keep container labels clean so that they can be easily read. Store flammable materials in an approved metal cabinet and away from heat sources.

## Section VII. SAFE STORAGE OF LOOSE PARTS

### 3-15. General.

During disassembly and assembly operations, temporary preservation procedures are required in order to protect parts from contamination and corrosion. Small loose parts from units that are disassembled should be kept in a plastic storage container. Larger assemblies should have all openings covered with lens paper, and sealed with tape to prevent entrance of airborne dirt and moisture.

### 3-16. Storage Containers.

a. Plastic Storage Container (fig. 3-44). When units are being disassembled, loose parts from these units should be placed in plastic storage containers in a logical order of disassembly. Use a separate storage container for each assembly or subassembly and label each tray.

- (1) Use plastic storage containers with a top if available, to keep loose parts separate and in order so that reassembly may be made easier.
- (2) If mechanical parts are to be stored in the trays for a few days before assembly, do not remove the old grease. A perfectly clean metal will corrode.
- (3) Optics which are being held for inspection or installation should be covered with lens paper and sealed in polyethylene bags.
- (4) Store the plastic storage containers containing parts in a safe area where they will not be lost or knocked over.

b. Polyethylene Bags (fig. 3-44). If plastic storage containers are not available, store loose parts in various sizes of polyethylene bags. Label bags to indicate order of disassembly.

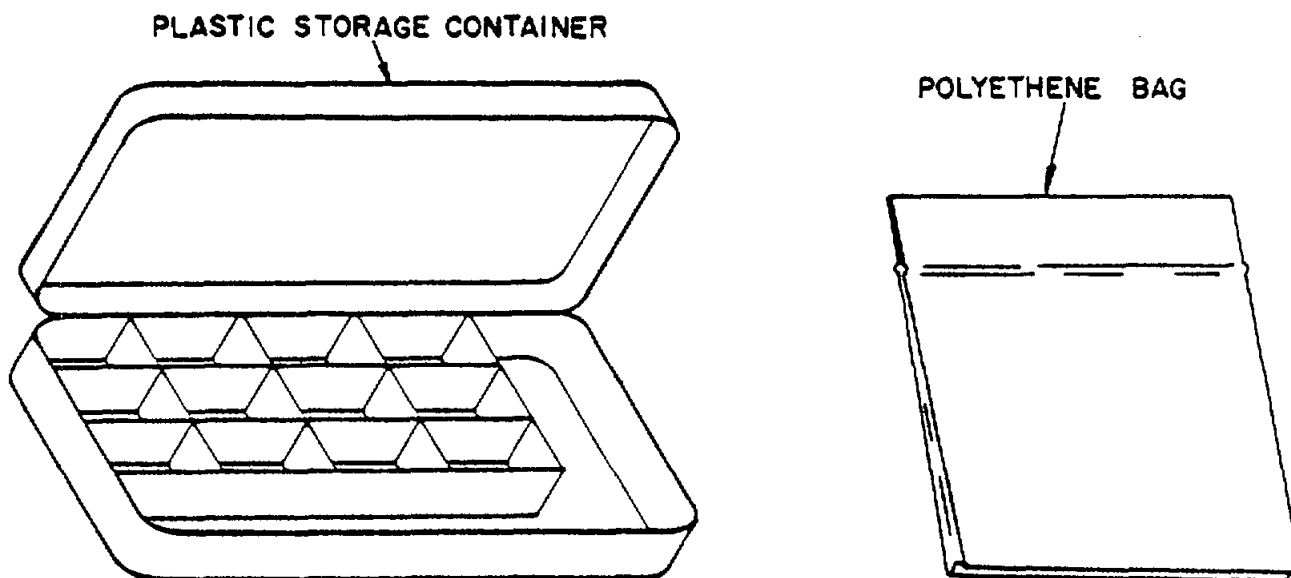

Figure 3-44. Storage Containers for loose parts

**Section VIII. USE OF PURGING AND CHARGING EQUIPMENT****3-17. General.**

This section contains general procedures for the setup of purging and charging equipment necessary to purge and charge fire control instruments. Refer to TM 750-116 (General Procedures For Purging and Charging Fire Control Instruments) for procedures on specific fire control instruments.

**3-18. Set Up of Purging and Charging Equipment (figs. 3-45 and 3-46).**

a. Set Up of Single Stage Pressure Test Fixture (fig. 3-45). Set up the single stage pressure test fixture as follows:

- (1) Obtain a tank (7) of dry nitrogen and remove threaded protective cover (6) from the outlet of the tank. Open tank valve (5) momentarily to rid valve seat of any foreign matter.

**WARNING**

**Do not drop tank of compressed nitrogen gas. When using in confined areas, use extreme care; gas could cause asphyxiation.**

- (2) Securely attach regulator (2) to tank valve (5) using appropriate adapter supplied with purging kit.

**NOTE**

**Two regulator assemblies are presently in use for purging and charging fire control materiel. The insert on figure 3-45 shows regulator 5580922 while the tank is shown with regulator 11729749.**

- (3) Securely attach hose assembly (8) to the adapter (9).

**NOTE**

**When using regulator 11729749, adapter 10917072-2 is required to connect hose assembly to low pressure port of regulator.**

- (4) Rotate pressure regulator valve (4) counterclockwise to the extreme closed position.
- (5) Open the nitrogen tank valve (5) slowly until the maximum tank pressure is registered on the high pressure gage (3).

**NOTE**

**If pressure indicated is less than 100 psig, obtain and use replacement tank.**

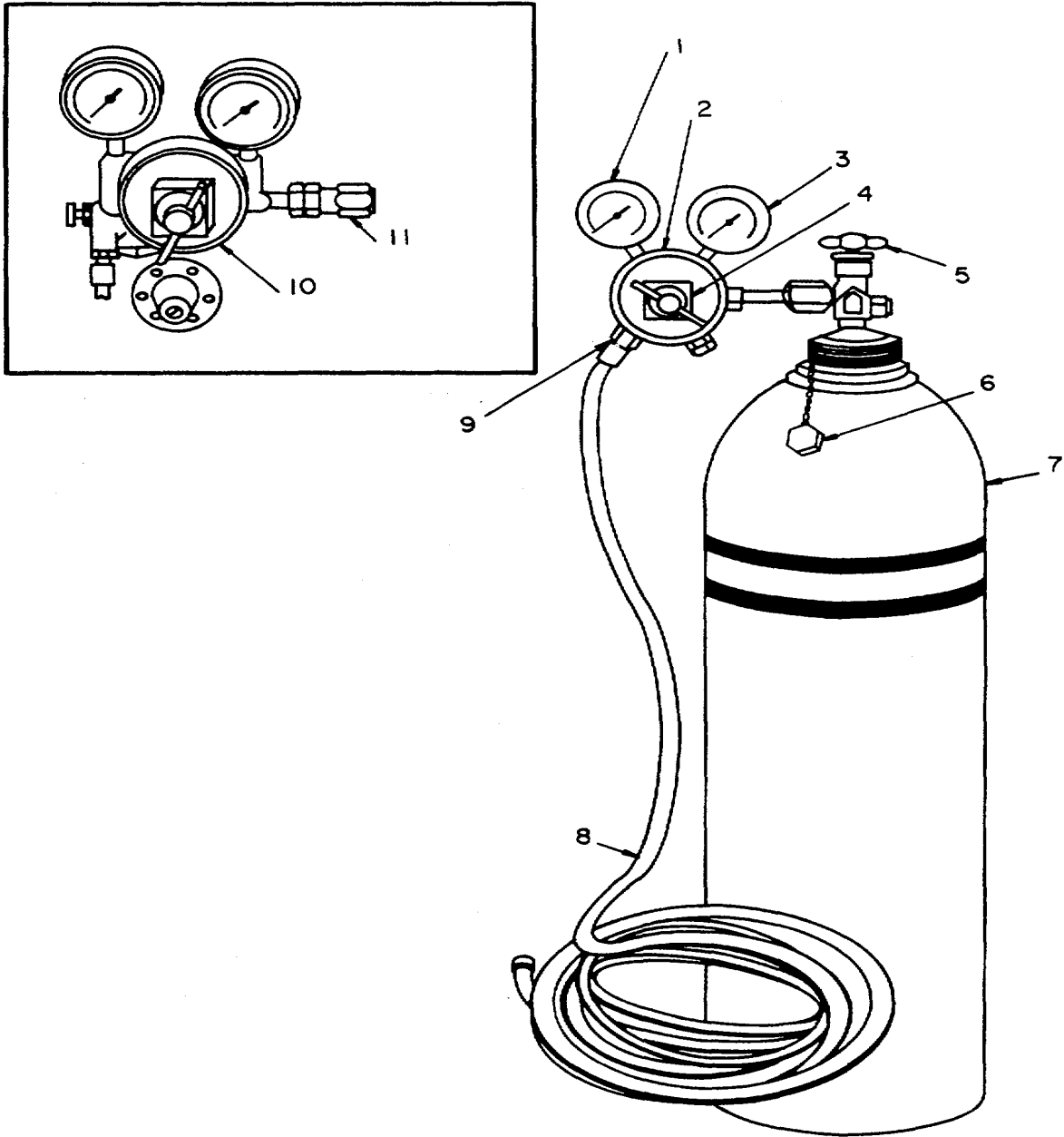

KEY to figure 3-45:

- |                             |                            |
|-----------------------------|----------------------------|
| 1. Low pressure gage        | 7. Technical nitrogen tank |
| 2. Regulator 11729749       | 8. Hose assembly           |
| 3. High pressure gage       | 9. Adapter                 |
| 4. Pressure regulator valve | 10. Regulator 5580922      |
| 5. Tank valve               | 11. Adapter 7680682        |
| 6. Protective cover         |                            |

Figure 3-45. Single Stage Pressure Test Fixture

**3-18. Set Up of Purging and Charging Equipment - Continued**

- (6) Slowly rotate pressure regulator valve (4) clockwise until approximately 5 psig is registered on the low pressure gage (1). Check for and eliminate any interference; close pressure regulator valve (4).

b. Set Up of Two Station Pressure Test Fixture (fig. 3-46). Set up the two station pressure test fixture as follows:

- (1) Place a tank of dry nitrogen (5) in a vertical position in the back of the fixture so that the tank is lodged in the structural steel "V" formation of the fixture and secure with the strap and clamping screw arrangement provided.
- (2) Secure pressure regulator (12) to the tank. Make certain pressure regulator valve (13) is turned counterclockwise to off. Open nitrogen tank valve (3) until maximum tank pressure is indicated on the high pressure gage (2).
- (3) Connect hose assembly (9) to regulator (12) and open manifold valve (10).

**CAUTION**

**At no time should the pressure be permitted to exceed 15 psig. Pressures greater than 15 psig could damage the unit.**

- (4) Open transfer valve (8) by pulling it to the outermost position.
- (5) Close test fixture valves (4), and insure low pressure gage (1) indicated 0 psig.
- (6) Open pressure regulator valves (13) until low pressure gage (1) indicates 15 psig.
- (7) Open test fixture valve (4) until test fixture gages (11) indicate(s) proper pressure.
- (8) Close manifold valve (10) and check pressure reading on test fixture gage (11).
- (9) Remove stopper (7) from outlet pipe (6). Open manifold valve (10) and check the pressure on test fixture gage (11). Adjust fixture valve (4) if necessary.
- (10) Close manifold valve (10) and attach feeder tube to outlet pipe (6).

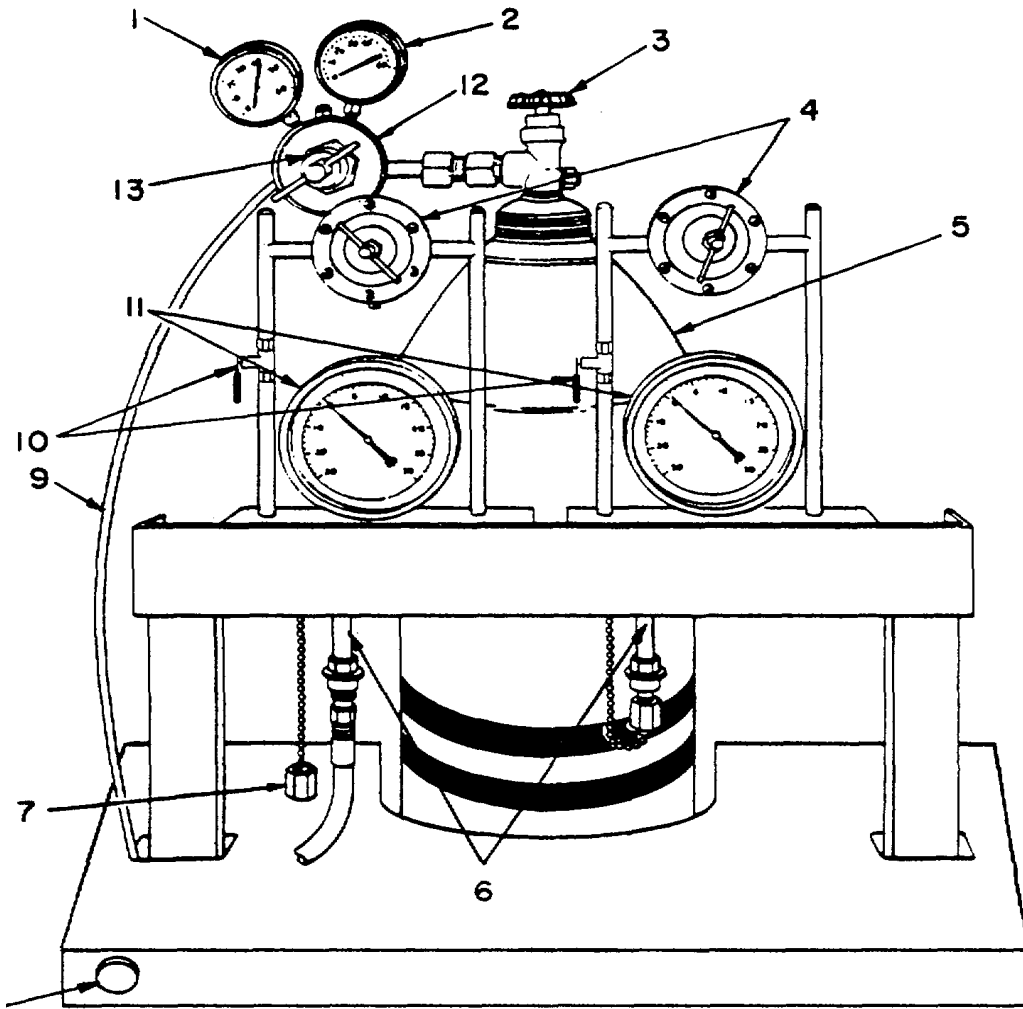

KEY to figure 3-46:

- |                       |                        |
|-----------------------|------------------------|
| 1. Low pressure gage  | 8. Transfer valve      |
| 2. High pressure gage | 9. Hose assembly       |
| 3. Tank valve         | 10. Manifold valve     |
| 4. Test fixture valve | 11. Test fixture gage  |
| 5. Nitrogen tank      | 12. Regulator assembly |
| 6. Outlet pipe        | 13. Regulator valve    |
| 7. Stopper            |                        |

Figure 3-46. Two Station Pressure Test Fixture

**3-19. Short Term Shutdown of Purging and Charging Equipment.**a. Short Term Shutdown for Single Stage Fixture (fig. 3-45).

- (1) With hose still connected to the purged unit, close tank valve (5) hand tight by turning clockwise.
- (2) Turn pressure regulator valve (4) counterclockwise until it moves easily in either direction. Pressure regulator valve is closed.
- (3) Loosen hose (8) connected at the purged unit. Let pressure on the low pressure gage (1) go to 0. Remove hose from purged unit.
- (4) Open pressure regulator valve (4) by turning clockwise. Gas will flow through the low pressure gage (1) and out the open end of hose (8).
- (5) When gas has been completely exhausted from the hose (8), both the low pressure gage (1) and the high pressure gage (3) will indicate 0. Close pressure regulator valve (4) by turning it counterclockwise until it moves easily in either direction.

b. Short Term Shutdown for a Two Station Pressure Test Fixture (fig. 3-46).

- (1) With the hose still connected to the purged unit, close tank valve (3) hand tight by turning clockwise.
- (2) Turn regulator valve (13) counterclockwise until it moves easily in either direction. Pressure regulator valve is closed.
- (3) Loosen feeder tube connected to the purged unit. Let pressure on the test fixture gage (11) go to 0. Remove feeder tube from purged unit.
- (4) Open regulator valve (13) by turning it clockwise. Gas will flow out the open end of the feeder tube.
- (5) When gas has been completely exhausted from the feeder tube, the test fixture gage (11), high pressure gage (2), and low pressure gage (1) will indicate 0. Close regulator valve (13) by turning it counterclockwise until it moves easily in either direction.
- (6) Close manifold valve (10) and disconnect feeder tube from outlet pipe (6) and block off outlet pipe with the stopper (7).

**3-20. Time Cycles.**

- a. Maintenance personnel will purge and charge fire control materiel every 90 days or when condensation is evident in the instrument.

**NOTE**

**The 90 day cycle does not apply to rangefinder end housings which are purged and charged once a year. However, a visual inspection is required every 90 days for evidence of moisture.**



### 3-20. Time Cycles - Continued

b. Maintenance personnel will purge and charge fire control materiel being repaired whenever the repair function affects internal sealing.

c. For maintenance of materiel in storage refer to TM 740-90-1 (Administrative Storage) and for time cycles refer to SB 740-95-601 (Storage Serviceability Standards for USAWECOM Materiel).

## Section IX. PURGING AND CHARGING FIRE CONTROL EQUIPMENT

### 3-21. General.

This section contains general procedures for purging and charging of fire control equipment. Insure that all preformed packings, gaskets, and seals have been properly installed into the instrument. Refer to the appropriate technical manual for a list of repair parts for the fire control instrument being repaired. Apply sealing compound to the threads of setscrews and air valve stem, around level vial mounting, and other places that may leak internal pressure while being leak tested. For the purpose of demonstration, the M118 series Elbow Telescope is used as the instrument being sealed and leak tested.

### 3-22. Purging and Charging.

- a. Purging (fig. 3-47). Purge the fire control instrument (M118 series Elbow Telescope) as follows:
- (1) Perform the setup of the single stage pressure test fixture as described in paragraph 3-18a.
  - (2) Remove the inlet port cap (3) and outlet screw (5).
  - (3) Attach the free end of the hose assembly (6) to the inlet port (4).
  - (4) Turn pressure regulator valve (2) clockwise until low pressure gage indicates 5 psig. Maintain pressure for 15 minutes.
  - (5) Turn pressure regulator valve (2) counterclockwise to off.
  - (6) Apply sealing compound to threads of outlet screw (5) and install.
- b. Charging (fig. 3-47). Charge the fire control instrument (M118 series Elbow Telescope) as follows:
- (1) Turn pressure regulator valve (2) clockwise until low pressure gage (1) indicates 1 psig. Maintain pressure for 1 minute.
  - (2) Turn pressure regulator valve (2) counterclockwise to off.
  - (3) Apply a soap solution to all sealed joints and screws.
  - (4) Observe the low pressure gage (1) and the telescope for 5 minutes minimum. If the pressure drops or bubbles appear, refer to the appropriate manual for maintenance procedures.
  - (5) Remove hose assembly (6) and install inlet port cap (3).

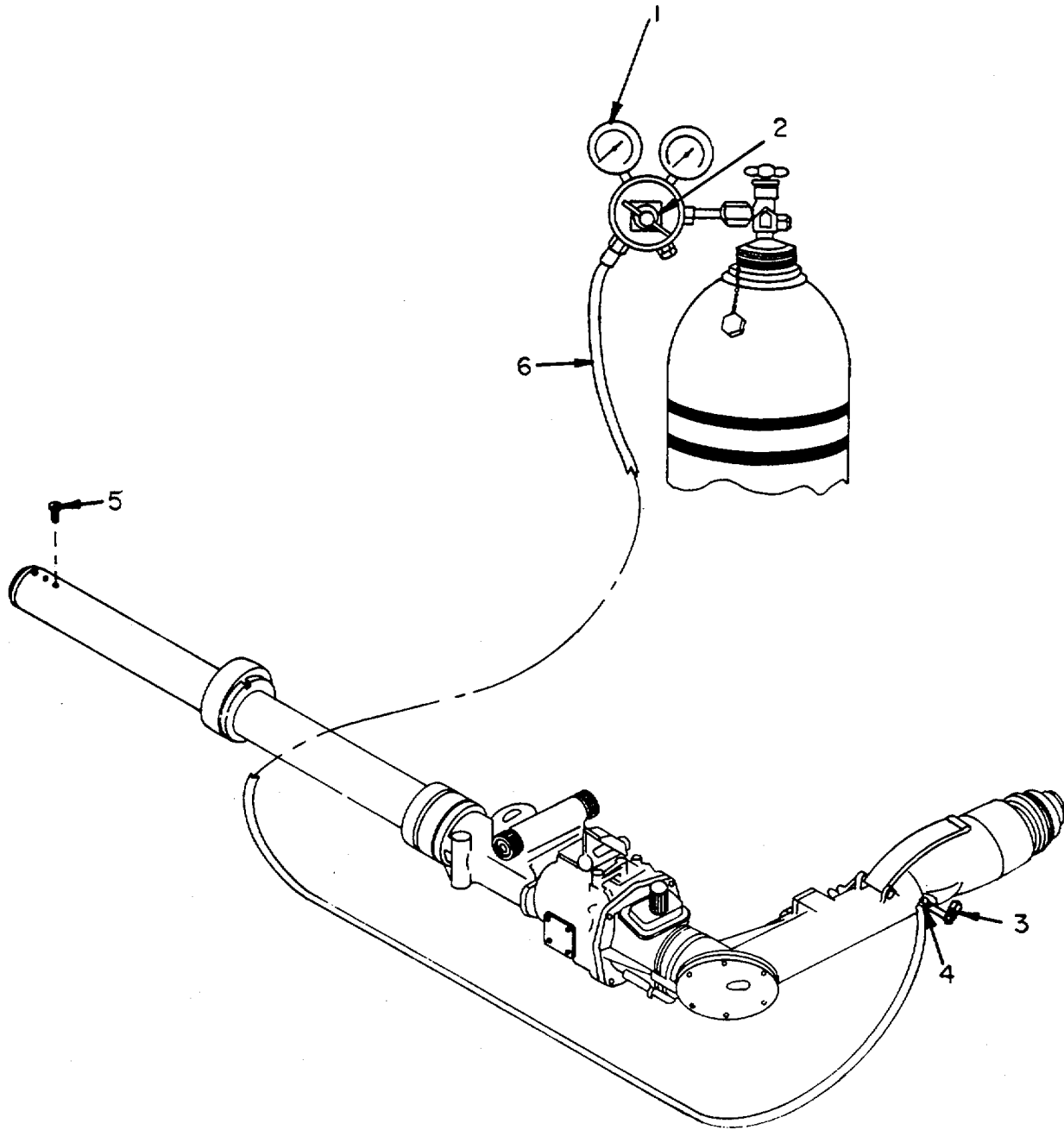

KEY to figure 3-47:

- |                             |                  |
|-----------------------------|------------------|
| 1. Low pressure gage        | 4. Inlet port    |
| 2. Pressure regulator valve | 5. Outlet screw  |
| 3. Inlet port cap           | 6. Hose assembly |

Figure 3-47. Purging and Charging M118 Series Elbow Telescope

**3-23. Level Assembly and Cover Assembly Leakage Test.**

a. Purpose of Test. To leak test level assemblies 11731291 or 10543755 and cover assembly 10543756 prior to installation on the elbow telescope. This procedure will help eliminate the possibility of the unit developing a leak during the over all leakage test of the elbow telescope.

b. Level Assembly 11731291 or 10543755. Perform the leakage test for the level assembly as follows:

**NOTE**

- o **Steps (2) through (7), refer to figure 3-48.**
- o **Insure that preformed packing is secured to bottom of level assembly before securing to fabricated adapter.**

- (1) Perform the setup of the single stage pressure test fixture as described in paragraph 3-18a.
- (2) Secure level assembly (7) to the fabricated leak test adapter (4) (fabricate per fig. C-1, appx C) with four machine screws (3) and four wing nuts (5).
- (3) Connect hose assembly (8) to the inlet port (6) on fabricated leak test adapter (4).
- (4) Adjust pressure regulator valve (2) clockwise until 1 psig is registered on the low pressure gage (1).
- (5) Maintain a 1 psig pressure for 10 seconds, then adjust pressure regulator valve (2) counterclockwise to the closed position.
- (6) Disconnect hose assembly (8) from the inlet port (6) and lay hose assembly aside.

**NOTE****Steps (7) through (9), refer to figure 3-49.**

- (7) Completely immerse the level assembly (5) and fabricated leak test adapter (3) into a container of clear water (1).
- (8) While immersed, inspect the areas around the level vial (4) and lamp shell (2) for the presence of air bubbles that indicate pressure leaks.
- (9) Remove level assembly (5) and fabricated leak test adapter (3) from the container of clear water (1).

**NOTE****Steps (10) through (12), refer to figure 3-48.**

- (10) Release pressure from fabricated leak test adapter (4) at inlet port (6).

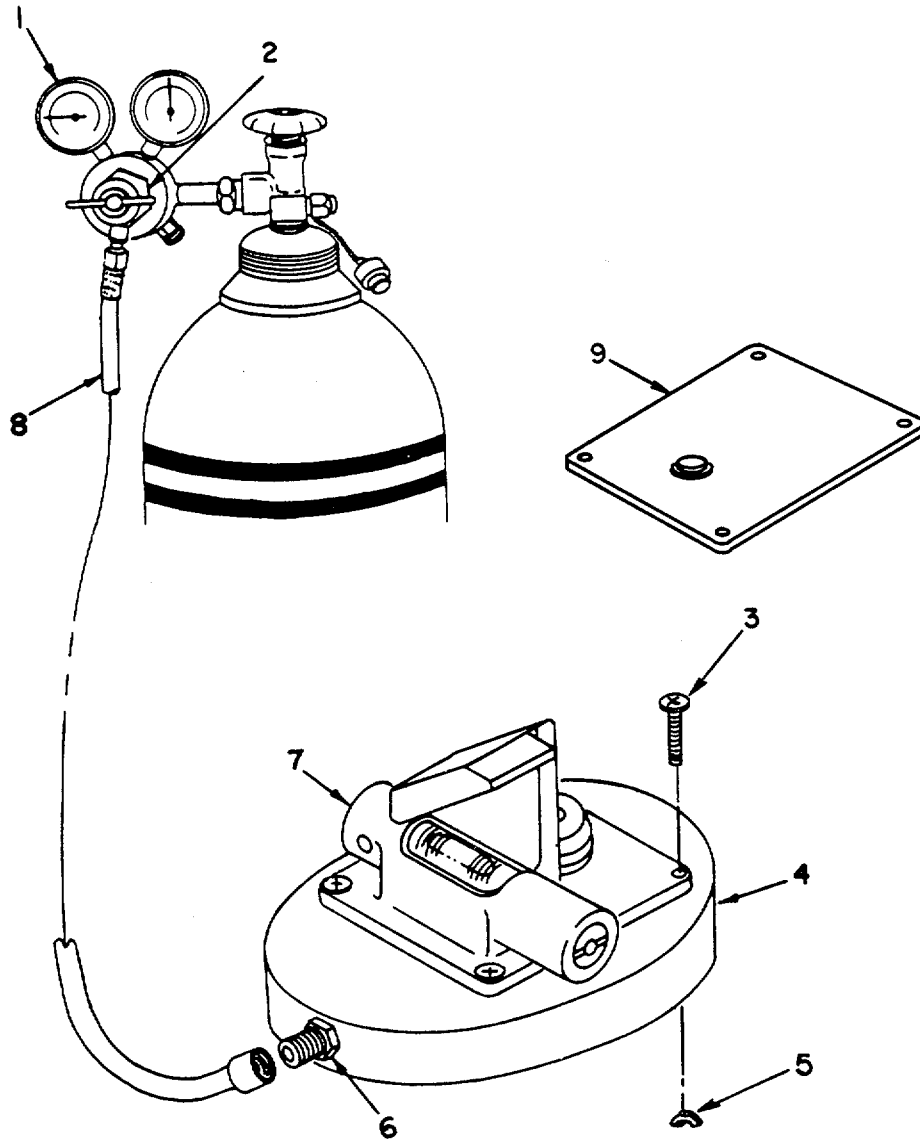

**NOTE:** SECURE COVER ASSEMBLY TO LEAK TEST ADAPTER IN THE SAME MANNER AS THE LEVEL ASSEMBLY.

KEY to figure 3-48:

- |                                 |                   |
|---------------------------------|-------------------|
| 1. Low pressure gage            | 6. Inlet port     |
| 2. Pressure regulator valve     | 7. Level assembly |
| 3. Machine screw (4)            | 8. Hose assembly  |
| 4. Fabricated leak test adapter | 9. Cover assembly |
| 5. Wing nut (4)                 |                   |

Figure 3-48. Pressurizing Level Assembly

## 3-23. Level Assembly and Cover Assembly Leakage Test - Continued

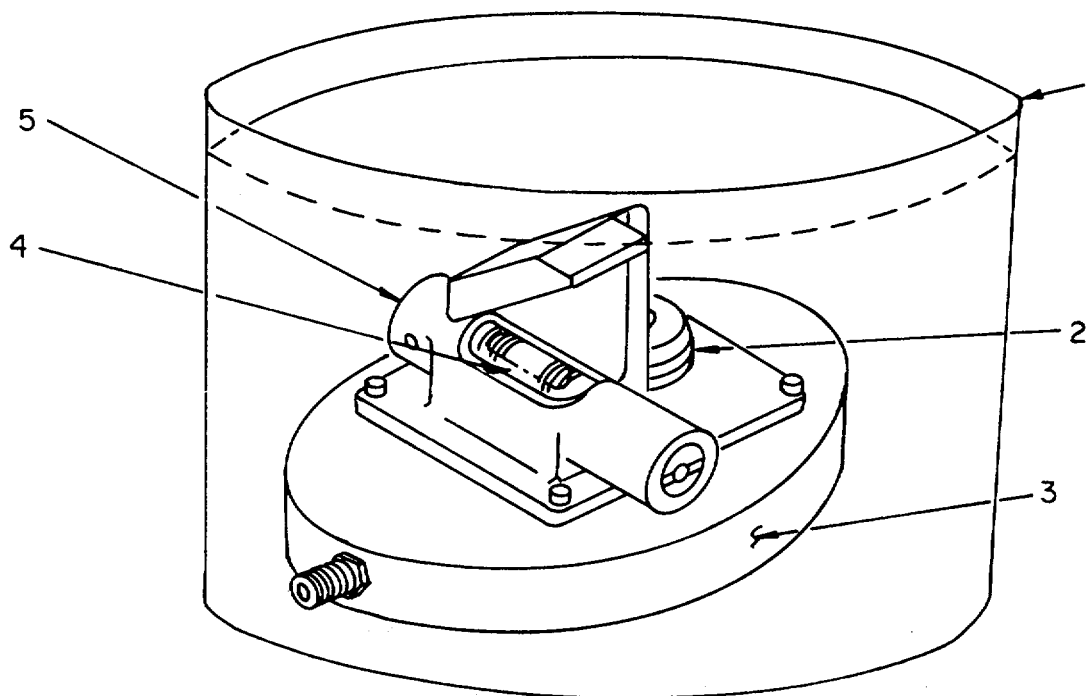

KEY to figure 3-49:

- |                                 |                   |
|---------------------------------|-------------------|
| 1. Container of clear water     | 4. Level vial     |
| 2. Lamp shell                   | 5. Level assembly |
| 3. Fabricated leak test adapter |                   |

*Figure 3-49. Leak Testing Level Assembly*

- (11) Remove four wing nuts (5), four machine screws (3), and level assembly (7) from fabricated leak test adapter (4).
- (12) If air bubbles were detected, repair level assembly as required and repeat the level assembly leakage test.
- (13) If air bubbles were not detected, use a clean, dry cloth to dry level assembly.

**3-23. Level Assembly and Cover Assembly Leakage Test - Continued**

c. Cover Assembly 10543756. Perform leakage test of cover assembly as follows:

**NOTE**

- o **Steps (2) through (7), refer to figure 3-48.**
- o **Insure that preformed packing is secured to bottom of cover assembly before securing to the fabricated adapter.**

- (1) Perform the setup of the single stage pressure test fixture as described in paragraph 3-18a.
- (2) Secure cover assembly (9) to the fabricated leak test adapter (4) with four machine screws (3) and four wing nuts (5).
- (3) Connect hose assembly (8) to the inlet port (6) on fabricated leak test adapter (4).
- (4) Adjust pressure regulator valve (2) clockwise until 1 psig is registered on the low pressure gage (1).
- (5) Maintain a 1 psig pressure for 10 seconds, then adjust pressure regulator valve (2) counterclockwise to the closed position.
- (6) Disconnect hose assembly (8) from the inlet port (6) and lay hose assembly aside.

**NOTE****Steps (7) through (9), refer to figure 3-50.**

- (7) Completely immerse the cover assembly (2) and fabricated leak test adapter (3) into a container of clear water (1).
- (8) While immersed, inspect the area around the lamp shell (4) for the presence of air bubbles that indicates a pressure leak.
- (9) Remove cover assembly (2) and fabricated leak test adapter (3) from the container of clear water (1).

**NOTE****Steps (10) through (12), refer to figure 3-48.**

- (10) Release pressure from fabricated leak test adapter (4) at inlet port (6).

## 3-23. Level Assembly and Cover Assembly Leakage Test - Continued

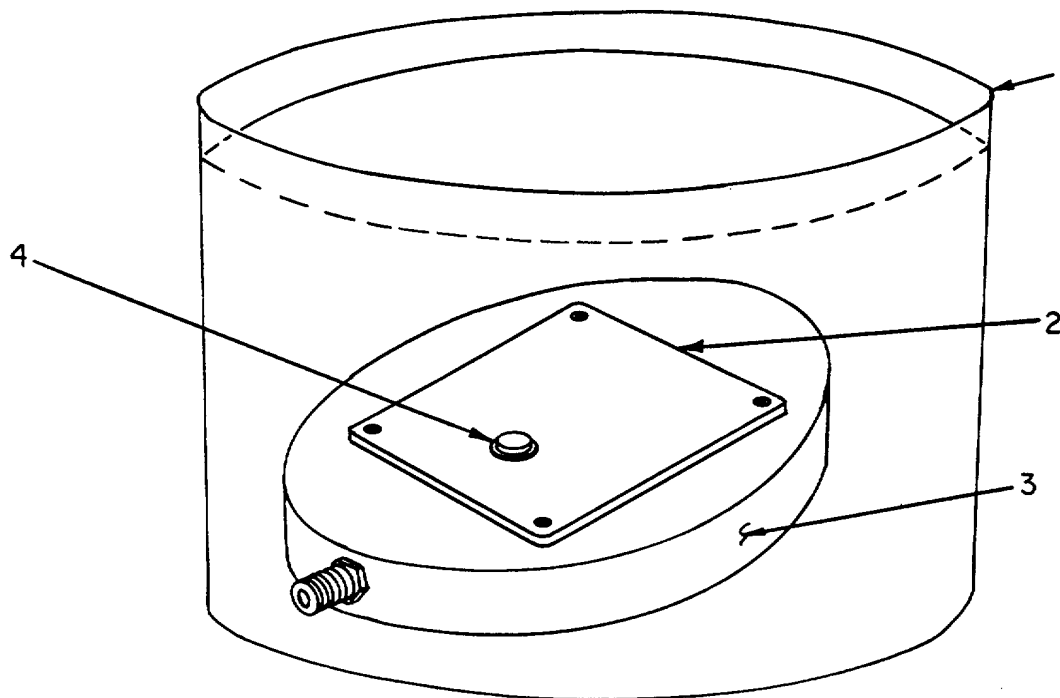

KEY to figure 3-50:

- |                             |                                 |
|-----------------------------|---------------------------------|
| 1. Container of clear water | 3. Fabricated leak test adapter |
| 2. Cover assembly           | 4. Lamp shell                   |

*Figure 3-50. Leak Testing Cover Assembly*

- (11) Remove four wing nuts (5), four machine screws (3), and cover assembly (9) from fabricated leak test adapter (4).
- (12) If air bubbles were detected, repair cover assembly as required and repeat the cover assembly leakage test.
- (13) If air bubbles were not detected, use a clean, dry cloth to dry cover assembly.

**CHAPTER 4**  
**HAND TOOLS**

**Section I. USE AND CARE OF HAND TOOLS**

**4-1. Torque Wrench.**

a. General. The term torque as applied to hand tools that measure a turning force is actually incorrect. "Torque measuring" or "torque indicating" would be more descriptive since all tools used to turn or twist are involved with torque. A simple screwdriver or wrench could be called a torque tool. Torque is a turning or twisting force distinctly different from tension which is a straight pull.

b. Determining Torque (fig. 4-1). Simple leverage is the same as torque and both are measured in terms of force and distance (distance is the length of the lever, force is the amount of pulling or pushing applied at the end of the lever). Example: length of the lever is 10 inches, pulling pressure applied is 6 pounds.

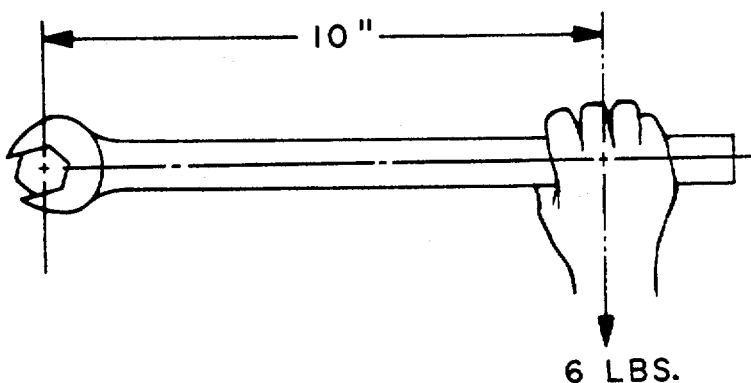

*Figure 4-1. Torque Computation*

(1) Let: T = Torque (inch-pounds, inch-ounces, foot-pounds, etc.)

F = Force (pounds or ounces)

L = Length of lever arm (inches, feet)

$L \times F = T$

10 inches x 6 pounds = 60 inch-pounds



#### 4-1. Torque Wrench - Continued

- (2) Since it is known that distance times force will give us the torque of a given application it is a simple matter to turn the formula around and build a tool for a known torque requirement (fig. 4-2). Using the same example and knowing only the torque requirements of a tool: 60 inch-pounds =  $L \times F$

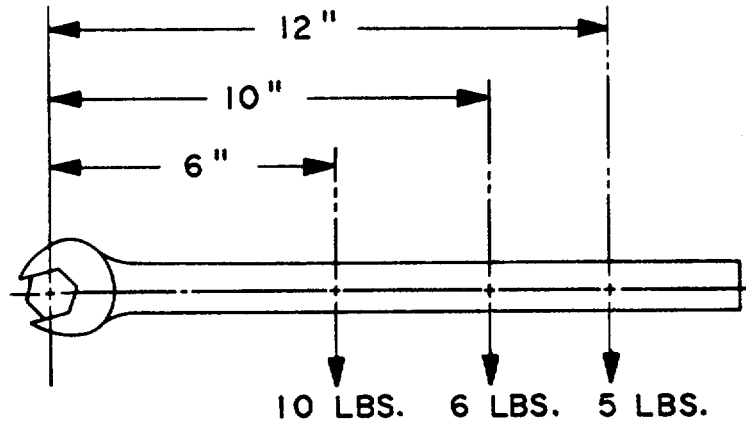

Figure 4-2. Length vs Force - Torque

- (3) We know that the tool can have a leverage of 10 inches with a 6 pound pull, 12 inches with a 5 pound pull, or even 6 inches with a 10 pound pull. The tool can be built to fit the application whether a long or short lever is required, a curved lever to fit a hard-to-reach fastener, a self-contained tool or one that will take many adapters or accessories.

- c. Use of a Torque Wrench (fig. 4-3). A torque wrench must be used when manuals call out torque on a nut or bolt.

#### CAUTION

**Do not use a torque wrench to loosen nuts or bolts. This will damage the wrench.**

- (1) Threads should be clean, free of burrs, and lubricated before torquing. Use a little light lubricating oil or anti-seize compound.

#### NOTE

**Use a wrench to make sure bolt or nut is snug. Then use the torque wrench.**

- (2) When torquing, the hand should be in center of handle (1) as shown and not too far in (2), or too far out (3).

4-1. Torque Wrench - Continued

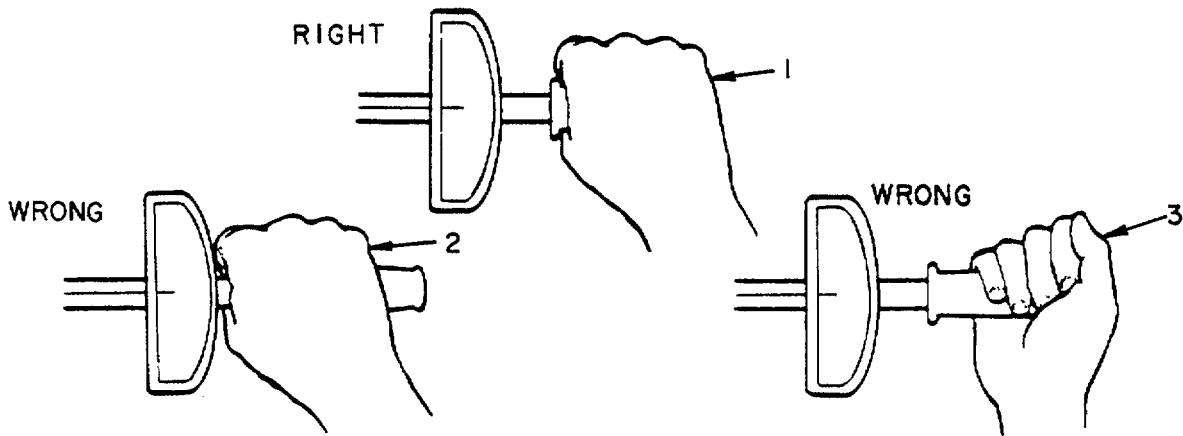

Figure 4-3. Torque Wrench - Hand Position

**NOTE**

In steps (3) through (7) refer to figure 4-4.

- (3) Place correct size socket (1) on bolt head or nut (2), begin by turning wrench handle (3) clockwise for a right-hand bolt (standard).
- (4) When bolt head (2) or nut begins to feel tight, turning force on handle (3) will start to flex or bend beam (4). Pointer (5) is supported only at drive end (6) of wrench and therefore will not bend with beam.
- (5) Scale (7) is fastened to beam (4) near handle (3). As beam bends, scale (7) will move with beam (4) under pointer (5) so that pointer indicates numbers away from 0.
- (6) Watching pointer (5), slowly and smoothly continue tightening bolt head (2) or nut until pointer (5) indicates the correct amount of torque on scale (7).
- (7) When pointer (5) indicates the correct torque on scale (7) slowly release pressure on handle (3).

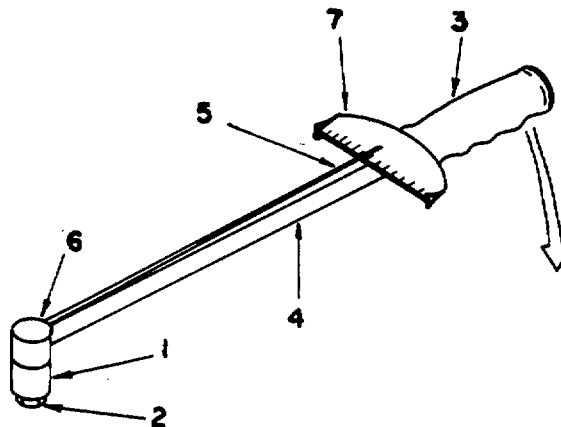

Figure 4-4. Torque Wrench - Illustrated Use

4-1. Torque Wrench - Continued

d. Adapter Length Compensation (figs. 4-5 and 4-6). When adapters are used that rotate about a center not located at the center of the tang of the torque wrench, it is necessary to compensate for the additional length. An extension will always increase the capacity of the wrench.

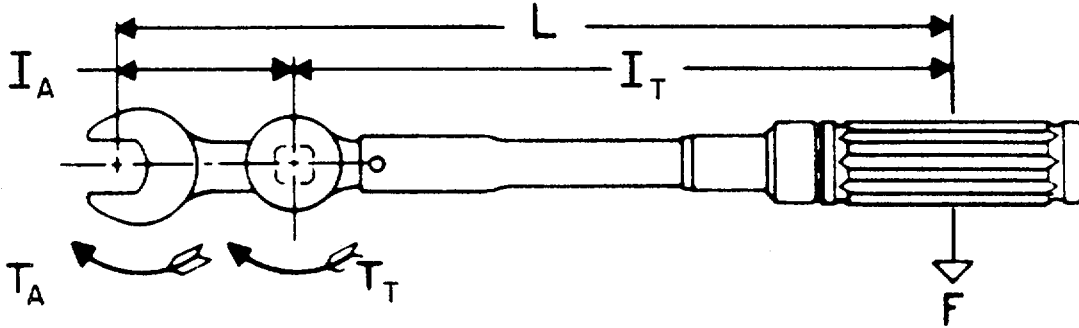

Figure 4-5. Torque Wrench - Straight Extension

(1) When an extension adapter is used as shown in figure 4-5.

Let:  $F$  = Force (pounds)

$I_T$  = Wrench length (inches) measured from the middle of handle to the center of the tang.

$I_A$  = Extension length (inches) measured from center of socket to center of drive square.

$L$  = Effective lever length

$$L = I_T + I_A$$

Example: (figure 4-5)

Assuming that the length of the torque wrench being used is 12 inches. The length of the extension is 2 inches. The torque setting of the wrench is 60 in. lbs.. The total torque applied at extension is 70 in. lbs.

Equation

$$T_A = \frac{T_T \times L}{I_T} \text{ or } T_A = \frac{60 \times 14}{12} \text{ or } T_A = 70 \text{ in. lbs.}$$

Where:  $T_A$  = Torque applied at extension

$$L = I_T (12 \text{ inches}) + I_A (2 \text{ inches})$$

$T_T$  = Setting of torque wrench (60 in. lbs.)

$I_T$  = Wrench length (12 inches)

4-1. Torque Wrench - Continued

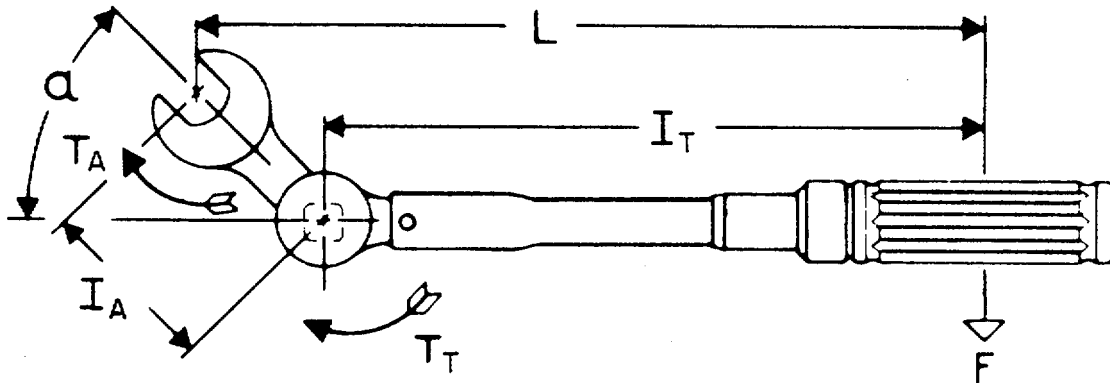

Figure 4-6. Torque Wrench - Angled Extension

(2) When an extension adapter is used as shown in figure 4-6.

Let: F = Force (pounds)

$I_T$  = Wrench length (inches) measured from the middle of handle to the center of the tang

$I_A$  = Extension length (inches) measured from center of socket to center of drive square

L = Effective lever length

$L = I_T \times I_A \cos a$  (or measure as shown)

(3) To find torque setting ( $T_T$ ) when desired amount of torque exerted at extension ( $T_A$ ) is known.

EQUATION

$$T_T = \frac{T_A \times I_T}{L}$$

(4) To find torque exerted at extension for a particular torque setting.

EQUATION

$$T_A = \frac{T_T \times L}{I_T}$$

e. Torque Unit Conversion. When checking the specified torque of a bolt, it may be necessary, because of the torque wrench calibration, to convert torque units from one to another (foot-pounds to inch-ounces). This can be done readily using table 4-1.

4-1. Torque Wrench - Continued

Table 4-1. Torque Unit Conversion

Inch-grams	Inch-ounces	Inch-pounds	Foot-pounds	Centimeter kilograms	Meter kilograms
7.09	0.25				
14.17	0.5				
21.26	0.75				
28.35	1.				
113.4	4.	0.25			
226.8	8.	0.5			
453.6	16.	1.	0.08	1.11	
	32.	2.	0.17	2.35	
	48.	3.	0.25	3.46	
	64.	4.	0.33	4.56	
	80.	5.	0.42	5.81	
	96	6.	0.5	6.91	
	112.	7.	0.58	8.02	
	128.	8.	0.67	9.26	
	144.	9.	0.75	10.37	
	160.	10.	0.83	11.48	
	192.	12.	1.	13.83	0.138
	240.	15.	1.25	17.28	0.173
	320.	20.	1.67	23.09	0.231
	384.	24.	2.	27.65	0.277
	400.	25.	2.08	28.76	0.288
	576.	36.	3.	41.48	0.415
	768.	48.	4.	55.30	0.553
	800.	50.	4.16	57.52	0.575
	960.	60.	5.	69.13	0.691
		72.	6.	82.95	0.830
		84.	7.	96.78	0.968
		96.	8.	110.61	1.106
		100.	8.33	115.17	1.152
		108.	9.	124.43	1.244
		120.	10.	138.26	1.383
		180.	15.	207.39	2.074
		200.	16.66	230.34	2.303
		240.	20.	276.51	2.765
		300.	25.	345.64	3.456
		500.	41.65	575.84	5.758
		600.	50.	691.29	6.913
		1000.	83.33	1151.68	11.517
		1200.	100.	1382.57	13.626
		2000.	166.6	2303.37	23.034
		2400.	200.	2765.15	27.651
		5000.	416.5	5758.42	57.584
		6000.	500.	6912.86	69.129
		12000.	1000.	13825.73	138.257
		24000.	2000.	27651.46	276.515

4-1. Torque Wrench - Continued

Table 4-1.1. Torque Value Guide - Pound Feet

Screw Diameter		Torque LB-FT No Dashes (SAE Grade 2)	Torque LB-FT 3 Dashes (SAE Grade 5)	Torque LB-FT 6 Dashes (SAE Grade 8)	Socket Size
1/4 - 20	UNC	3 - 5	6 - 8	10 - 12	7/16
1/4 - 28	UNF	4 - 6	8 - 10	9 - 14	7/16
5/16 - 18	UNC	7 - 11	13 - 17	19 - 24	1/2
5/16 - 24	UNF	7 - 11	14 - 19	23 - 28	1/2
3/8 - 16	UNC	14 - 18	26 - 31	39 - 44	9/16
3/8 - 24	UNF	15 - 19	30 - 35	46 - 51	9/16
7/16 - 14	UNC	23 - 28	44 - 49	65 - 70	5/8
7/16 - 20	UNF	23 - 28	44 - 54	69 - 79	5/8
1/2 - 13	UNC	32 - 37	65 - 75	95 - 105	3/4
1/2 - 20	UNF	34 - 41	73 - 83	113 - 123	3/4
9/16 - 12	UNC	46 - 56	100 - 110	145 - 155	13/16
9/16 - 18	UNF	47 - 57	107 - 117	165 - 175	13/16
5/8 - 11	UNC	62 - 72	140 - 150	200 - 210	15/16
5/8 - 18	UNF	67 - 77	153 - 163	235 - 245	15/16
3/4 - 10	UNC	106 - 116	200 - 270	365 - 375	1 1/4
3/4 - 16	UNF	115 - 125	268 - 278	417 - 427	1 1/4
7/8 - 9	UNC	165 - 175	385 - 395	595 - 605	1 5/16
7/8 - 14	UNF	178 - 188	424 - 434	663 - 673	1 5/16
1 - 8	UNC	251 - 261	580 - 590	900 - 910	1 1/2
1 - 14	UNF	255 - 265	585 - 634	943 - 993	1 1/2
1 1/4 - 7	UNC	541 - 461	1070 - 1120	1767 - 1817	1 7/8
1 1/4 - 12	UNF	488 - 498	1211 - 1261	1963 - 2013	1 7/8
1 1/2 - 6	UNC	727 - 737	1899 - 1949	3111 - 3161	2 1/4
1 1/2 - 12	UNF	816 - 826	2144 - 2194	3506 - 3556	2 1/4

4-1. Torque Wrench - Continued

Table 4-1.2. Torque Value Guide - Newton-Meters

Screw Diameter		Torque Nm No Dashes (SAE Grade 2)	Torque Nm 3 Dashes (SAE Grade 5)	Torque Nm 6 Dashes (SAE Grade 8)	Socket Size
1/4 - 20	UNC	4 - 7	8 - 11	14 - 6	7/16
1/4 - 28	UNF	5 - 8	11 - 14	12 - 19	7/16
5/16 - 18	UNC	9 - 15	18 - 23	26 - 33	1/2
5/16 - 24	UNF	9 - 15	19 - 26	31 - 38	1/2
3/8 - 16	UNC	19 - 24	35 - 42	53 - 60	9/16
3/8 - 24	UNF	20 - 26	41 - 47	62 - 69	9/16
7/16 - 14	UNC	31 - 38	60 - 66	88 - 95	5/8
7/16 - 20	UNF	31 - 38	60 - 73	94 - 107	5/8
1/2 - 13	UNC	43 - 50	88 - 102	129 - 142	3/4
1/2 - 20	UNF	46 - 56	99 - 113	153 - 167	3/4
9/16 - 12	UNC	62 - 76	136 - 149	197 - 210	13/16
9/16 - 18	UNF	64 - 77	145 - 159	224 - 237	13/16
5/8 - 11	UNC	84 - 98	190 - 203	271 - 285	15/16
5/8 - 18	UNF	91 - 104	207 - 221	319 - 332	15/16
3/4 - 10	UNC	144 - 157	353 - 366	495 - 508	1 1/4
3/4 - 16	UNF	156 - 169	363 - 377	565 - 579	1 1/4
7/8 - 9	UNC	224 - 237	522 - 536	807 - 820	1 5/16
7/8 - 14	UNF	241 - 255	575 - 588	899 - 912	1 5/16
1 - 8	UNC	340 - 354	786 - 800	1220 - 1234	1 1/2
1 - 14	UNF	346 - 359	793 - 860	1279 - 1346	1 1/2
1 1/4 - 7	UNC	611 - 625	1451 - 1518	2396 - 2463	1 7/8
1 1/4 - 12	UNF	662 - 675	1642 - 1710	2661 - 2729	1 7/8
1 1/2 - 6	UNC	986 - 999	2575 - 2642	4218 - 4286	2 1/4
1 1/2 - 12	UNF	1106 - 1120	2907 - 2975	4753 - 4821	2 1/4

## 4-2. Use of Gages.

a. General. This section contains general information about micrometers and feeler gages. A more detailed explanation concerning use and operation of these and other types of gages is contained in TM 9-243, Use and Care of Handtools and Measuring Tools.

b. Micrometer (fig. 4-7). Micrometers are used for measurements requiring precise accuracy. The micrometer screw (3) has a pitch of 40 threads to the inch; in other words, if a screw is turned forty times, it moves the spindle (2) exactly 1 inch either towards or away from the anvil (1). A clockwise turn moves the spindle toward the anvil. A counterclockwise turn moves the spindle away from the anvil or opens the micrometer.

- (1) The revolution line along the barrel (10) illustrated in (fig. 4-8), is 1 inch long and is divided into ten equal parts, indicated by numbered graduations. The unnumbered graduations in turn divide each numbered graduation into four equal parts.
- (2) Assume that the thimble is turned counterclockwise from completely closed position until the first numbered graduation is reached. The thimble will have turned four full revolutions and moved a distance of 0.100 inch (1/10 inch). Each unnumbered graduation is 0.025 of an inch along the revolution line. Each complete revolution of the thimble moves it this distance.

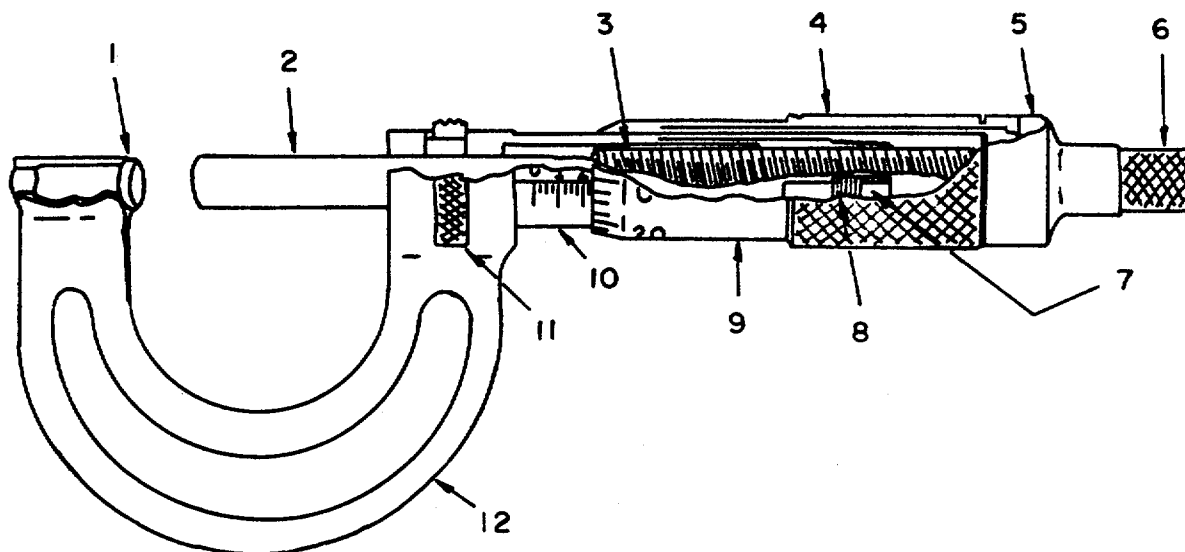

KEY to figure 4-7:

- |                     |                   |
|---------------------|-------------------|
| 1. Anvil            | 7. Adjustment nut |
| 2. Spindle          | 8. Slotted nut    |
| 3. Micrometer screw | 9. Thimble        |
| 4. Thimble sleeve   | 10. Barrel        |
| 5. Thimble cap      | 11. Clamp ring    |
| 6. Ratchet stop     | 12. Frame         |

Figure 4-7. Micrometer Caliper - Cutaway View



4-2. Use of Gages - Continued

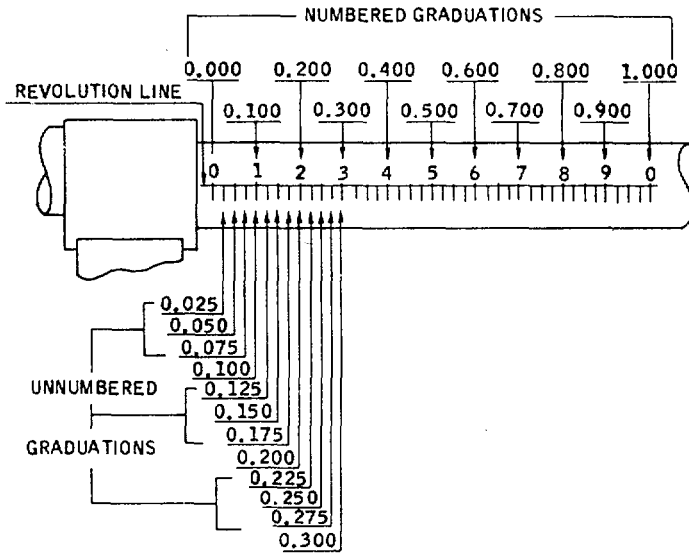

Figure 4-8. Micrometer Barrel

- (3) The graduations on the thimble illustrated below, (fig. 4-9), further divide the indications into single thousandths of an inch by indicating each twenty-fifth of a revolution of the thimble. Therefore one twenty-fifth of a revolution of the thimble opens or closes the micrometer 0.001 inch (1/1000 inch). When the micrometer is in the fully closed position, the edge of the thimble coincides with 0 on the barrel, and 0 on the thimble coincides with the revolution line. Each time a graduation on the thimble passes the revolution line on the barrel, the micrometer opens 0.001 inch.

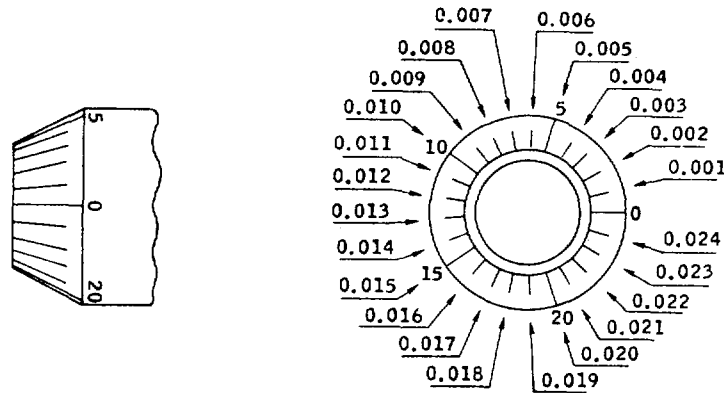

Figure 4-9. Graduated End of Thimble

4-2. Use of Gages - Continued

- (4) The following is a recommended procedure for obtaining a correct reading on the micrometer barrel.
  - (a) Find the largest number graduation on the revolution line between 0 and the edge of the thimble.
  - (b) Find the number of unnumbered graduations between the largest numbered graduation and the edge of the thimble.
  - (c) Find the number of graduations on the thimble, taking careful note of 0 on the thimble in relation to the revolution line on the barrel.

Example 1: (fig. 4-10)

The thimble has been turned counterclockwise through twelve complete revolutions and the edge of the thimble is directly over the third numbered graduation on the barrel. The 0 on the thimble is directly over or coincides with the revolution line on the barrel. The correct reading in this particular instance is 0.300 inch.

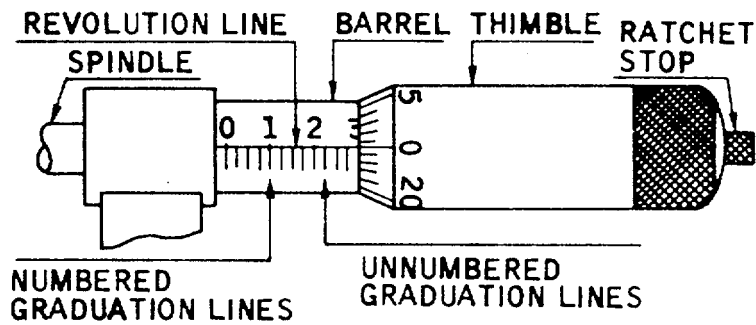

Figure 4-10. Micrometer Barrel Setting - .300 inch

4-2. Use of Gages - Continued

Example 2: (fig. 4-11)

The largest numbered graduation on the barrel is 1. There are two unmarked graduations to the right of 1. The graduation on the thimble coinciding with the revolution line is 22.

0.100 inch - Largest number on revolution line between 0 and the edge of the thimble.

0.050 inch - The sum of the two unmarked graduations between 1 and the edge of the thimble (each unnumbered graduation represents 0.025 inch).

0.022 inch - Number of the graduations on the thimble coinciding with the revolution line.

0.172 inch - The correct final reading. Example 3: (fig. 4-12)

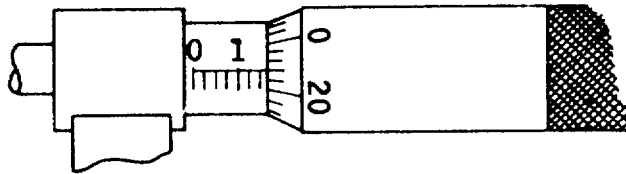

Figure 4-11. Micrometer Barrel Setting - .172 inch

0.300 inch - Largest number on the revolution line between 0 and the edge of the thimble.

0.025 inch - One unmarked graduation between 3 and the edge of the thimble.

0.001 inch - Number of the graduation on the thimble between 0 on the thimble and the revolution line.

0.326 inch - The correct final reading. If the 0 on the thimble coincided with the revolution line, the correct reading would be 0.325 inch; if the 0 were but one graduation above the revolution line, the correct reading would be 0.324 inch.

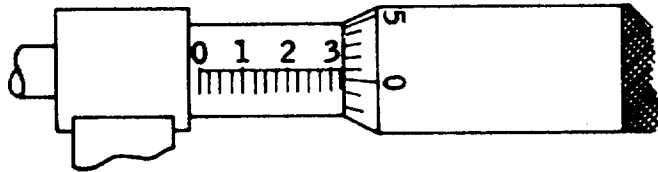

Figure 4-12. Micrometer Barrel Setting - .326 inch

4-2. Use of Gages - Continued

Example 4:(fig. 4-13)

0.500 inch - Largest numbered graduation on the revolution line.

0.000 inch - Number of unmarked graduations between 5 and the edge of the thimble.

0.004 inch - Number of graduations between 0 on the thimble and the revolution line.

0.504 inch - The final correct reading. In this example the edge of the thimble appears to coincide with the 0.500 graduation on the barrel. If this were true the 0 line on the thimble would coincide with the revolution line; hence, the last figure of the final reading cannot be 0.

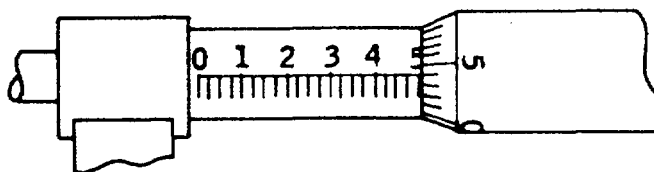

Figure 4-13. Micrometer Barrel Setting - .504 inch

c. Thickness Gage (fig. 4-14). The thickness gage, often referred to as a feeler gage, measures the clearance or distance of separation between two surfaces that face each other.

- (1) The thickness gage contains several blades, each blade calibrated to a known thickness in thousandths of an inch or in millimeters for metric sizes. Each of the blades is of a different thickness and each blade has its thickness printed on the blade itself.

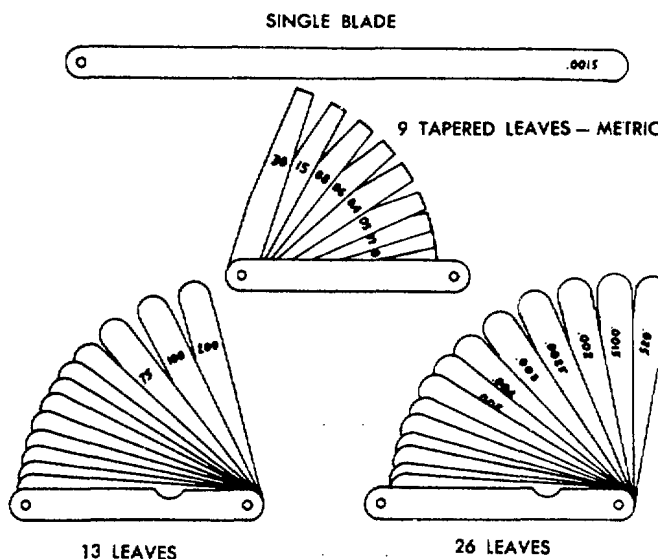

Figure 4-14. Thickness Gage - Blade Type

#### 4-2. Use of Gages - Continued

- (2) The following is a recommended procedure for obtaining a correct reading when using a thickness gage.
- (a) Estimate the thickness needed to fill the space being measured.
  - (b) Choose several thicknesses of blades to fill the space being measured.
  - (c) Turn the blades so that they are stacked together and try to insert stacked blades into space being measured.

#### CAUTION

**Do not force blades into space at any time. Forcing blades may damage either the blades themselves or the surfaces of material being measured.**

- (d) If stacked blades are too thick to fit into space, fold back thick blades one at a time and substitute thin blades in place of the thick blades.
- (e) If stacked blades do not fill the space, add blades or substitute blades until you form a snug fit between surfaces being measured.
- (f) Remove blades, read thickness of each, and add the numbers together.

#### NOTE

**Item numbers below refer to figure 4-15, unless otherwise indicated.**

Example:

One of the uses of a thickness gage is to measure the gap (1) needed between the traverse lock assembly and the turret ring.

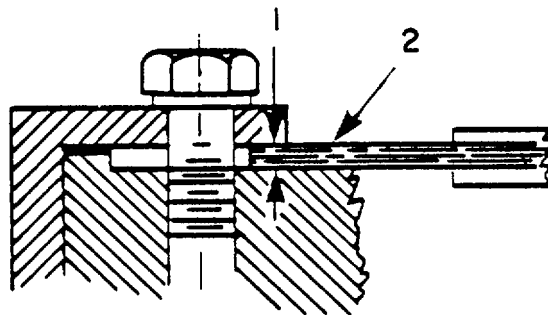

Figure 4-15. Traverse Lock Assembly

#### 4-2. Use of Gages - Continued

Look at the space to be measured (1) and estimate the thickness needed to fill the space, (approximately .035 inch).

#### CAUTION

**Do not force blades into space at any time. Forcing blades may damage the gage or the surfaces of the material being measured.**

Choose several thick blades to fill the space, (for instance  $.020 + .010 + .005$ ). Turn the blades so they are all stacked together and try to insert the blades (2) into the space to be measured (1). If stacked blades are too thick to fit into space to be measured (1) remove gage.

Fold back a thick blade and insert thinner blades in place of the thick blade. Continue to measure the space between the two surfaces until a snug fit is obtained.

If the blades of the thickness gage (2) do not fill the space being measured, add blades or substitute thicker blades until you have a snug fit.

Remove the blades of the thickness gage and read the thickness of each, add the numbers together.

In this example (fig. 4-16), the thickness of each blade used to measure the space is:  $.020 + .010 + .002 + .0015 + .001 = .0345$ . Rounded off to .035 inch.

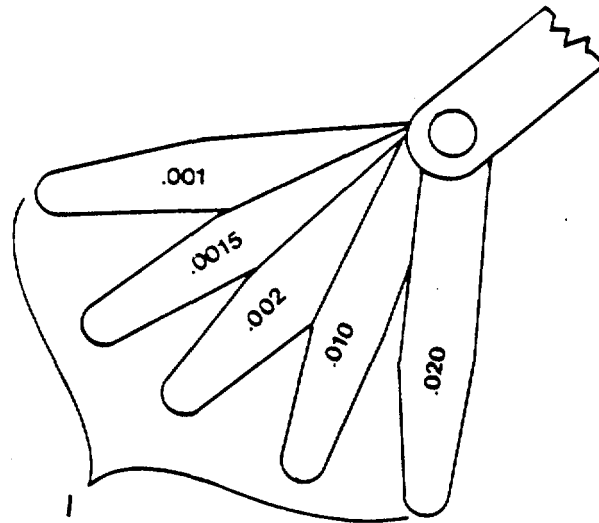

Figure 4-16. Thickness Gage

**Section II. MEASURING TECHNIQUES AND SCRIBING**

**4-3. General.**

Measuring tools are designed for measuring work accurately. They include calibrated measuring tools such as (rules, precision tapes, and micrometers) designed to measure distances in accordance with one of several standards of measurement.

**4-4. Types of Rules.**

Steel rules (fig. 4-17) are available from a fraction of an inch in length up to 4 feet or more, but in machine shops the steel machinist rule is the one most commonly used. There are also several standard systems of graduations. In the English system, rules are graduated in 10ths, 20ths, 50ths, and 100ths; 16ths, 32nds, and 64ths of an inch. In the Metric system, rules are graduated in millimeters and one-half millimeters. Some steel rules have four scales, two on each side (one graduated in 32nds and the other in 64ths) with the scales on the reverse side running in the opposite direction. There are rules made that have both an inch scale and millimeter scale, which makes this type rule adaptable to work involving both systems of measure. Another feature on some rules is a scale etched across the end of the rule which facilitates measurement in restricted places.

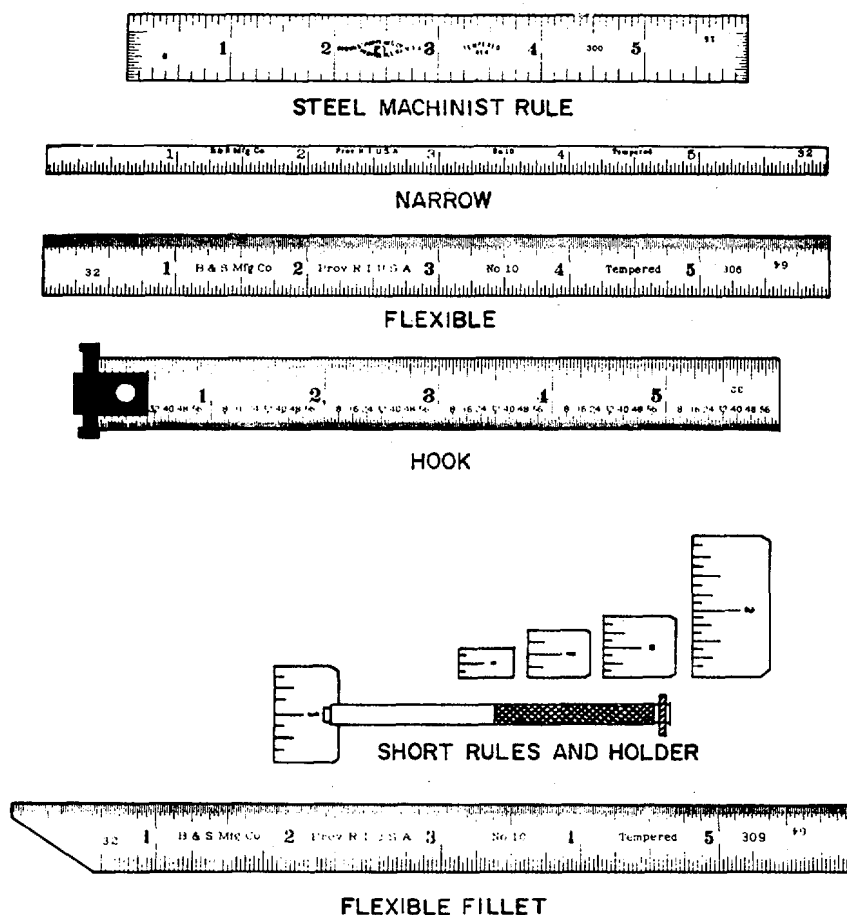

Figure 4-17. Types of Steel Rules

4-5. Using the Rule.

a. Scale Selection. The proper graduated scale should be used to control the reading of the dimension A (fig. 4-18). If the work being measured lines up between two graduations on the scale as shown in B (fig. 4-18) and it is not possible to read this dimension to a 1/16 on a 1/16 inch scale, a 1/32 inch scale should be used; and if it is still impossible to read a dimension to a 1/32, a 1/64 inch scale should be used.

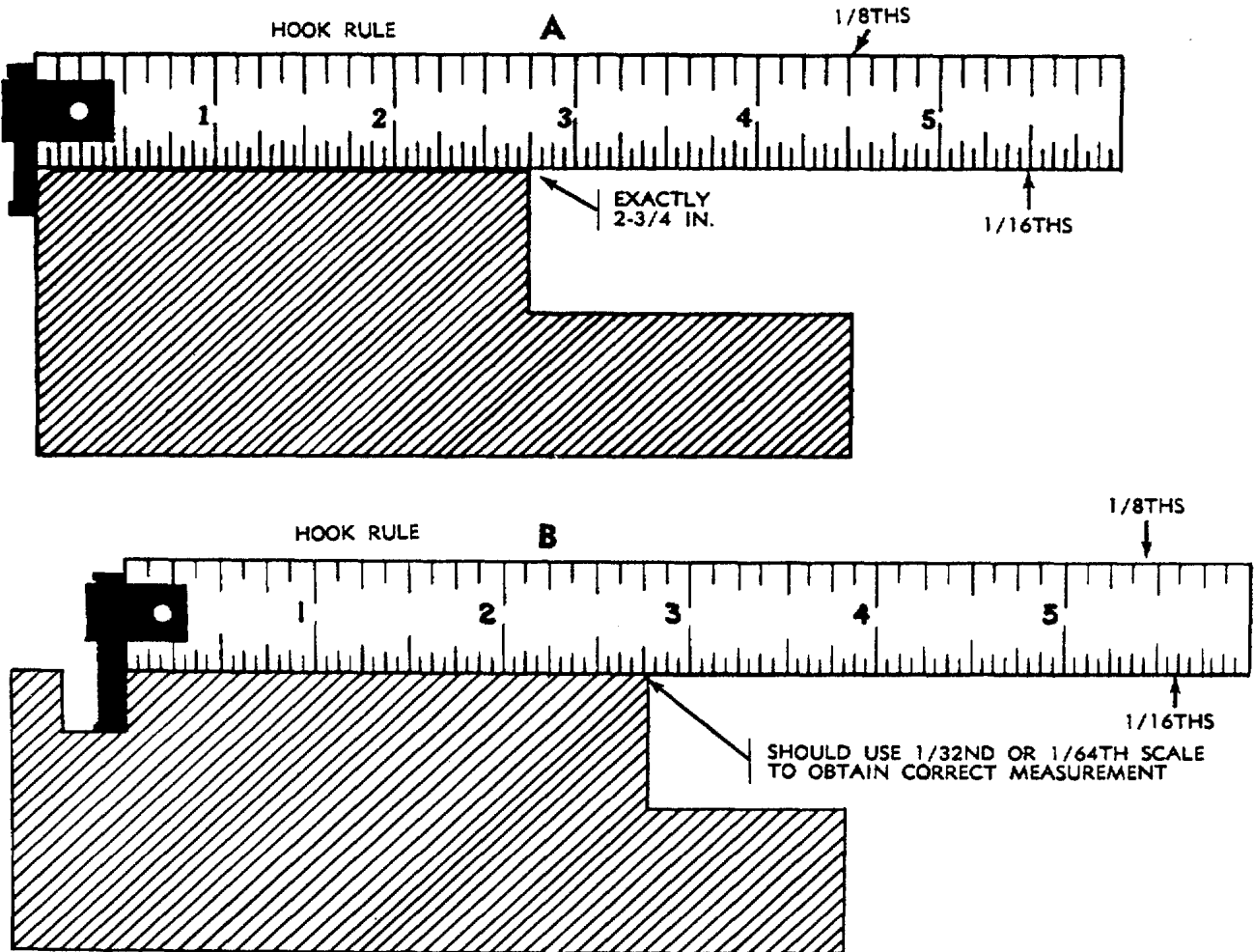

Figure 4-18. Determining Proper Graduated Rule



4-5. Using the Rule - Continued

b. Measuring Technique (fig. 4-19). Often it is necessary to measure a piece of work which has a length larger than the rule which is used to do the measuring. An example of this would be measuring an 18 inch length of stock with a steel machinist rule (fig. 4-19).

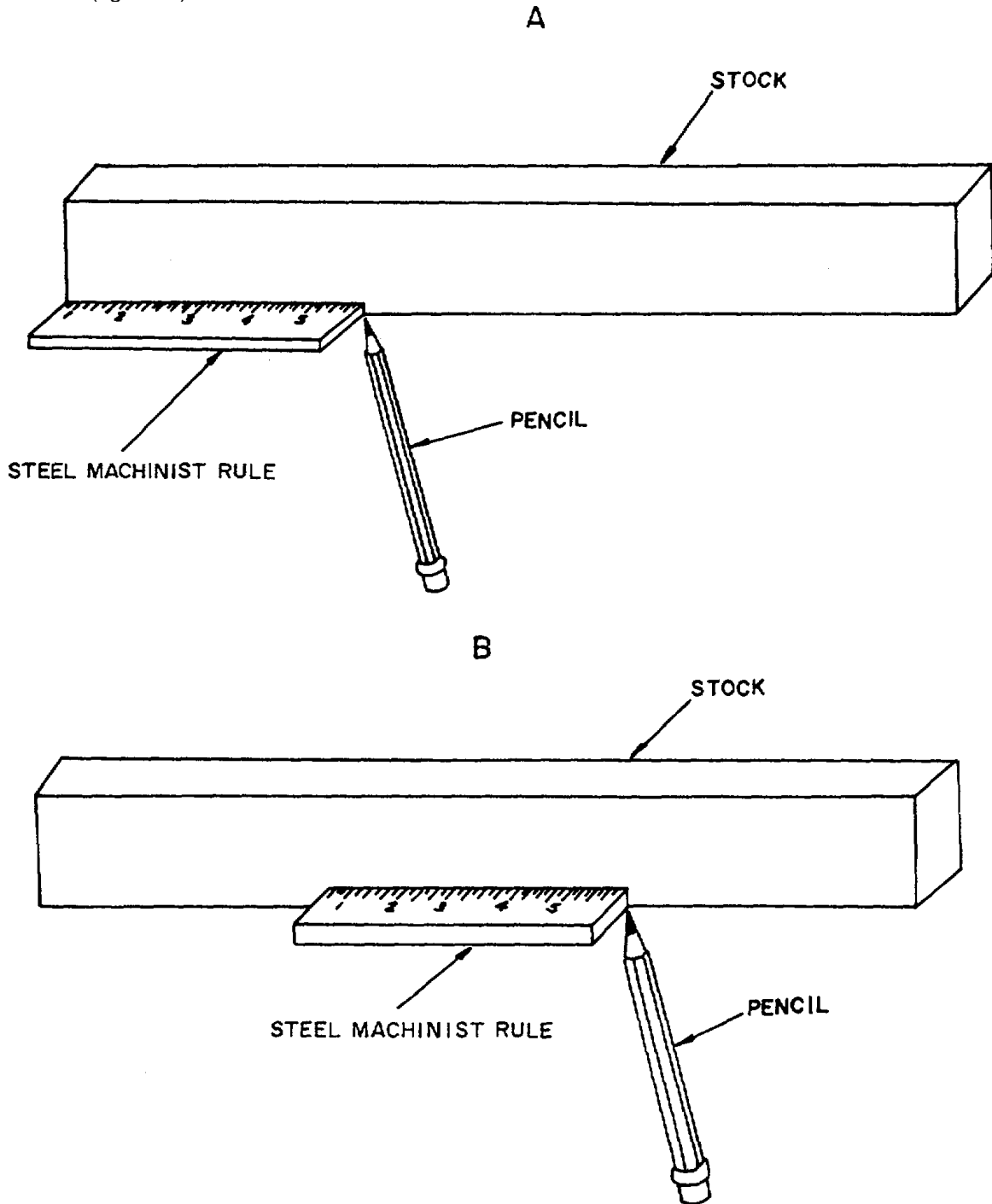

Figure 4-19. Measuring Technique

- (1) Aline the end of the steel machinist rule with the edge of the stock being measured A (fig. 4-19).
- (2) Use a pencil or scribe and mark the stock at the 6 inch measurement.

**4-5. Using the Rule - Continued**

- (3) Move the steel machinist rule along the stock being measured until the opposite end of the rule is alined with the mark made in (2) above B (fig. 4-19).
- (4) Insure that the edge of the rule is placed against the stock and make another mark, on the stock, at the 6 inch measurement.
- (5) Continue to move the steel machinist rule along the stock and mark each 6 inch measurement as described in steps (3) and (4) above until the entire length of the stock has been measured.
- (6) Count the number of marks on the stock and multiply by the length of the rule used to make the measurement.

**Example 1:**

In this example a steel machinist rule is used to measure 18 inches of stock. There are three marks on the stock.

$$3 \text{ marks} \times 6 \text{ inches (length of rule)} = 18 \text{ inches}$$

- (7) If the length of the stock to be measured is not an equal multiple of the rule used, make the measurement as described in steps (1) through (6) above and add to that the length of any remaining portion of stock that is shorter than the rule.

**Example 2:**

In this example a 6-inch pocket rule is used to measure 23 inches of stock. There are three marks on the stock with 5 inches remaining.

$$3 \text{ marks} \times 6 \text{ inches (length of rule)} + 5 \text{ inches (portion of stock shorter than the rule)} = 23 \text{ inches.}$$

**4-6. Standards of Length.**

Two systems, the English and Metric, are commonly used in the design of measuring tools for linear measurements. The English system uses inches, feet, and yards, while the Metric system uses millimeters, centimeters, and meters. In relation to each other 1 inch is equivalent to 25.3995 millimeters, or 1 millimeter is equivalent to 0.039370 inch. Refer to tables 4-2 through 4-7 to facilitate conversion between systems.

4-6. Standards of Length-Continued

Table 4-2. Conversion - Millimeters to Inches

Milli-meters	Inches	Milli-meters	Inches	Milli-meters	Inches	Milli-meters	Inches
1	0.039370	26	1.023622	51	2.007874	76	2.992126
2	0.078740	27	1.062992	52	2.047244	77	3.031496
3	0.118110	28	1.102362	53	2.086614	78	3.070866
4	0.157480	29	1.141732	54	2.125984	79	3.110236
5	0.196850	30	1.181102	55	2.165354	80	3.149606
6	0.236220	31	1.220472	56	2.204724	81	3.188976
7	0.275591	32	1.259843	57	2.244094	82	3.228346
8	0.314961	33	1.299213	58	2.283465	83	3.267717
9	0.354331	34	1.338583	59	2.322835	84	3.307087
10	0.393701	35	1.377953	60	2.362205	85	3.346457
11	0.433071	36	1.417323	61	2.401575	86	3.385827
12	0.472441	37	1.456693	62	2.440945	87	3.425197
13	0.511811	38	1.496063	63	2.480315	88	3.464567
14	0.551181	39	1.535433	64	2.519685	89	3.503937
15	0.590551	40	1.574803	65	2.559055	90	3.543307
16	0.629921	41	1.614173	66	2.598425	91	3.582677
17	0.669291	42	1.653543	67	2.637795	92	3.622047
18	0.708661	43	1.692913	68	2.677165	93	3.661417
19	0.748031	44	1.732283	69	2.716535	94	3.700787
20	0.787402	45	1.771654	70	2.755906	95	3.740157
21	0.826772	46	1.811024	71	2.795276	96	3.779528
22	0.866142	47	1.850394	72	2.834646	97	3.818898
23	0.905512	48	1.889764	73	2.874016	98	3.858268
24	0.944882	49	1.929134	74	2.913386	99	3.897638
25	0.984252	50	1.968504	75	2.952756	100	3.937008

4-6. Standards of Length - Continued

Table 4-3. Conversion - Fractions of an Inch to Decimals of an Inch, and Millimeters

Fraction of inch	Decimal of inch	Millimeters	Fraction of inch	Decimal of inch	Millimeters
1/64	0.015625	0.3968	33/64	0.515625	13.0966
1/32	0.03125	0.7937	17/32	0.53125	13.4934
3/64	0.046875	1.1906	35/64	0.546875	13.8903
1/16	0.0625	1.5875	9/16	0.5625	14.2872
5/64	0.078125	1.9843	37/64	0.578125	14.6841
3/32	0.09375	2.3812	19/32	0.59375	15.0809
7/64	0.109375	2.7780	39/64	0.609375	15.4778
1/8	0.125	3.1749	5/8	0.625	15.8747
9/64	0.140625	3.5718	41/64	0.640625	16.2715
5/32	0.15625	3.9686	21/32	0.65625	16.6684
11/64	0.171875	4.3655	43/64	0.671875	17.0653
3/16	0.1875	4.7624	11/16	0.6875	17.4621
13/64	0.203125	5.1592	45/64	0.703125	17.8590
7/32	0.21875	5.5561	23/32	0.71875	18.2559
15/64	0.234375	5.9530	47/64	0.734375	18.6527
1/4	0.25	6.3498	3/4	0.75	19.0496
17/64	0.265625	6.7467	49/64	0.765625	19.4465
9/32	0.28125	7.1436	25/32	0.78125	19.8433
19/64	0.296875	7.5404	51/64	0.796875	20.2402
5/16	0.3125	7.9373	13/16	0.8125	20.6371
21/64	0.328125	8.3342	53/64	0.828125	21.0339
11/32	0.34375	8.7310	27/32	0.843750	21.4308
23/64	0.359375	9.1279	55/64	0.859375	21.8277
3/8	0.375	9.5248	7/8	0.875	22.2245
25/64	0.390625	9.9216	57/64	0.890625	22.6214
13/32	0.40625	10.3185	29/32	0.90625	23.0183
27/64	0.421875	10.7154	59/64	0.921875	23.4151
7/16	0.4375	11.1122	15/16	0.9375	23.8120
29/64	0.453125	11.5091	61/64	0.953125	24.2089
15/32	0.46875	11.9060	31/32	0.96875	24.6057
31/64	0.484375	12.3029	63/64	0.984375	25.0026
1/2	0.5	12.6997	1	1.0	25.3995

4-6. Standards of Length - Continued

Table 4-4. Conversion - Decimals of an Inch to Millimeters

Decimals of inch	Millimeter	Decimals of inch	Millimeter	Decimal of inch	Millimeter
0.001	0.02540	0.035	0.88900	0.068	1.72720
0.002	0.05080	0.036	0.91440	0.069	1.75260
0.003	0.07620	0.037	0.93980	0.070	1.77800
0.004	0.10160	0.038	0.96520	0.071	1.80340
0.005	0.12700	0.039	0.99060	0.072	1.82880
0.006	0.15240	0.040	1.01600	0.073	1.85420
0.007	0.17780	0.041	1.04140	0.074	1.87960
0.008	0.20320	0.042	1.06680	0.075	1.90500
0.009	0.22860	0.043	1.09220	0.076	1.93040
0.010	0.25400	0.044	1.11760	0.077	1.95580
0.011	0.27940	0.045	1.14300	0.078	1.98120
0.012	0.30480	0.046	1.16840	0.079	2.00660
0.013	0.33020	0.047	1.19380	0.080	2.03200
0.014	0.35560	0.048	1.21920	0.081	2.05740
0.015	0.38100	0.049	1.24460	0.082	2.08280
0.016	0.40640	0.050	1.27000	0.083	2.10820
0.017	0.43180	0.051	1.29540	0.084	2.13360
0.018	0.45720	0.052	1.32080	0.085	2.15900
0.019	0.48260	0.053	1.34620	0.086	2.18440
0.020	0.50800	0.054	1.37160	0.087	2.20980
0.021	0.53340	0.055	1.39700	0.088	2.23520
0.022	0.55880	0.056	1.42240	0.089	2.26060
0.023	0.58420	0.057	1.44780	0.090	2.28600
0.024	0.60960	0.058	1.47320	0.091	2.31140
0.025	0.63500	0.059	1.49860	0.092	2.33680
0.026	0.66040	0.060	1.52400	0.093	2.36220
0.027	0.68580	0.061	1.54940	0.094	2.38760
0.028	0.71120	0.062	1.57480	0.095	2.41300
0.029	0.73660	0.063	1.60020	0.096	2.43840
0.030	0.76200	0.064	1.62560	0.097	2.46380
0.031	0.78740	0.065	1.65100	0.098	2.48920
0.032	0.81280	0.066	1.67640	0.099	2.51460
0.033	0.83820	0.067	1.70180	0.100	2.54000
0.034	0.86360				

4-6. Standards of Length - Continued

Table 4-5. Conversion - Inches to Millimeters

Inches	Milli-meters	Inches	Milli-meters	Inches	Milli-meters	Inches	Milli-meters
1	25.4	26	660.4	51	1295.4	76	1930.4
2	50.8	27	685.8	52	1320.8	77	1955.8
3	76.2	28	711.2	53	1346.2	78	1981.2
4	101.6	29	736.6	54	1371.6	79	2006.6
5	127.0	30	762.0	55	1397.0	80	2032.0
6	152.4	31	787.4	56	1422.4	81	2057.4
7	177.8	32	812.8	57	1447.8	82	2082.8
8	203.2	33	838.2	58	1473.2	83	2108.2
9	228.6	34	863.6	59	1498.6	84	2133.6
10	254.0	35	889.0	60	1524.0	85	2159.0
11	279.4	36	914.4	61	1549.4	86	2184.4
12	304.8	37	939.8	62	1574.8	87	2209.8
13	330.2	38	965.2	63	1600.2	88	2235.2
14	355.6	39	990.6	64	1625.6	89	2260.6
15	381.0	40	1016.0	65	1651.0	90	2286.0
16	406.4	41	1041.4	66	1676.4	91	2311.4
17	431.8	42	1066.8	67	1701.8	92	2336.8
18	457.2	43	1092.2	68	1727.2	93	2362.2
19	482.6	44	1117.6	69	1752.6	94	2387.6
20	508.0	45	1143.0	70	1778.0	95	2413.0
21	533.4	46	1168.4	71	1803.4	96	2438.4
22	558.8	47	1193.8	72	1828.8	97	2463.8
23	584.2	48	1219.2	73	1854.2	98	2489.2
24	609.6	49	1244.6	74	1879.6	99	2514.6
25	635.0	50	1270.0	75	1905.0	100	2540.0

4-6. Standards of Length - Continued

Table 4-6. Conversion - Feet to Meters

Feet	Meters	Feet	Meters	Feet	Meters
1	0.3048	35	10.6680	68	20.7264
2	0.6096	36	10.9728	69	21.0312
3	0.9144	37	11.2776	70	21.3360
4	1.2192	38	11.5824	71	21.6408
5	1.5240	39	11.8872	72	21.9456
6	1.8288	40	12.1920	73	22.2504
7	2.1336	41	12.4968	74	22.5552
8	2.4384	42	12.8016	75	22.8600
9	2.7432	43	13.1064	76	23.1648
10	3.0480	44	13.4112	77	23.4696
11	3.3528	45	13.7160	78	23.7744
12	3.6576	46	14.0208	79	24.0792
13	3.9624	47	14.3256	80	24.3840
14	4.2672	48	14.6304	81	24.6888
15	4.5720	49	14.9352	82	24.9936
16	4.8768	50	15.2400	83	25.2984
17	5.1816	51	15.5448	84	25.6032
18	5.4864	52	15.8496	85	25.9080
19	5.7912	53	16.1544	86	26.2128
20	6.0960	54	16.4592	87	26.5176
21	6.4008	55	16.7640	88	26.8224
22	6.7056	56	17.0688	89	27.1272
23	7.0104	57	17.3736	90	27.4320
24	7.3152	58	17.6784	91	27.7368
25	7.6200	59	17.9832	92	28.0416
26	7.9248	60	18.2880	93	28.3464
27	8.2296	61	18.5928	94	28.6512
28	8.5344	62	18.8976	95	28.9560
29	8.8392	63	19.2024	96	29.2608
30	9.1440	64	19.5072	97	29.5656
31	9.4488	65	19.8120	98	29.8704
32	9.7536	66	20.1168	99	30.1752
33	10.0584	67	20.4216	100	30.4800
34	10.3632				

4-6. Standards of Length - Continued

Table 4-7. Conversion - Meters to Feet

Meters	Feet	Meters	Feet	Meters	Feet
1	3.28983	35	113.81805	68	222.08534
2	6.56166	36	117.09888	69	225.36617
3	9.84249	37	120.37971	70	228.65700
4	13.12332	38	123.66054	71	231.93783
5	16.40415	39	126.94137	72	235.21866
6	19.68498	40	130.22220	73	238.49949
7	22.96181	41	133.50303	74	241.78032
8	26.24164	42	136.78386	75	245.06115
9	29.52147	43	140.06469	76	248.34198
10	32.80130	44	143.34552	77	251.62281
11	36.08113	45	146.62635	78	254.90364
12	39.36196	46	149.90718	79	258.18447
13	42.64179	47	153.18801	80	261.46530
14	45.92162	48	156.46884	81	265.74613
15	49.20145	49	159.74967	82	269.02696
16	52.48228	50	163.03050	83	272.30779
17	55.76311	51	166.31133	84	275.58862
18	59.04394	52	169.59216	85	278.86945
19	62.32477	53	172.87299	86	282.15028
20	65.60560	54	176.15382	87	285.43111
21	68.88643	55	179.43465	88	288.71194
22	72.16726	56	182.71548	89	291.99277
23	75.44809	57	185.99631	90	295.27360
24	78.72892	58	189.27714	91	298.55443
25	82.00975	59	192.55797	92	301.83526
26	85.29058	60	195.83870	93	305.11609
27	88.57141	61	199.11953	94	308.29692
28	91.85224	62	202.40036	95	311.67775
29	94.13307	63	205.68119	96	314.95858
30	97.41390	64	208.96202	97	318.23941
31	100.69473	65	212.24285	98	321.52024
32	103.97556	66	215.52368	99	324.80107
33	107.25639	67	218.80451	100	328.08190
34	100.53722				

4-7. Scribes.

Scribes are used to mark and lay out a pattern of work to be followed in subsequent machining operations. Scribes are made for scribing, scoring, or marking many different kinds of materials such as glass, steel, aluminum, copper, and so forth.



#### 4-8. Types of Scribes.

a. Machinist's Scribes (fig. 4-20). Machinist's single point pocket-type scribes have a scribe point made of tempered high grade steel and a handle of steel tubing that is nickel plated. The point is reversible, telescoping into the knurled handle when not in use. This type scribe usually has a 1/4 or 3/8 inch diameter handle with a point length of 2-3/8 or 2-7/8 inches. Bent point scribes are usually 8 to 12 inches long with one straight point, and one long or one short bent point. Some of these scribes are threaded and can be engaged in either end of the handle. The long bent point is designed for reaching through holes beyond a lip or ridge.

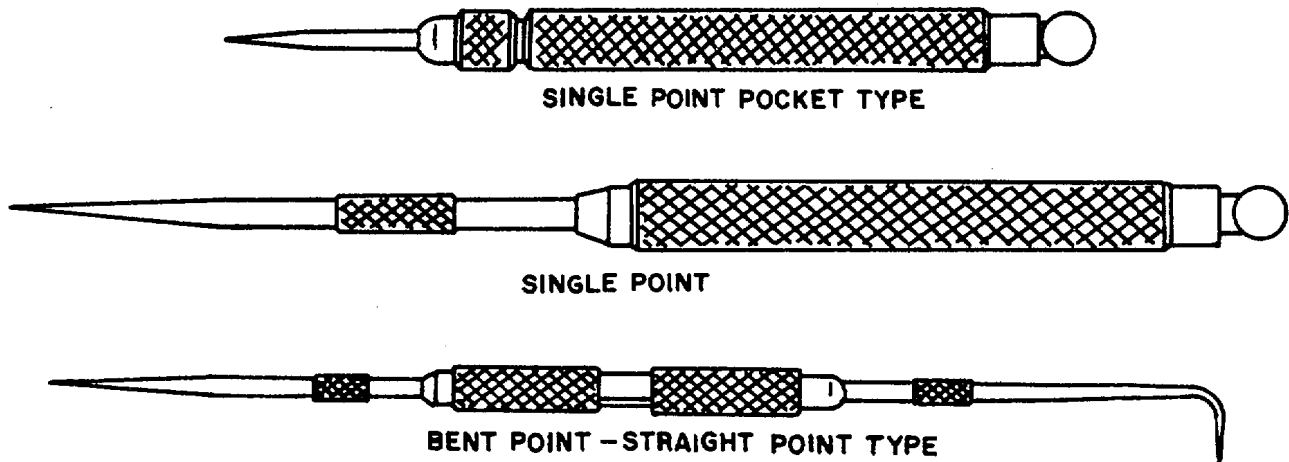

Figure 4-20. Types of Machinist's Scribes

b. Tungsten Carbide Scribes. These scribes are used to lay out lines on very hard materials, such as hardened steel and glass. The scribe point is made of tungsten carbide, a long wearing material, which makes it possible to scribe sharp, well defined lines on the hardest materials. Some of these scribes are used with an extension in conjunction with a vernier height gage, which allows reverse measurements, to be taken from the top of the bottom side of the gage jaw. This type scribe is hardened, ground, and lapped to a point so that a line or series of lines may be drawn and spaced as required in laying out of dies, and so forth.

#### 4-9. Using the Scriber.

- a. Sharpness. Make sure the point of the scriber is sharp. To sharpen, rotate the scriber between the thumb and forefinger while moving the point back-and forth on an oilstone.
- b. Work Surface. Clean work surfaces of all dirt and oil.
- c. Steel Rule. Place a steel rule or straight edge on the work beside the line to be scribed.
- d. Holding the Scriber. Use the fingertips of one hand to hold the rule in position and hold the scriber in the other hand as you would a pencil (fig. 4-21).

#### 4-8. Using the Scribes-Continued

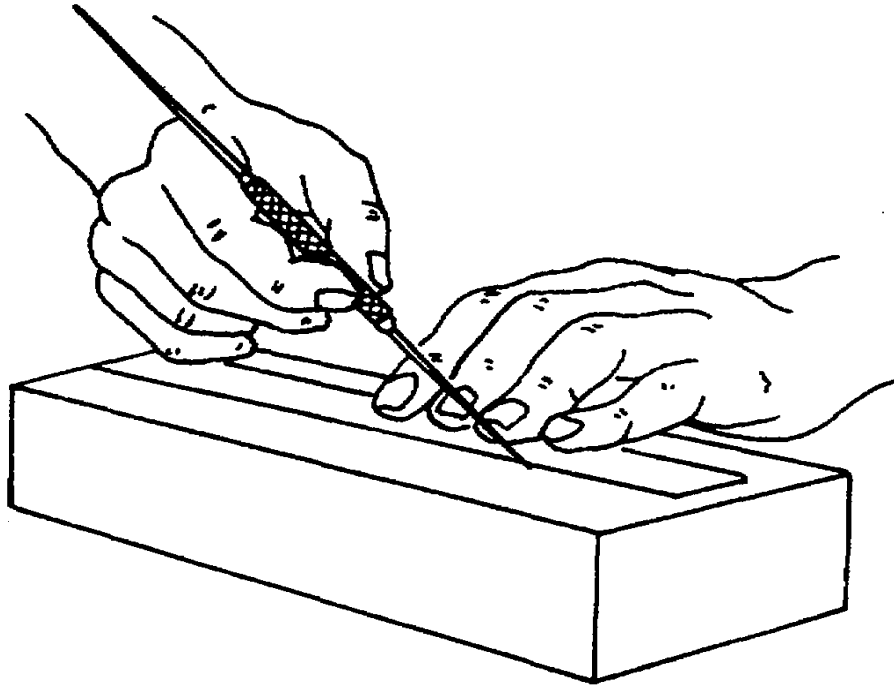

Figure 4-21. Using the Scriber

e. Scribing the Line. Scribe the line by drawing the scribe along the edge of the rule, at a 45 degree angle and tipped outward slightly in the direction it is being moved.

#### 4-10. Care of Scribes.

Place a cork or soft wood over the point of scribe when not in use. Coat scribe with rust prevention compound before storage. Do not store scribes in drawer with other tools. This practice can cause damage to scribes and injury to personnel. Rack properly and stow in a suitable box. Do not use scribes for purposes other than those intended.

### Section III. SOLDERING AND DESOLDERING TECHNIQUES

#### 4-11. Soldering.

Soldering is joining two pieces of metal by adhesion. The soldering iron is the source of heat for melting solder and heating the parts to be joined to the proper temperature.

#### 4-12. Soldering Station.

a. General. Temperature regulation is an important factor when making any solder connection. For this reason, never use an electric soldering gun. Use an electric soldering station such as the one shown in figure 4-22.

## 4-12. Soldering Station-continued

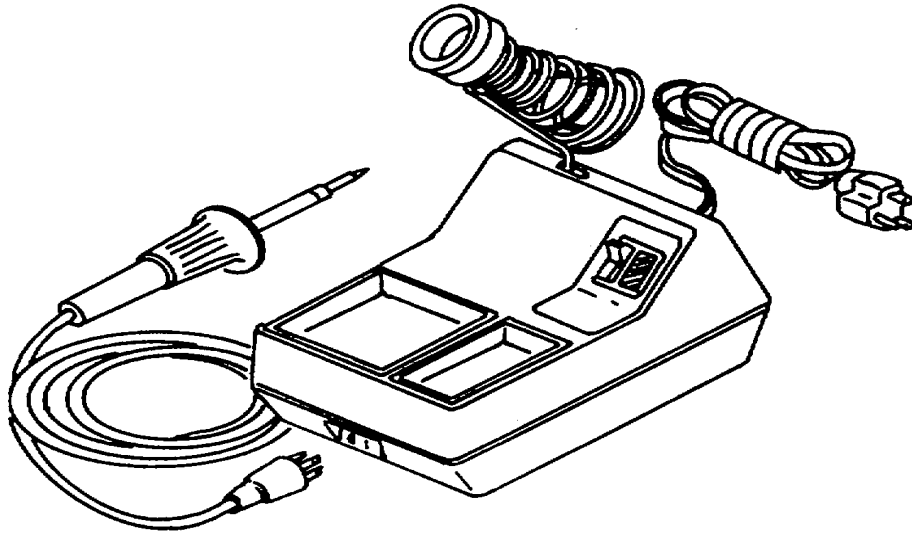

Figure 4-22. Electric Soldering Station

b. Principles of Operation. The electric soldering iron transmits heat to the tip after the heat is produced by electric current which flows through a self-contained coil of resistance wire called the heating element (fig. 4-23).

- (1) This type of soldering iron contains a closed loop method of automatically controlling maximum tip temperature thereby protecting temperature sensitive components.
- (2) The tip (3) is electrically grounded to protect voltage and current sensitive components. Tip sizes range from one thirty-second of an inch in diameter to fifteen sixty-fourth of an inch in diameter with a choice of tip temperatures 600, 700, and 800°F.
- (3) The power unit base (7) contains a tray (8) for holding iron tips, a sponge (9) for keeping the tip clean, and an iron holder (10) for supporting the iron when not in use.

c. Tinning the Soldering Tip (fig. 4-23). Before any soldering can be accomplished, the tip should be tinned (coated with solder) to aid in heat transfer and assure good solder flow.

- (1) Select the desired size tip (3) and position tip into barrel nut assembly (4). Secure barrel nut assembly to the heater (2) and place soldering iron (1) into iron holder (10).

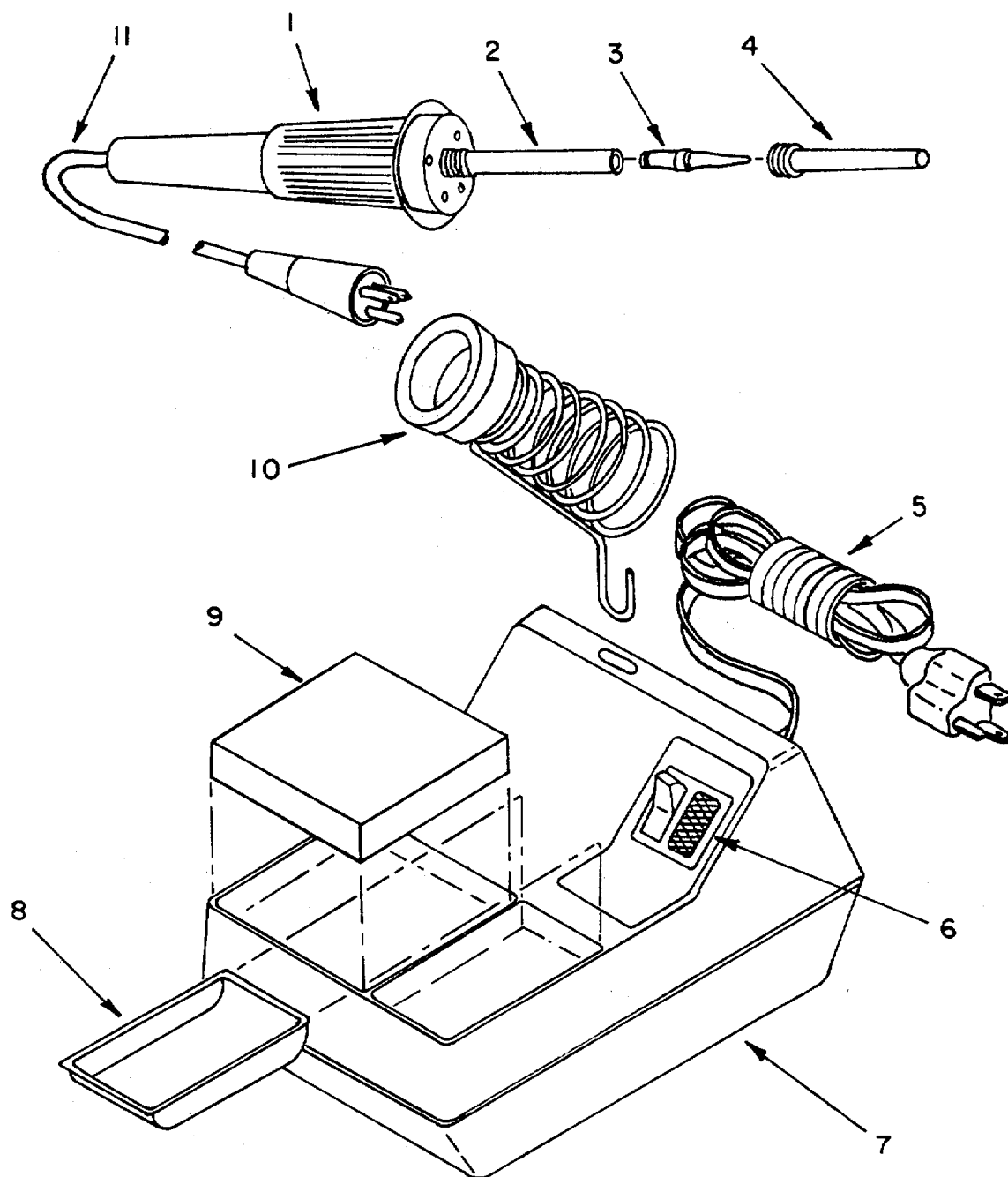

KEY to figure 4-23:

- |                        |                    |
|------------------------|--------------------|
| 1. Soldering iron      | 7. Power unit base |
| 2. Heater              | 8. Tip tray        |
| 3. Soldering tip       | 9. Sponge          |
| 4. Barrel nut assembly | 10. Iron holder    |
| 5. Power cord          | 11. Cord set       |
| 6. Power switch        |                    |

Figure 4-23. Electric Soldering Station - Exploded View

**4-12. Soldering Station - Continued**

- (2) Plug the cord (11) into the power unit base (7). Plug power cord (5) into electrical outlet.
- (3) Turn on power switch (6) and allow soldering tip (3) to heat.
- (4) Apply water to sponge (9) and remove soldering iron (1) from iron holder (10) and wipe tip (3) across sponge to clean off any foreign material.

**NOTE**

**When soldering electrical parts and wiring, always use a rosin core solder or solid solder with a rosin flux.**

- (5) Rub rosin core solder over the face of the tip (3). As soon as the temperature rises sufficiently, the solder will melt and spread smoothly over the face of the tip. The purpose of this procedure is to tin the tip as soon as it becomes hot enough to melt solder and before it has had a chance to oxidize.
- (6) When the tinning is complete, wipe the tip (3) across the sponge (9) while the solder is hot and molten. This will expose an even, almost mirror like layer of molten solder on the tip face.

**4-13. Soldering Techniques.**

a. Using a Soldering Iron. Soldering can be broken down into seven major steps which include: precleaning, applying flux, applying heat, applying solder, cooling, flux removal, and inspection.

- (1) Precleaning. The work which is to be soldered must be perfectly clean. All oxide must be scraped off with a steel scratch brush, emery paper, steel wool, file or a knife, whichever works best for the particular job. Grease, dust, and oil must be removed from surfaces to be soldered with noncorrosive solvents such as trichloroethane, or alcohol.
- (2) Applying flux. Flux must wet the entire surface to which the solder is to adhere. When used, liquid flux must be applied in a thin even coat to the surfaces being joined prior to the application of heat. When using cored solder wire, place solder in a position that will allow the flux to flow over the joint as the solder melts.

**NOTE**

- o **Some electronic components are heat sensitive and could be destroyed by heat. For this reason, a heat sink device such as surgical tweezers, needle nose pliers, or heat sinks should always be applied between the solder joint and the electronic component.**
- o **If a soldering iron becomes too cool to solder, it is too small for the job and an iron with a higher wattage rating or a higher tip temperature should be used.**

## 4-13. Soldering Techniques-Continued

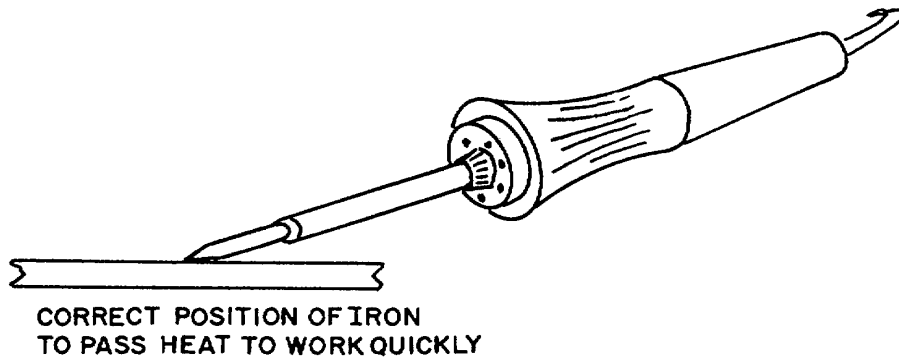
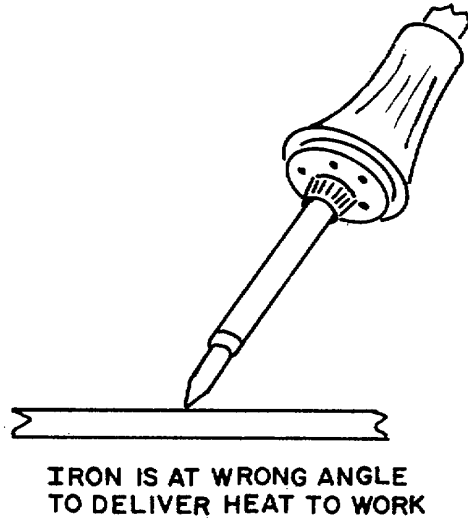

*Figure 4-24. Position of Tip for Maximum Heat Transfer*

- (3) Applying heat. Prior to applying heat, the work must first be properly and rigidly supported. If a joint is moved while the solder is cooling and setting, the solder will be broken or weakened. Position the soldering iron against the work so that the tip will transfer the greatest amount of heat to the work being joined (fig. 4-24).
- (4) Applying solder. The areas to be joined must be heated to the correct temperature to cause the solder to melt. The solder is then applied to the joint and not to the soldering iron; however prior to touching the tip to the joint a very small quantity of solder may be applied to the tip of the iron to improve heat transfer. Apply enough solder to the connector to provide smooth well formed fillets between the surfaces being soldered (fig. 4-25).

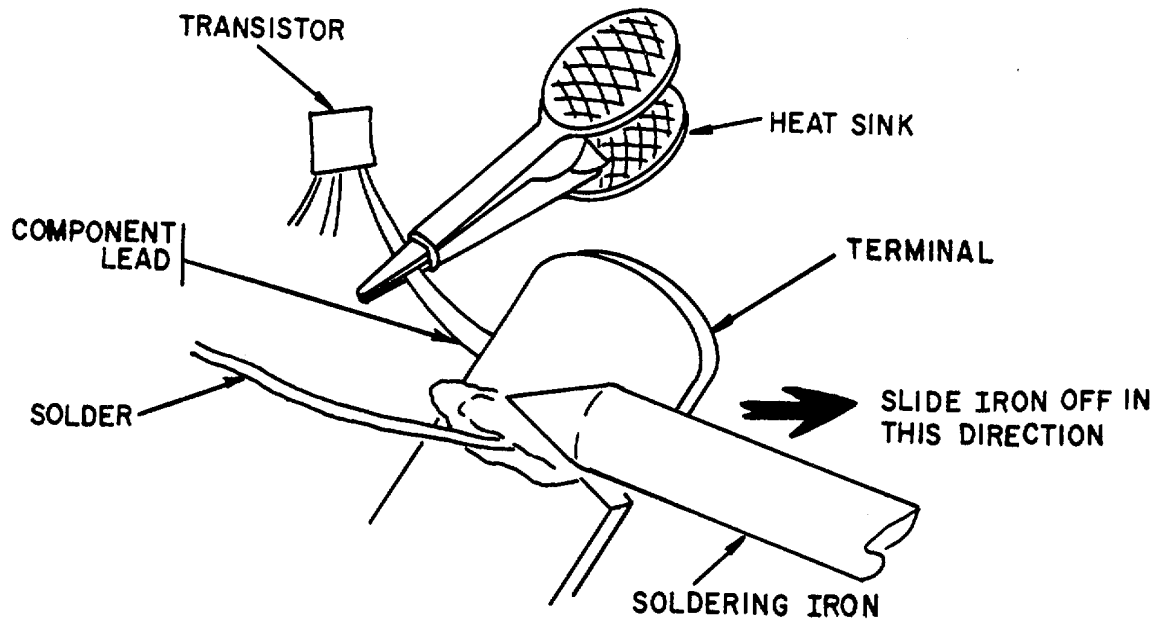

Figure 4-25. Applying Solder

- (5) Cooling. After the solder has been applied to the joint, the connection should not be moved or have stress applied to it during cooling. Never use any kind of liquid to cool a soldered connection, it should always be air cooled.
- (6) Flux residue removal. Flux residue should be removed within one hour after soldering. The best method for removal of flux residue is to dip a medium stiff bristle brush in alcohol and rub solder joint until all residue is removed.
- (7) Inspection. Inspect solder joint for defects such as not enough solder, too much solder, and cold solder joint. If resoldering is required, the same procedure should be followed as described in steps (1) through (6) above. A cold solder joint or disturbed joint will require only reheating and reflowing of the solder. The final step of any soldering operation should always be flux residue removal as described in step (6) above.

**4-13. Soldering Techniques - Continued**

b. Soldering With A Torch. In some situations soldering can not be accomplished using a soldering iron. Either the size of the work or the angle of the solder joint will not permit the use of a soldering iron, therefore a torch must be used. An example of this method, the soldering of the bellows assembly for the M118 series Elbow Telescope is described below.

- (1) Before soldering, preclean all areas of the bellows assembly, to be soldered, as described in paragraph a above.
- (2) Secure shouldered shaft (1, fig. 4-26) in a vice or other suitable holding device in such a manner that will allow easy access to all sides of the shaft during the soldering operations.

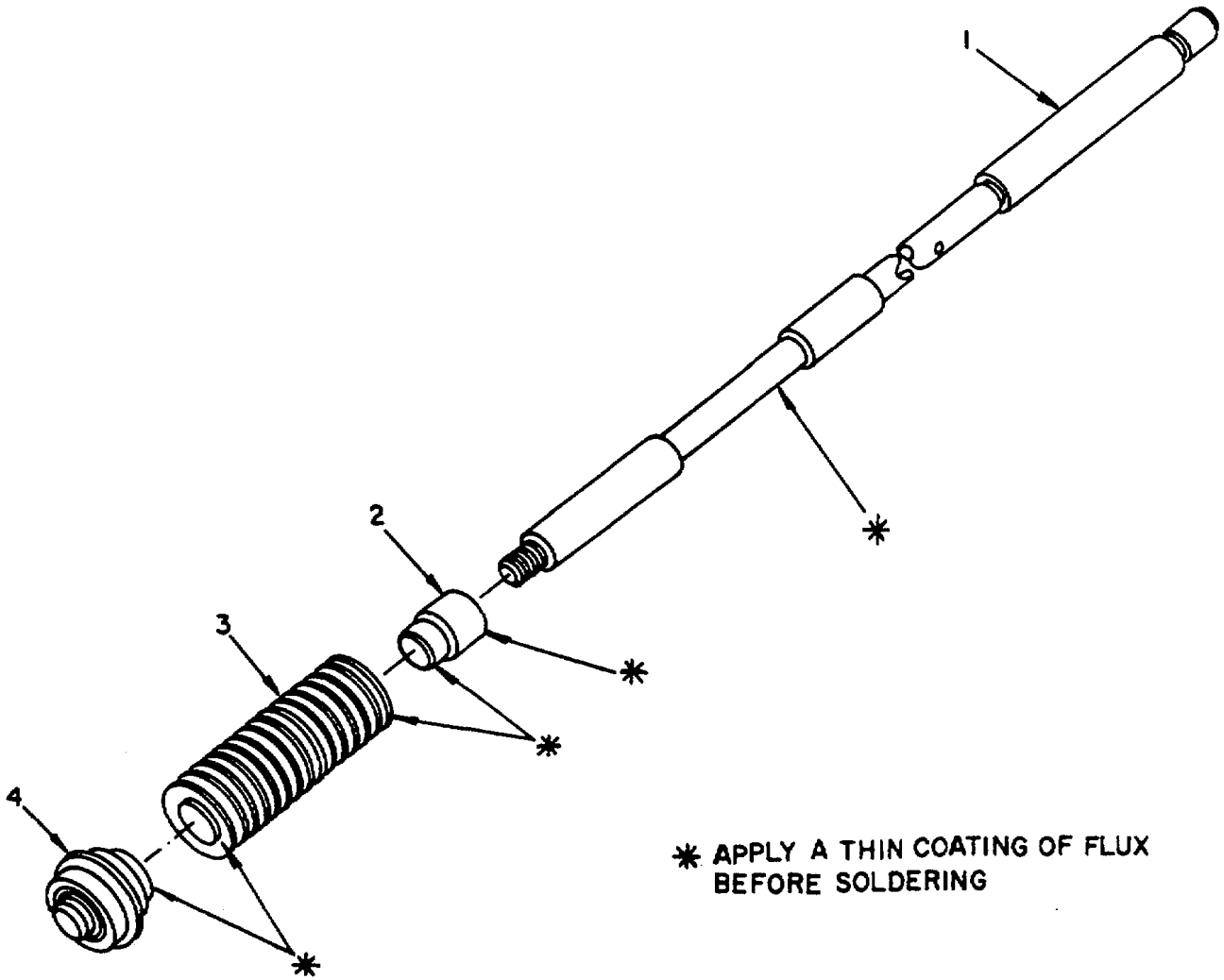

KEY to figure 4-26:

- |                               |                            |
|-------------------------------|----------------------------|
| 1. Shaft, shouldered 10512971 | 3. Bellows 8615885         |
| 2. Collar, shaft 8615969      | 4. Bushing, sleeve 8615968 |

Figure 4-26. Bellows Assembly 10512969 - Exploded View



## 4-13. Soldering Techniques - Continued

**WARNING**

Exercise good safety rules when operating a torch. The flame of a torch produces extremely high temperatures which can cause severe burn injuries.

**NOTE**

In steps (3) and (4) below, refer to figure 4-27.

- (3) Position the shaft collar (3) onto the shouldered shaft (1). Ignite the torch (4) and preheat the shouldered shaft and shaft collar. Periodically remove the flame of the torch from the area being heated and apply solder (2) to the joint of the shouldered shaft and the shaft collar. If solder does not melt into the joint, remove the solder and reapply heat.

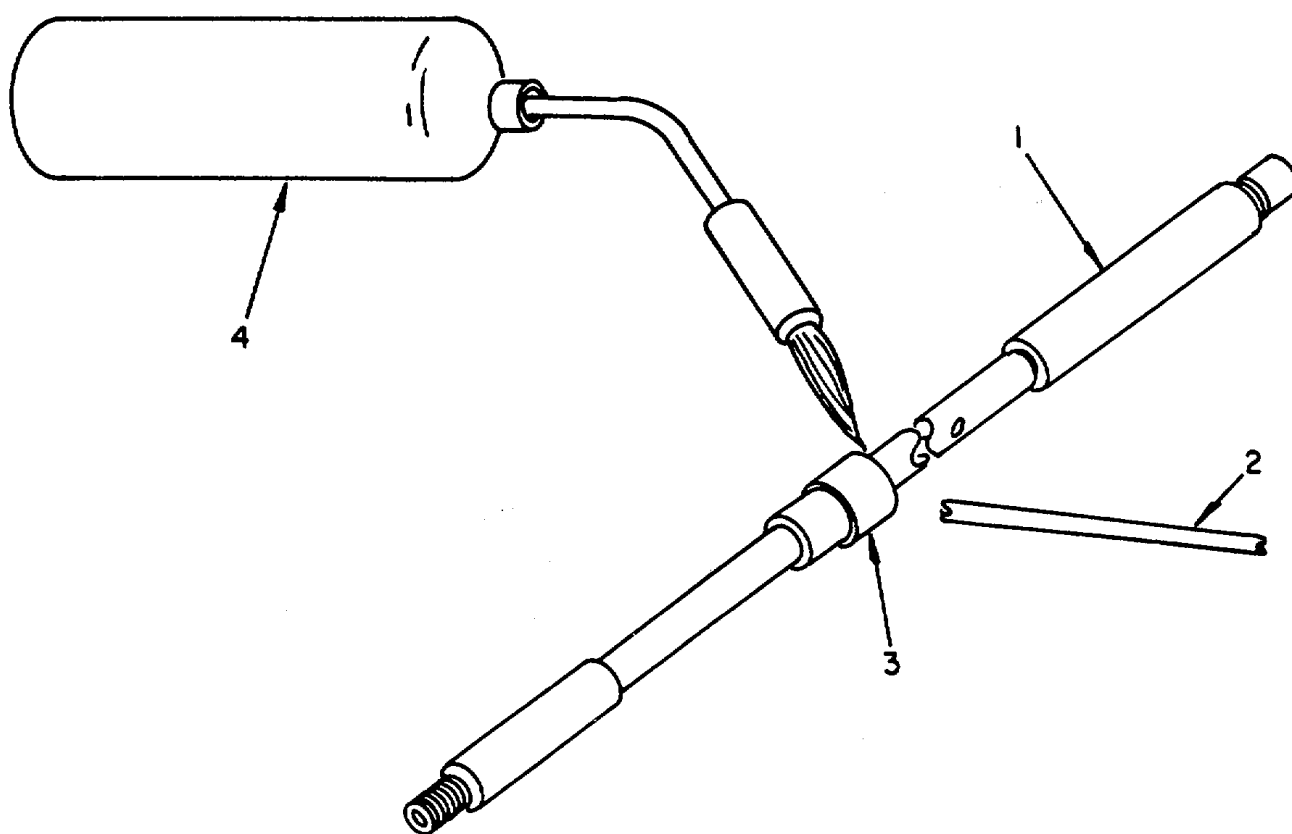

KEY to figure 4-27:

- |                      |                  |
|----------------------|------------------|
| 1. Shaft, shouldered | 3. Collar, shaft |
| 2. Solder            | 4. Torch         |

Figure 4-27. Soldering Shaft Collar to Shaft

4-13. Soldering Techniques - Continued

- (4) When the temperature of the shaft collar (3) and shouldered shaft (1) rises to a point that will cause the solder to melt and flow into the joint, discontinue heating with the torch and apply solder (2) to form an even-continuous fillet around the shaft collar and the shouldered shaft.

**NOTE**

In steps (5) and (6), refer to figure 4-28.

- (5) Position the bellows (3) onto the shouldered shaft (1) and up against the shaft collar (5). Preheat the bellows and shaft collar with the torch. Periodically remove the flame of the torch from the area being heated and apply solder (2) to the joint of the bellows and shaft collar. If the solder does not melt into the joint, remove solder and reapply heat from the torch.

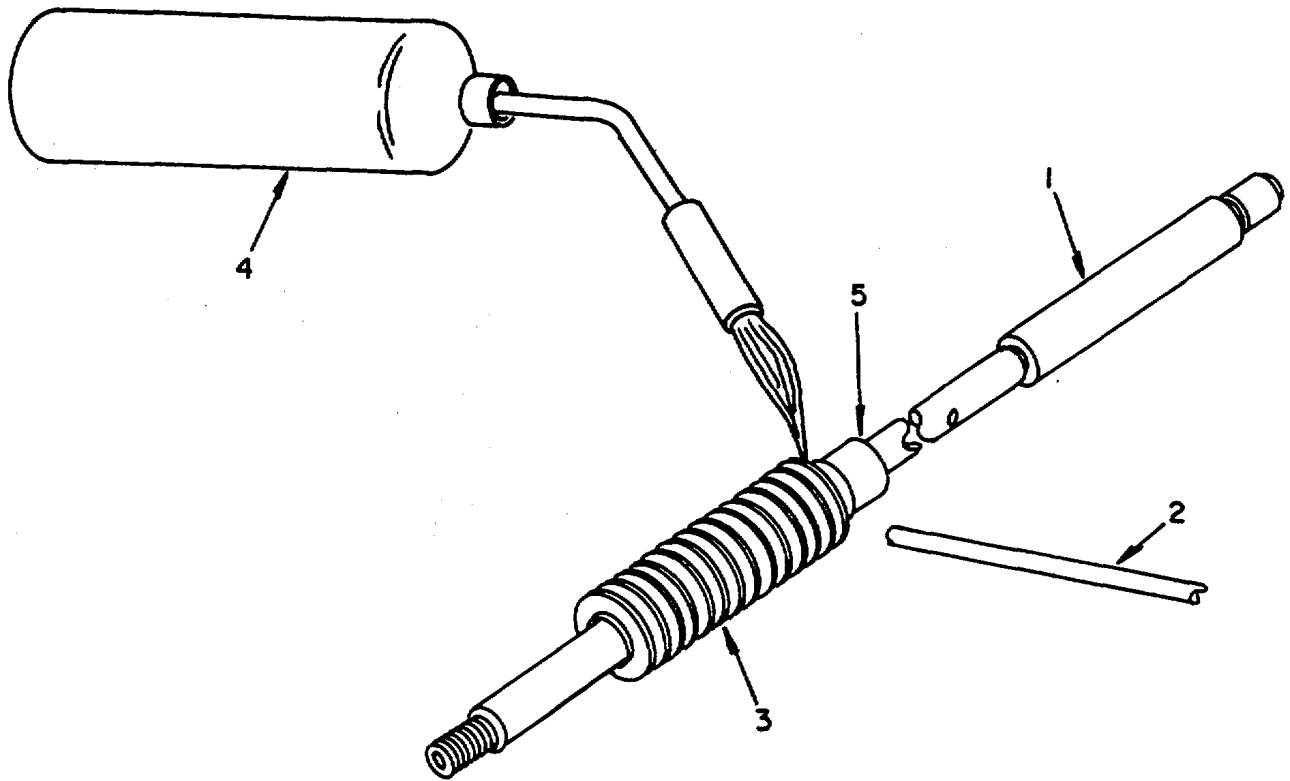

KEY to figure 4-28:

- |                      |                  |
|----------------------|------------------|
| 1. Shaft, shouldered | 4. Torch         |
| 2. Solder            | 5. Collar, shaft |
| 3. Bellows           |                  |

Figure 4-28. Soldering Bellows to Shaft Collar

## 4-13. Soldering Techniques - Continued

- 6) When the temperature of the bellows (3) and the shaft collar (5) rises to a point that will cause the solder to melt and flow into the joint, discontinue heating with the torch and apply solder (2) to form an even-continuous fillet around the bellows and shaft collar.

## NOTE

In steps (7) through (12), refer to figure 4-29.

- (7) Position the sleeve bushing (3) onto the shouldered shaft (1) and up against the bellows (5). Preheat the sleeve bushing and bellows with the torch. Periodically remove the flame of the torch from the area being heated and apply solder (2) to the joint of the sleeve bushing and the bellows. If the solder does not melt into the joint, remove solder and reapply heat from the torch.

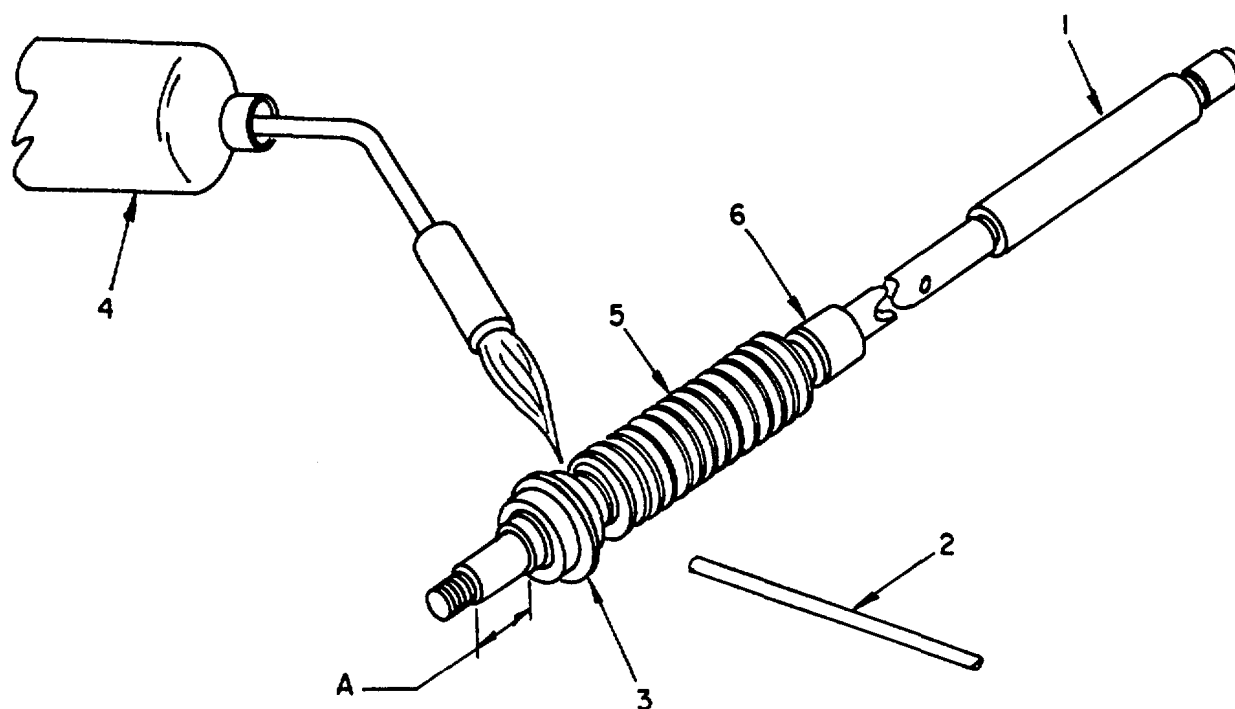

KEY to figure 4-29:

- |                      |                  |
|----------------------|------------------|
| 1. Shaft, shouldered | 4. Torch         |
| 2. Solder            | 5. Bellows       |
| 3. Bushing, sleeve   | 6. Collar, shaft |

Figure 4-29. Soldering Sleeve Bushing to Bellows

**4-13. Soldering Techniques - Continued**

- (8) When the temperature of the sleeve bushing (3) and the bellows (5) rises to a point that will cause the solder to melt and flow into the joint, discontinue heating with the torch and apply solder (2) to form an even-continuous fillet around the sleeve bushing and the bellows.

**NOTE**

**Heat applied to the bellows during the soldering operation will cause the bellows to change physical length.**

- (9) After the solder joints have cooled, measure the distance from the shouldered shaft (1) at the threaded end, to the sleeve bushing (3). The distance measured (A) must be between 0.468 and 0.500 inches.

**CAUTION**

**Do not score the sleeve bushing when using pliers to make adjustments to the bellows.**

- (10) If the measurement taken in step (10) is not within tolerance, reheat the bellows (5), do not apply heat to the solder joints. Grip the sleeve bushing (3) with a pair of pliers and either compress or stretch out the bellows.
- (11) Measure the distance (A) again and if necessary repeat step (10) above.
- (12) Allow the bellows assembly to cool completely and then remove all flux residue from the solder joints with a medium stiff bristle brush dipped in alcohol.

**4-14. Desoldering Techniques.**

Solder may be removed from conductors and terminals by mechanical vacuum devices, wicking with a stranded conductor, or shielding braid and flux. The stranded conductor or shielding braid method will be discussed in this section.

- (1) A well-tinned soldering iron tip shall be used to melt solder connections when conductor wires are removed from component terminals.
- (2) To remove conductors from solder joints, preclean joint to be desoldered with a noncorrosive solvent such as alcohol.
- (3) Choose a size of stranded wire or shielding braid that is large enough to do the job properly but not too large. The larger the stranded wire or shielding braid, the more heat required to desolder the joint and a greater possibility of damaging the circuit.
- (4) Dip approximately 1/2 inch of the stranded wire or shielding braid into liquid flux or use a commercially available desoldering wick that already contains the flux (app B). Shake off any excess.

#### 4-14. Desoldering Techniques - Continued

- (5) Position the stranded wire or shielding braid on the connection and place the hot soldering iron tip on top of the stranded wire or shielding braid as shown in figure 4-30.
- (6) Hold shielding braid and iron tip against joint or connection until the desired amount of solder is absorbed into shielding braid. Be careful not to over heat components. Remove the soldering iron tip and the shielding braid simultaneously.
- (7) Allow connection to cool and then remove the flux residue with alcohol and a medium stiff bristle brush.

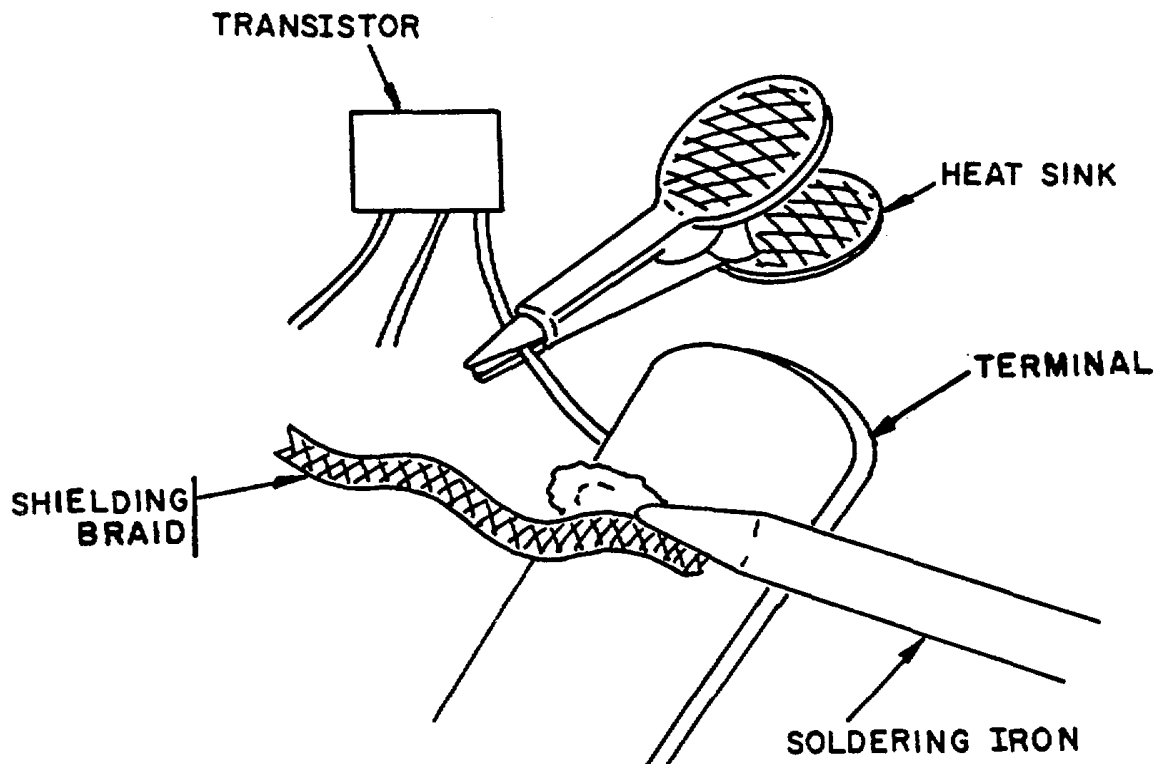

Figure 4-30. Wicking Procedure

#### 4-15. Stripping Insulated Wire.

a. General. Wire must be stripped of insulation before it can be tinned or soldered. There are two methods of removing insulation: thermal strippers for removing plastic insulation and mechanical strippers (precision cutting) for non-plastic insulation.

#### WARNING

**Good ventilation is required when using thermal strippers. Wire insulation gives off a toxic gas when melted.**

b. Thermal Stripper (fig. 4-31). A thermal stripper uses a small loop of resistance wire, heated by electric current to a high temperature.

#### 4-15. Stripping Insulated Wire - Continued

Insert the insulated wire into the thermal stripper and melt a ring around the insulation at the desired length to be stripped. Pull off the insulation between the melted ring and the end of the wire either with the thermal stripper or a pair of long-nose pliers.

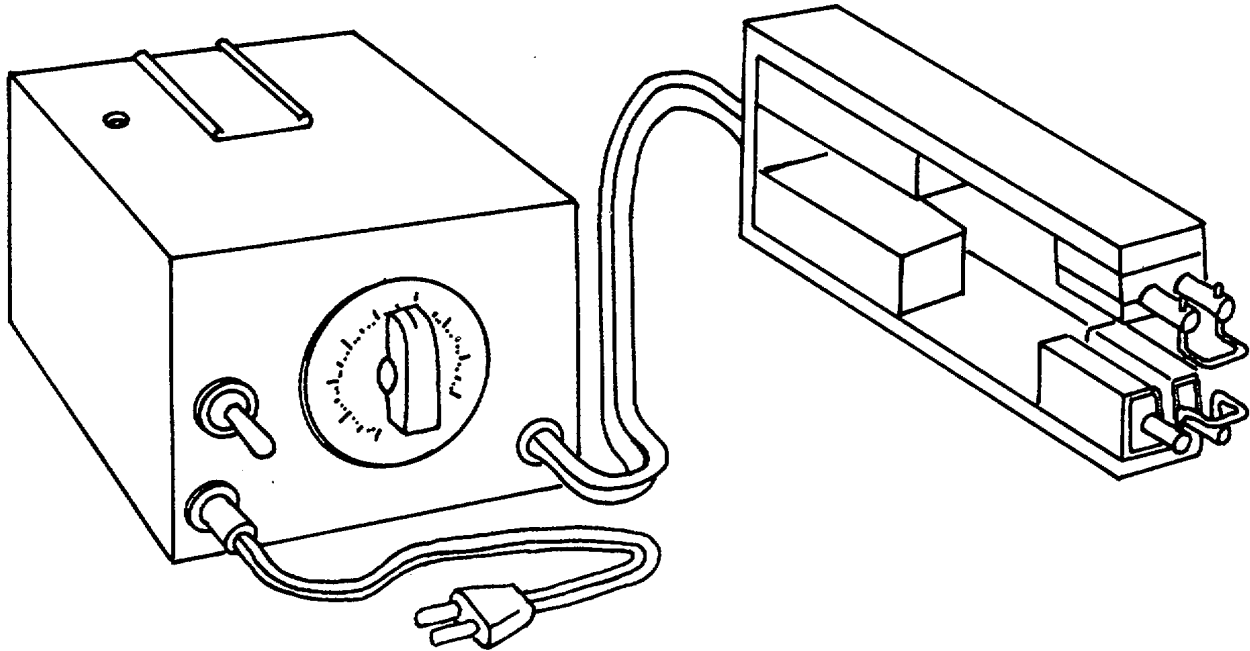

Figure 4-31. Thermal Stripper

#### CAUTION

The use of mechanical wire strippers may nick wire or break wire strands if not used properly. Nicked wire or broken strands of wire cause the wire to be mechanically weakened as well as reducing its current-carrying capacity.

#### NOTE

The use of adjustable wire strippers is not permitted. Adjustable wire strippers can become maladjusted causing broken strands or nicks in the wire.

c. Mechanical Stripper (fig. 4-32). A mechanical stripper uses a split cutting blade with notches. When closed, the split cutting blade becomes cutting holes completely encircling the wire to be stripped.

#### 4-15. Stripping Insulated Wire - Continued

Select the correct hole size to cut the insulation being careful not to nick, break or flair any wire strands. Test the selected hole size on a piece of wire of the same type and size as the actual wire being used.

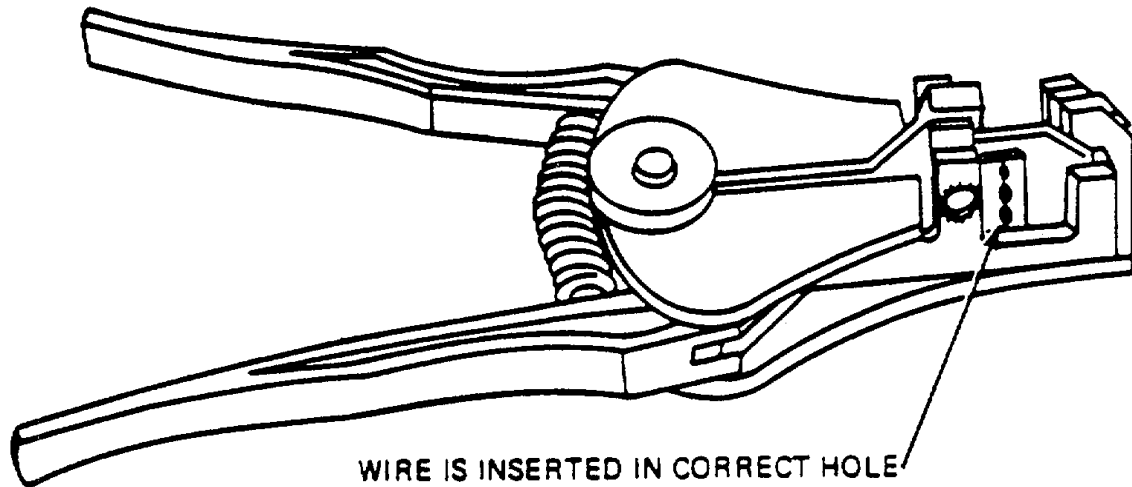

Figure 4-32. Mechanical Wire Strippers

#### 4-16. Tinning Wire.

Before a wire can be soldered to a connection it must first be tinned (pre-soldered). Tinning a wire will help the wire retain its original configuration and improve its mechanical strength. To properly tin a wire:

- (1) Inspect the wire center conductor or strands for any nicks or broken strands. If any are found, cut off the center conductor and re-strip the insulation as described in paragraph 4-15.
- (2) Twist stranded wire in the original direction of the individual strands to restore the rounded contour to the wire.

#### NOTE

**Heat shunts are available in standard sizes. Always use the appropriate size heat shunt according to the size of the wire being tinned.**

- (3) Clean the exposed center conductor (fig. 4-33) with alcohol and allow to dry. Apply a thin coat of flux to the center conductor before tinning.

4-16. Tinning Wire - Continued

- (4) Secure the wire to be tinned with a heat shunt (fig. 4-33). The use of a heat shunt will prevent solder from flowing beneath the insulation during tinning and soldering operations. Solder flow under the insulation is called wicking and is not permitted.

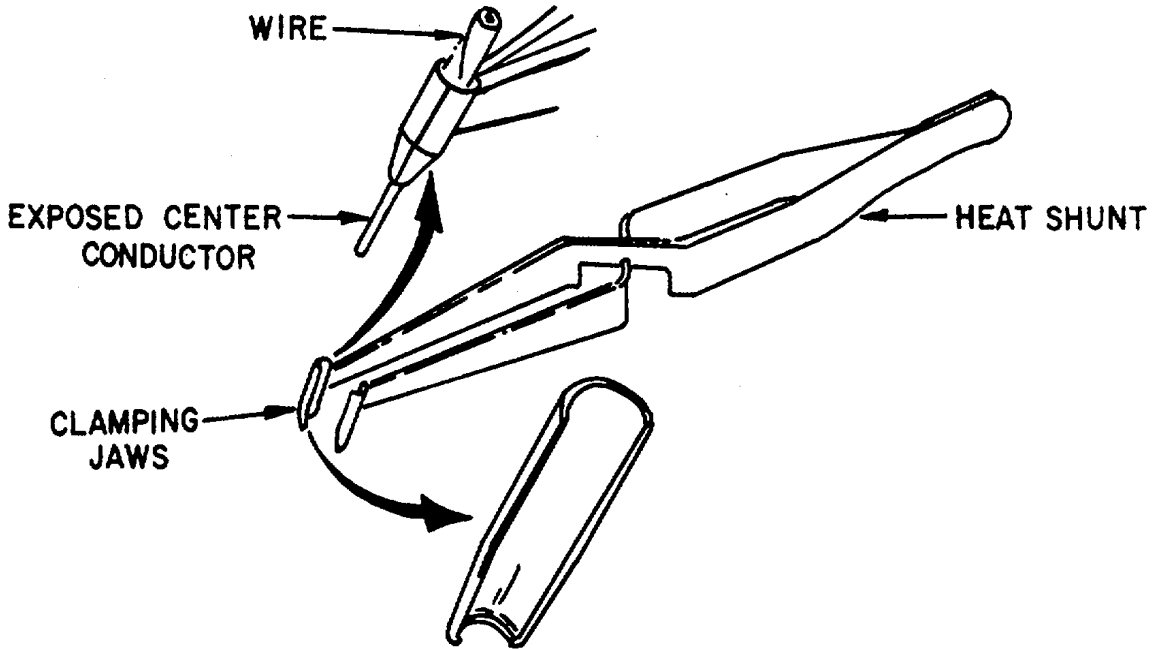

Figure 4-33. Using a Heat Shunt

- (5) Tin the wire (fig. 4-34) with a soldering iron by placing the exposed center conductor on the soldering iron tip until the center conductor becomes hot enough to melt solder. Apply solder all along the top of the center conductor until solder flows freely and evenly over and around the length to be tinned.

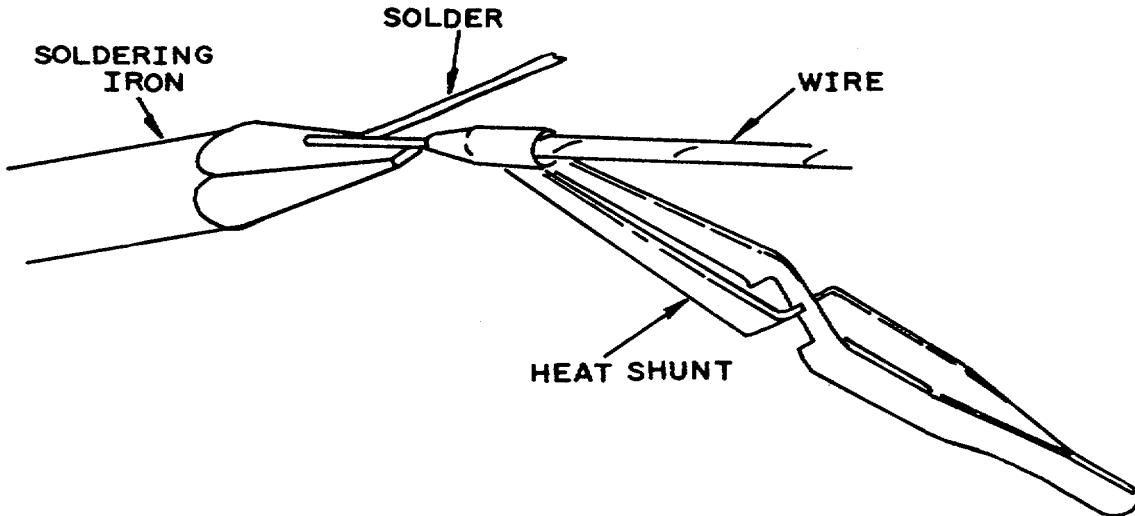

Figure 4-34. Wire Tinning



#### 4-16. Tinning Wire - Continued

- (6) Remove the wire from the soldering iron and allow it to cool before removing heat shunt from the wire. Clean tinned wire with alcohol and a medium stiff bristle brush to remove all flux residue.
- (7) Clean the inside of the clamping jaws of the heat shunt (fig. 4-33) with alcohol and a medium stiff bristle brush to remove all flux residue.
- (8) Inspect tinned wire for a smooth even layer of solder (fig. 4-35). The solder coverage on the wire must be thin enough to show wire strands. Solder coating must not extend under insulation. Wicking (sucking of solder up along the strands during the tinning process) often makes the solder flow farther than intended and results in solder under the insulation. Wicking must be avoided.

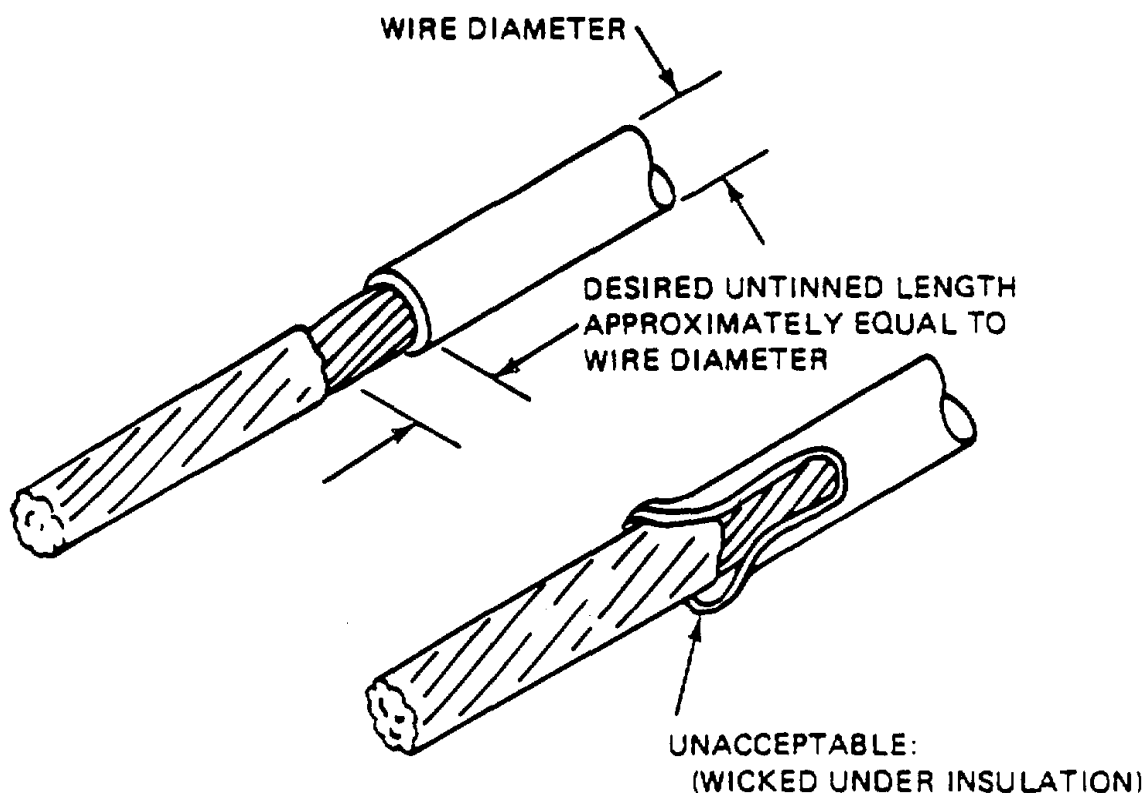

Figure 4-35. Tinned Wires - Examples

#### 4-17. Printed Circuit Boards.

a. Printed Circuit Board Holders (fig. 4-36). To prevent damage during assembly and inspection, the circuit board should be held by a jig or fixture. This will prevent it from bending, warping, or deforming in any manner. The jig or fixture will permit the circuit board to be held at each end and fixed at any desired position by use of the wing-nut set screws in the shaft bearings.

## 4-17. Printed Circuit Boards-Continued

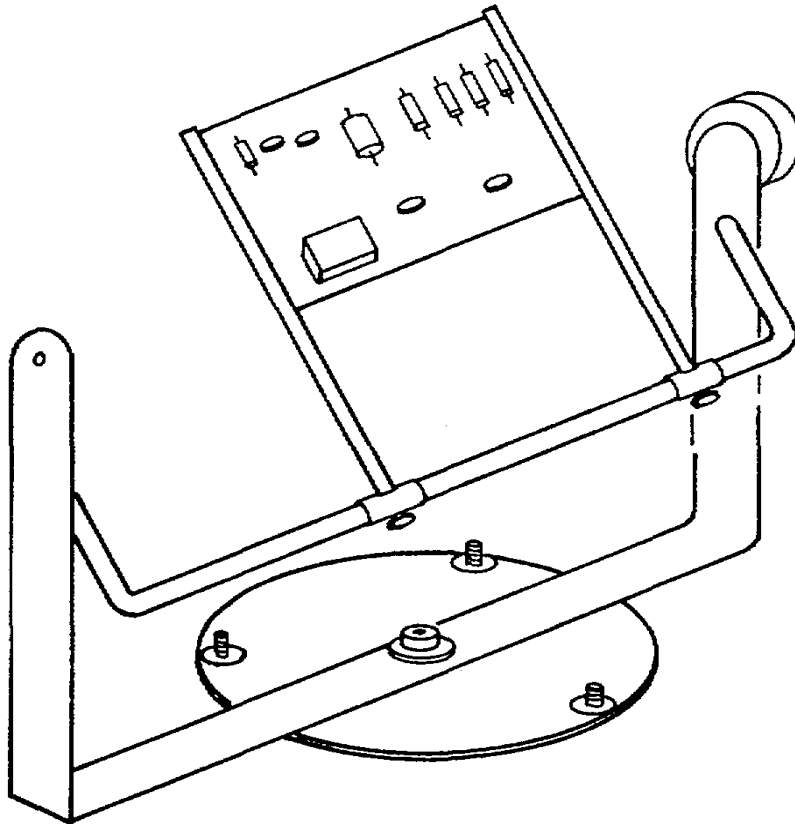

Figure 4-36. Printed Circuit Board Holder

b. Printed Circuit Board Care and Storage. Printed circuit boards should be kept in plastic bags and stored in cardboard boxes. After being wired, inspected, and stamped, the boards should receive an insulative protective coating on both sides.

c. Insulation. On printed circuit boards with conductive patterns on each side, observe the following rules:

- (1) Both connections must be soldered when a component pigtail enters a pad on one side of a board and terminates at a pad or other connection point on the other side.
- (2) Components such as metal case capacitors will be insulated with approved clear tubing when mounted over conductor lines such as shown in figure 4-37.

d. Bending Component Leads. When bending component leads, for positioning on printed circuit boards, observe the following rules:

- (1) Bend component pigtails with a suitable wire bending tool such as wire-bending pliers or tweezers. Long nose pliers may be used if sharp edges are covered with tubing or plastic tape. Flattened, nicked, or damaged pigtails will be rejected.

4-17. Printed Circuit Boards-Continued

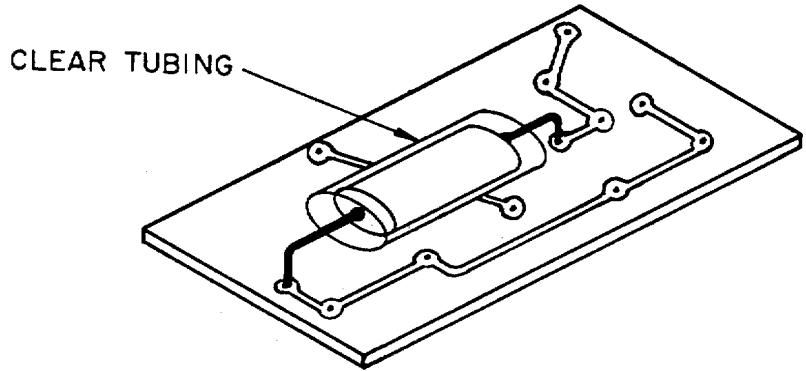

Figure 4-37. Crossing Conductive Lines

- (2) Pigtails should have a minimum clearance of one-sixteenth of an inch between bend and component body as shown in figure 4-38. When making the minimum bend, support end seal of component with wire-bending pliers.

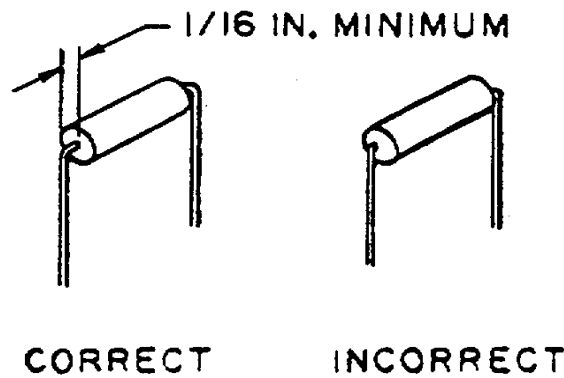

Figure 4-38. Minimum Pigtail Bend

- (3) Extremely sharp 90 degree pigtail bends will not be accepted. All bends should be made with a gradual curve.
- (4) The radius of the bend should be equal to, or greater than twice the lead diameter.
- (5) Component pigtails will extend through the printed circuit boards a minimum of one-sixteenth of an inch to a maximum of one-eighth of an inch and will be clinched flush with the circuit. The bend or clinch must be in the same direction as the conductive line to which the pigtail is attached as shown in figure 4-39. The clinching tool shall be of wood or plastic to prevent damage to the printed circuit or components.

## 4-17. Printed Circuit Boards - Continued

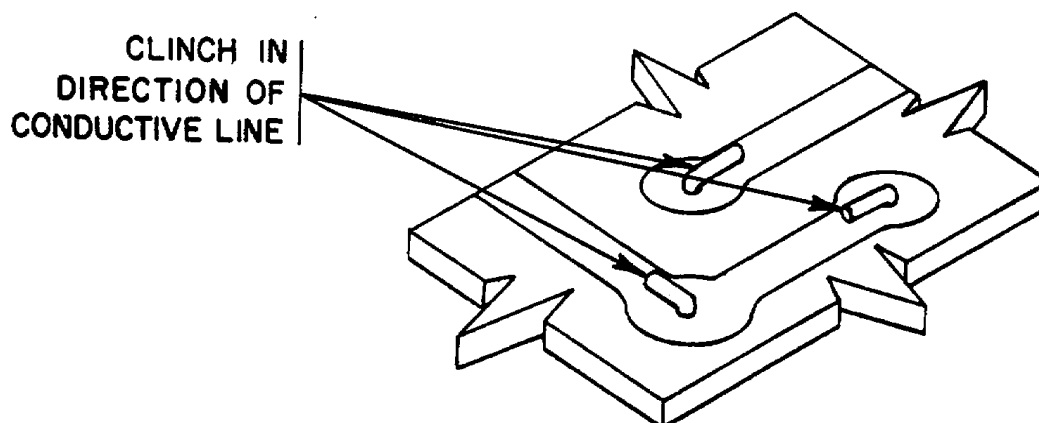

Figure 4-39. Direction of Pigtail Cinch

- (6) Component leads that cannot be bent or clinched flush with the circuit should be properly cleaned and cut to a length that will permit the lead to extend one thirty-second of an inch above the solder pad. Components mounted in this manner shall be secured rigid to the board with a suitable mounting clamp or approved resin.
- (7) With tantalytic capacitors and other components which have welded leads, the bend should be measured from the weld rather than from the component body as shown in figure 4-40.

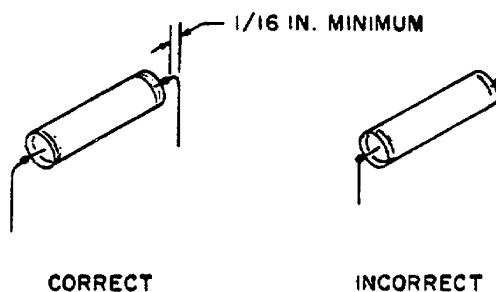

Figure 4-40. Welded Lead with Proper Bend

e. Handling. Whenever practicable, the manual handling of printed circuit pads, terminals, and component leads should be avoided. When manual handling is necessary, wear white gloves to prevent body acids from contaminating the item.

f. Component Mounting (fig. 4-41). Components should be mounted flush with the circuit board unless potted or supported by a suitable retaining clamp.

g. Cleaning. When soldering printed circuits, clean circuit pad with a swab or brush and alcohol. A soft eraser may be used if the alcohol method fails to clean the area properly. After cleaning with an eraser, lightly brush to remove eraser particles.

4-17. Printed Circuit Boards - Continued

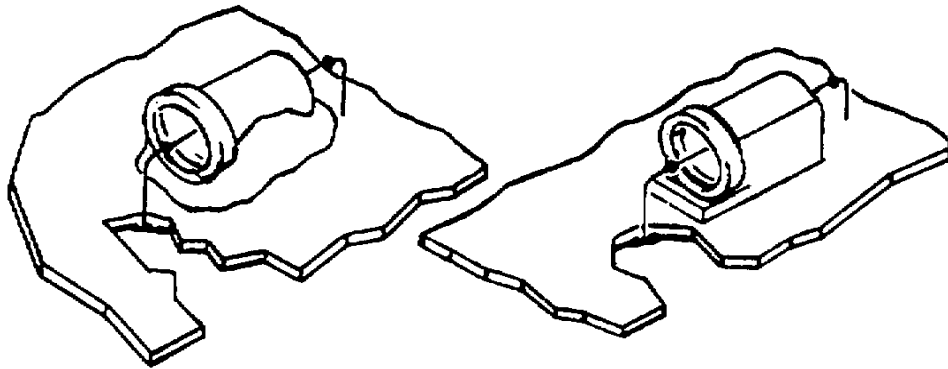

Figure 4-41. Flush Mounting - Examples

h. Soldering. To prevent damage from excessive heat the soldering iron should never be left in contact with the printed-wiring conductor for longer than 5 seconds on paper baseboards, or 8 seconds on fiberglass epoxy baseboards. Excessive heat will cause delamination. If soldering operations exceed the time limits, allow a 30 second cooling period before continuing the soldering operation.

i. Component Weight. Component parts that weigh one-half of an ounce or more should be secured by a suitable mounting bracket or potted with an approved epoxy resin.

j. Mounting and Soldering Terminals. When mounting and soldering terminals to printed circuit wiring boards, the procedures listed below should be followed:

- (1) Drill the pad hole to a diameter that will permit the terminal shank to be pressed through the board by hand. A press fit is not necessary, but the terminal should fit snugly enough to prevent it from falling out.
- (2) Clean the terminal pad with a swab or brush and alcohol. If this method fails to clean the area properly, a soft eraser may be used.
- (3) Press the terminal shank through the board and aline the terminal as shown in figure 4-42.

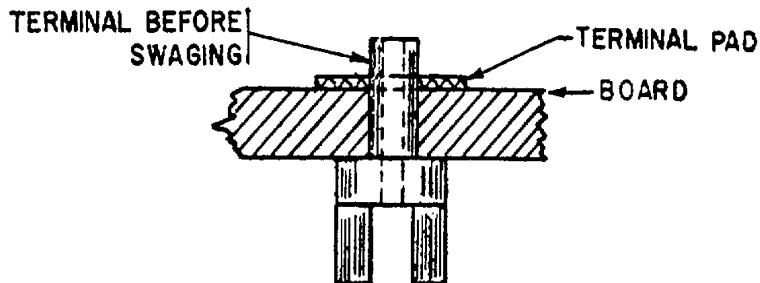

Figure 4-42. Terminal Before Swaging

## 4-17. Printed Circuit Board - Continued

- (4) Make a V or funnel type swage on the terminal. The point of the V swage should enter the terminal shank only far enough to produce a hand tight fit of the terminal as shown in figure 4-43. If solder rings are used, place the ring over the terminal shank before swaging. Solder rings are recommended since they give a more uniform and reliable solder joint.

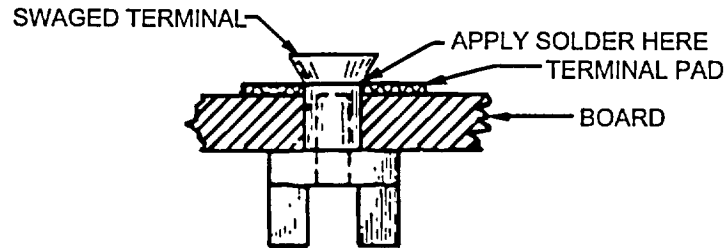

Figure 4-43. Terminal After Swaging

- (4) Place the soldering iron tip over the terminal head, as shown in figure 4-44, and apply solder to the joint where the terminal shank and pad intersect. Allow the solder to flow properly and then remove the soldering iron tip from the terminal head. The solder should completely cover the pad and form a neat uniform joint.

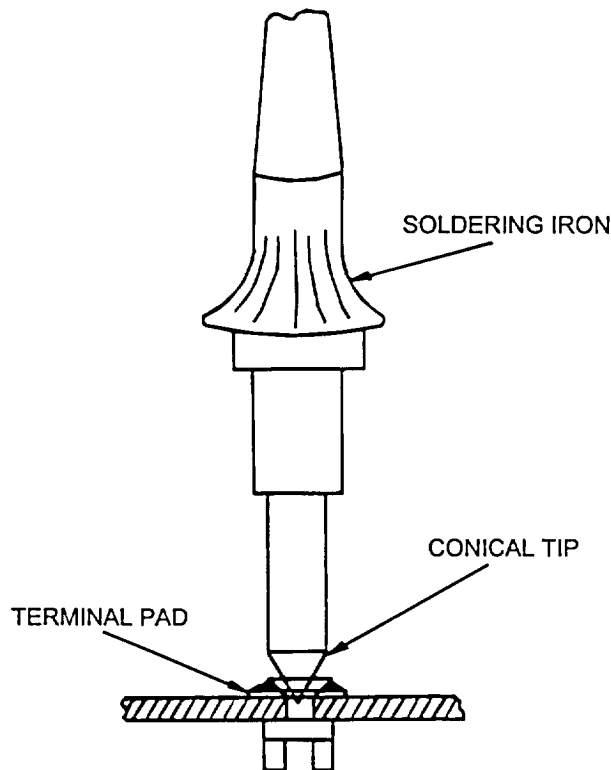

Figure 4-44. Soldering Swaged Terminal

- (4) Carefully clean the soldered joint with alcohol and a medium stiff bristle brush.
- (5) Inspect all joints. If any joint should require resoldering, add a small amount of new solder after reheating the joint.

## 4-17. Printed Circuit Board - Continued

j. Flat Pack and Dual-In-Line Pack (DIP) ICs.

(1) Flat Pack. They are planar mounted on the surface of the board to form lap solder joint connections. The specification for round leads will be observed with these additions:

- (a) The leads will contain two distinct bends at an approximate angle of 45°
- (b) The leads will contact the solder pad from the second bend to the lead tip
- (c) The contact area will not overhang the edge of the solder pad
- (d) The contact area of the lead will be one-half the length of the solder pad

(2) Dual-In-Line Packs (DIPs). They are mounted through the surface of the board and soldered in place. The specification for round leads will be observed with these additions:

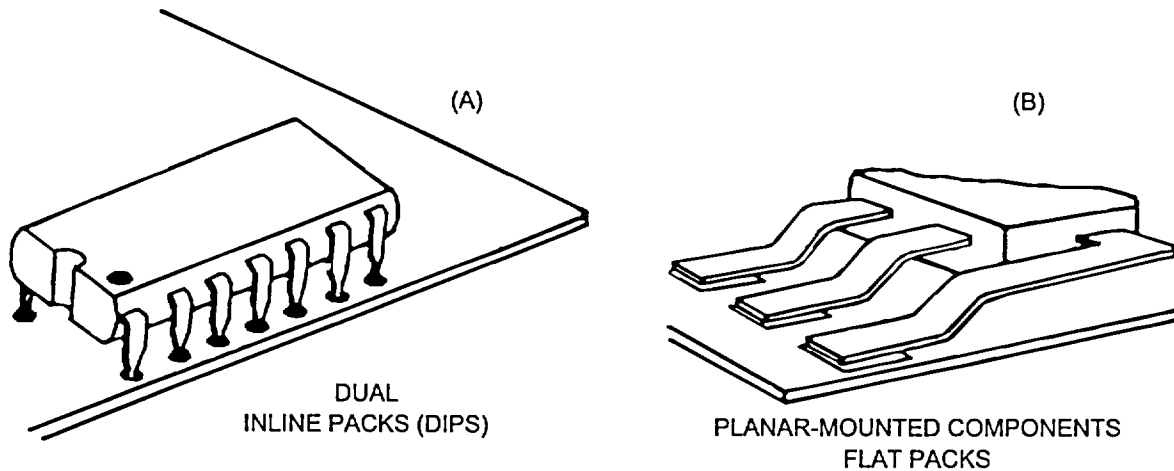

Figure 4-44.1. Typical Planar Mounted IC

- (a) Form the leads by pressing both rows of leads down onto a flat surface with enough pressure to obtain the correct angle. Another method is the use of a DIP clip that holds the leads inward for installation.
- (b) Clinch the two leads on opposite corners to hold the IC in place.
- (c) Apply iron tip to one side of the joint touching the lead and pad area, while applying solder to the opposite side.
- (d) Apply iron until solder pool flows into hole to produce a smooth, concave fillet.

4-17. Printed Circuit Boards - Continued

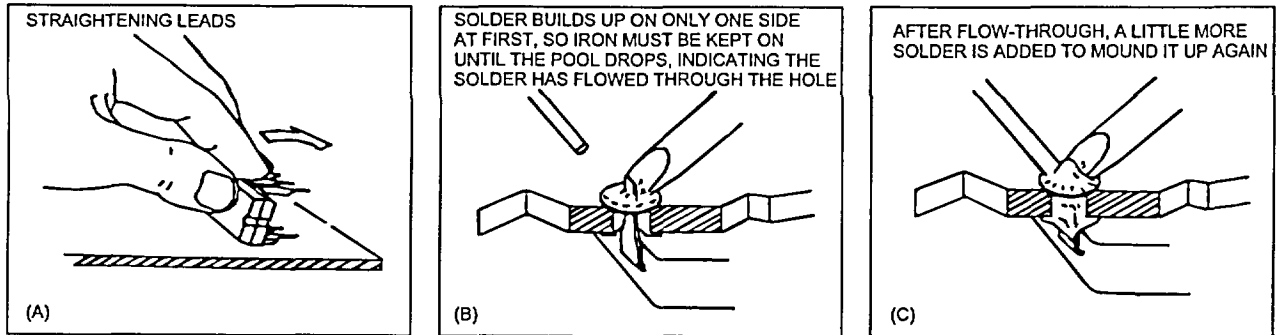

Figure 4-44.2. DIP Mounting and Soldering

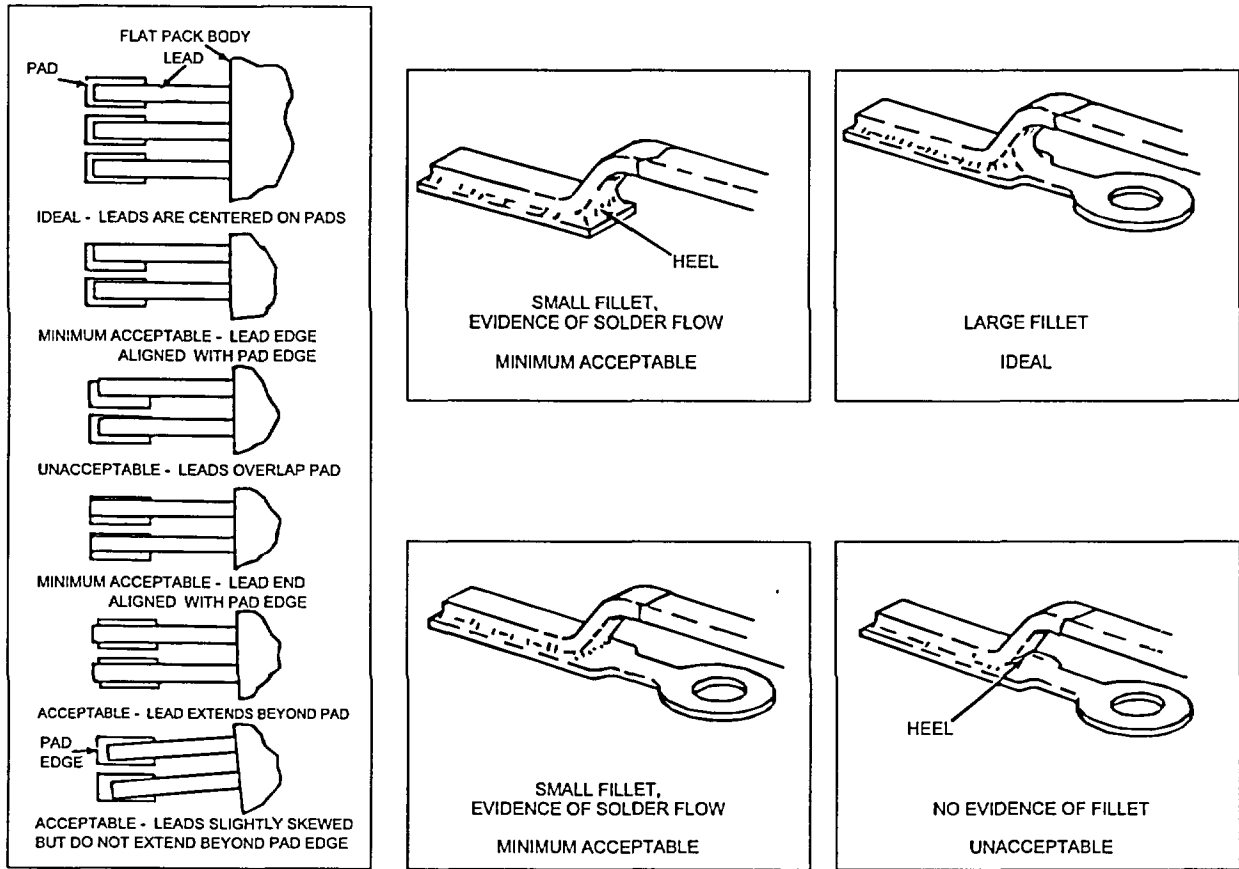

Figure 4-44.3. Typical Flat Pack Positioning and Installation



4-17. Printed Circuit Boards - Continued

j. Damaged Conductor Repair Procedure for Single Layer Boards.

(1) Solid Wire. All breaks in wire conductors must be repaired so that no reduction in cross section thickness will result. Table 4-8 provides equivalent conductor widths and solid wire diameters. It is assumed that the broken conductor is of the 2-ounce type which provides a margin of safety in selecting the equivalent wire diameter. Proceed as follows:

- (a) Measure the conductor width and select the equivalent or next larger diameter solid wire.

Table 4-8. Proper Wire Selection

Conductor width (2-oz.)	Equivalent solid wire diameter
0.010	#34(0.006)
0.015	#32(0.008)
0.020	#31(0.009)
0.031	#29(0.011)
0.062	#26(0.016)
0.125	#23(0.023)

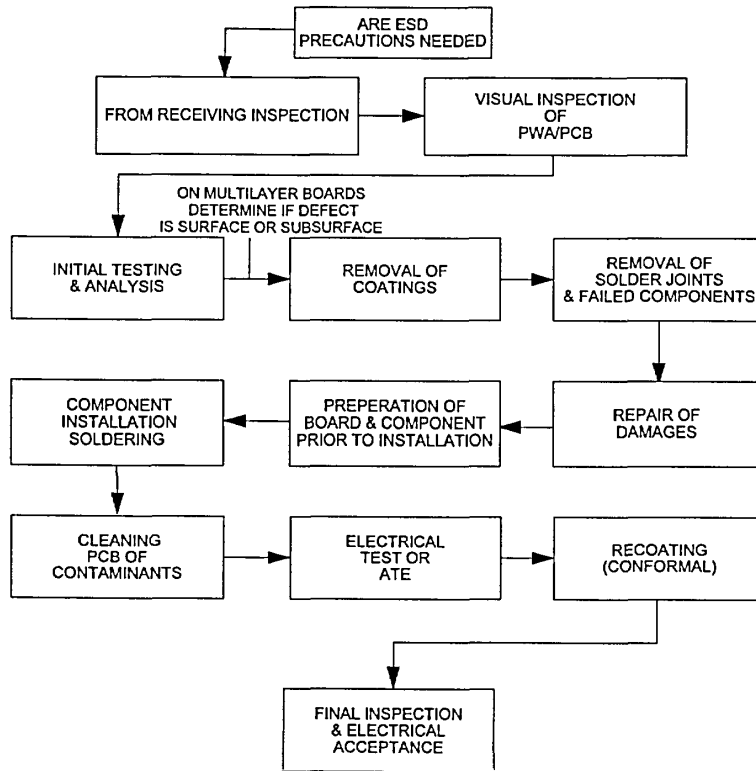

Figure 4-44.4. Repair-Sequence Flow Chart

## 4-17. Printed Circuit Boards - Continued

(b) Follow the foil repair procedure in (2) below.

## (2) Foil Repair Procedure.

- (b) Choose a matching foil, copper, aluminum, wrought copper, or gold ribbon.
- (c) Measure the conductor width and select the proper size for repair.
- (d) Cut foil length 1/4 inch longer than the break.
- (e) Prepare surface to be repaired by solvent or abrasion.
- (f) Lap reflow solder along the center of the conductor.
- (g) Inject epoxy filler under repair foil with a hypodermic needle.
- (h) Clean residue from the repair area.
- (i) Recoat the solder joint with conformal coating.

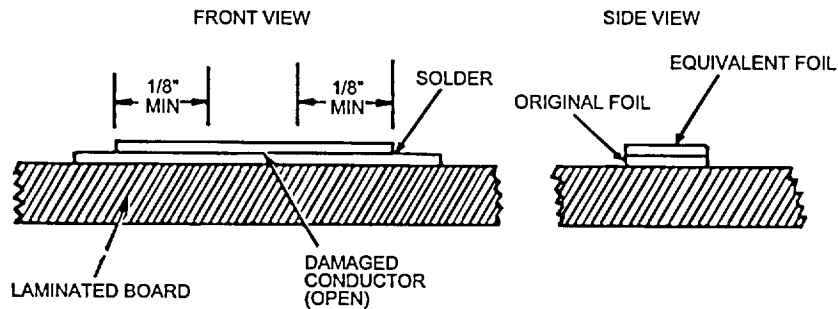

Figure 4-44.5. Foil Repair

(1) Conductor Repair Procedures for Multilayer Boards. Use the parallel gap welding technique to repair defective printed circuit conductors on double-sided and multilayer boards. This method can be used to repair breaks on both inner and outer layers. Refer to the procedure below:

- (a) Locate break and chisel or mill away base until enough conductor is exposed to perform a weld (0.1 inch of conductor on each side of the break)
  - (b) Clean conductor to a shiny color for a proper weld.
  - (c) Select a gold ribbon the same width as the conductor being repaired (preferred material).
  - (d) Position gold ribbon over the break.
  - (e) Apply a spot weld on each side of break with a parallel gap welder.
    - 1 Control the interelectrode spacing for consistent results.
    - 2 Vary the spacing according to the materials and the bond to be produced.
    - 3 Fit the electrodes tight against the work for good electrical and thermal conductivity.
    - 4 Use a spacing at least 1-1/2 times the thickness of the upper material.

## 4-17. Printed Circuit Board - Continued

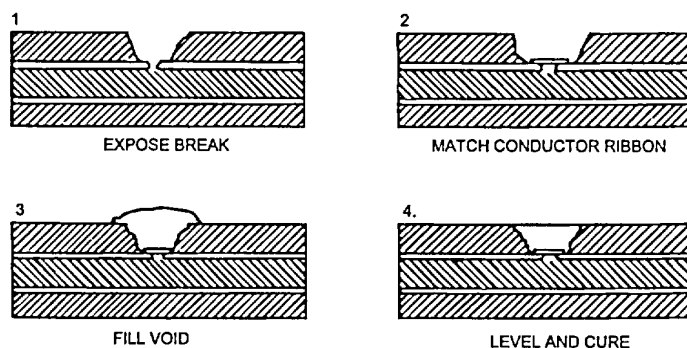

Figure 4-44.6. Damaged Conductor (Trace) Repair

- (a) Fill the void with a compatible epoxy mixture and allow to cure after the welding is completed.
- (b) Level the cured epoxy mixture with a chisel or mill to match the surface finish of the printed circuit board.

m. Flexible Circuits. Flexible circuits/cables are designed to provide efficient and practical methods for making connections and utilizing space. The etched circuit is composed of flat copper conductors enclosed in insulating materials. The conductor to, Isolation bonding provides a barrier against moisture and gases, and is very durable. The product may be bent, coiled, twisted, and formed to follow the various outlines of multiple systems. Assemblies may be hinged, pulled-out and flexed for maintenance or inspection even when still in operation. Flex circuitry/cables provide high reliability with less distortion or noise than conventional wiring. In addition, various methods can be used for final assembly, such as, welding and soldering.

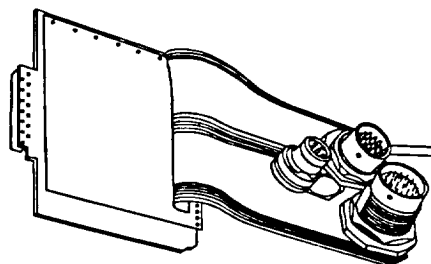

Figure 4-44.7. Flexible Circuit

l. Multiwire Technology. A multiwire PWA/PCB is a computer tape controlled series of conductor wires laid down on an adhesive coated double-sided printed circuit board. The two sides of the board are used for voltage and ground plane applications. The voltage and ground planes are etched to both sides providing a semicured base for laying in the conductor wires. The circuit is formed by using a pressure head, that imbeds the conductor wires in the adhesive. Holes are then drilled in the board followed by the plating of these holes. Multiwire PWA/PCBs can be hand, wave, or dip soldered using conventional soldering techniques. Multiwire printed circuit boards are recommended for high frequency applications.

m. Additive Plating Technology. Additive plating may be defined in this manner: Additive plating is a process whereby printed circuit boards are manufactured by selective depositing of a conductor material on an unclad base material (no conductor material anywhere on the base material). The circuit is developed by applying a background negative-image resist pattern, which leaves conductor areas and holes to be plated through, exposed for metal deposit. Additive plating is an economy oriented process.

n. Leadless Components. A new trend in the manufacture of PCBs is to use so-called "LEADLESS COMPONENTS." These are passive components such as resistors or capacitors which are made on semiconductor substrate material and are greatly reduced in size. They do have axial leads, however, and are removed and replaced in a similar manner to flat pack ICs (para 4-17.k.1). Use of leadless components can reduce a multilayer board to a single layer and reduce its size by as much as one third.

## 4-18. Resistance Soldering.

a. General. In electrical resistance soldering, the heat is generated directly in the metal area to be soldered by using a pair of carbon electrodes that grip the metal. An electrical current is passed from one electrode, through the metal and into the other electrode and causing the metal to heat up.

b. Advantages. Resistance soldering is well adapted to any of the following conditions.

- (1) To eliminate a flame hazard and oxidation.
- (2) Where the port is inaccessible for soldering irons.
- (3) Where it is desired to restrict the heat to a selected portion of the assembly.

c. Resistance Soldering Equipment Setup (fig 4-45). Set up the resistance soldering unit as follows:

- (1) Plug the transformer power cord (9) into the foot pedal (8)
- (2) Connect cord set (4) to cord set terminals (3).
- (3) Plug power cord (7) into a wall receptacle.
- (4) Place ON-OFF switch (2) to the ON position and press down on foot pedal (8) ; power light will come on.
- (5) Release foot pedal (8) ; power light will go out.
- (6) Turn transformer select knob (1) to the desired output setting.

d. Resistance Soldering A Cup Terminal (Fig. 4-45 and 4-46). A procedure for properly soldering a cup terminal is as follows:

- (1) Strip insulation sleeving from the wire and clean the center conductor with alcohol.
- (2) Tin the wire as described in paragraph 4-16.
- (3) Place cup terminal in a vise at an approximate 60 degree incline from a straight up position.

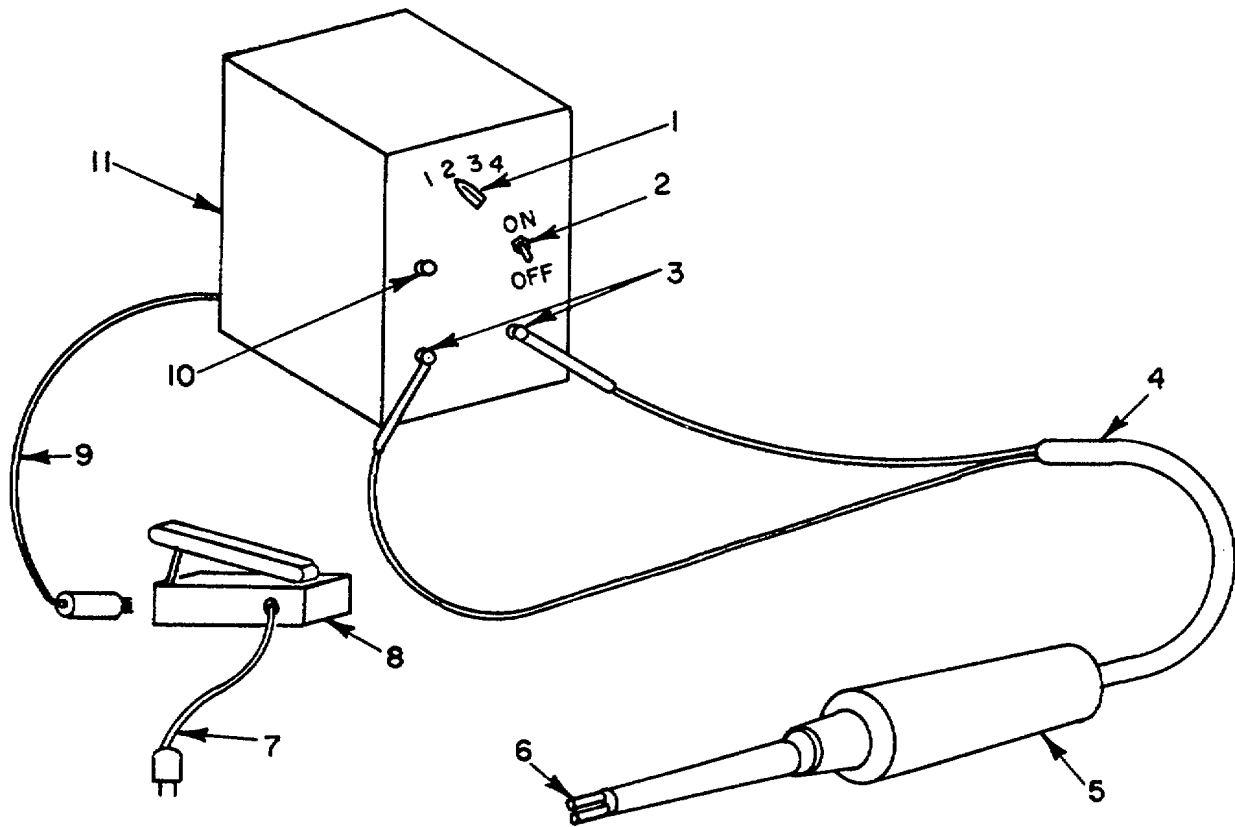

KEY to figure 4-45:

- |                            |                           |
|----------------------------|---------------------------|
| 1. Temperature select knob | 7. Power cord             |
| 2. ON-OFF switch           | 8. Foot pedal             |
| 3. Cord set terminals      | 9. Transformer power cord |
| 4. Cord Set                | 10. Power light           |
| 5. Hand piece              | 11. Transformer unit      |
| 6. Electrodes              |                           |

Figure 4-45. Resistance Soldering Unit

## 4-18. Resistance Soldering - Continued

## CAUTION

Always release the foot pedal before placing the electrodes on the work surface or removing the electrodes from the work surface. This will prevent arcing and damage to the equipment.

- (4) Place electrodes in contact with the bottom of the cup cavity. Press foot pedal (8, fig. 4-45) while applying solder to cup and pre-fill cavity with solder.
- (5) Release foot pedal (8, fig. 4-45) and remove electrodes from cup terminal. Allow solder to cool and clean flux residue from cup terminal.
- (6) Place electrodes in contact with the bottom of the cup cavity. Hold prepare conductor, with a heat shunt, above the cup opening.
- (7) Press down on foot pedal (8, fig. 4-45) and wait for solder in the cup terminal to melt.
- (8) Insert conductor into the cup terminal and allow conductor to heat.
- (9) Release foot pedal (8, fig. 4-45) and remove electrodes from cup. Allow solder to cool completely before removing heat shunt.
- (10) Remove any flux residue from solder joint using alcohol.

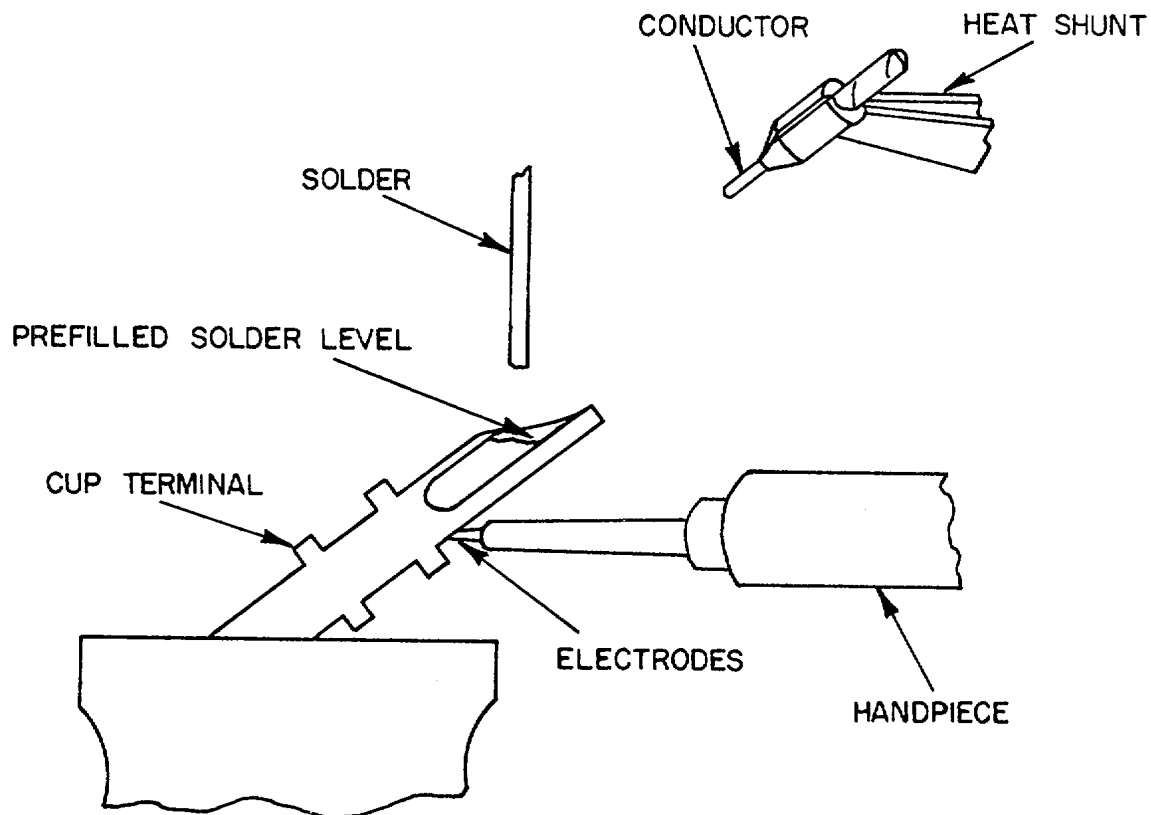

Figure 4-46. Resistance Soldering a Cup Terminal.

## 4-19. Induction Heat Soldering

- a. General. The induction heat method of soldering employs a principle of heat application totally different from any conduction or convection process discussed earlier. In this method, heat is not actually applied to the assembly to be soldered, but rather, heat is generated within the assembly itself by exposure to an electromagnetic field.
- b. Induction Heat Soldering Equipment. The induction heat soldering equipment consists of the following:
- (1) A high-frequency generator to produce a high-frequency alternating current.
  - (2) A water-cooled metal coil, attached to the high-frequency generator, to carry the high frequency alternating current that produces an electromagnetic field within the coil.
- c. Uses. The induction method of soldering is very useful in the soldering of:
- (1) Large or massive pieces of metal.
  - (2) Small metal parts where it is desired to confine the heat to some particular section of the assembly.
  - (3) Soldering multiple metal assemblies at one time that would become oxidized if heated with a flame or torch.
  - (4) Soldering units where the point of soldering could not be reached by the tip of a soldering iron.
  - (5) Chain soldering, where the parts are placed on an endless belt which travels through the electromagnetic field at a constant rate of speed.
- d. Advantages. The main advantages for using induction heat soldering compared to conduction or convection methods are as follows:
- (1) The metal is quickly and efficiently heated at the exact point where it is needed.
  - (2) The metal does not warp, discolor or oxidize.
- e. Selecting Flux. Select a stable and fairly concentrated flux which will withstand the sudden influx of heat without decomposition. Concentrated chloride fluxes or resin fluxes are best adapted to induction heat soldering.

## Section IV. USE OF ABRASIVES AND FILES

## 4-20. Abrasive Processes.

- a. General. Processes and materials discussed in this section, use abrasive grains for shaping work pieces. Abrasive grains are hard crystals either found in nature or manufactured. The most commonly used materials are aluminum oxide, silicon carbide and diamond. Other materials such as garnet, zirconia, and glass are used as abrasives for some applications.

4-20. Abrasive Processes - Continued

- a. Forms of Abrasives. Abrasive products are used in three basic forms:
  - (1) Bonded, to form a solid shape tool such as disks, cylinders, rings or sticks.
  - (2) Coated, on backings made of paper or cloth in the form of sheets, strips or belts.
  - (3) Loose, held in some liquid or solid carrier, (for lapping and polishing) or propelled by centrifugal force such as air or water against the work surface (blast cleaning).
- b. Application for Abrasives. Application for abrasives are multiple and varied.
  - (1) Cleaning, of surfaces. Coarse removal of excess material.
  - (2) Shaping, such as tool sharpening.
  - (3) Surface finish improvement, primarily as in lapping, honing, and polishing.

4-21. Lapping.

- a. General. Lapping is an operation for removing a small amount of metal with an abrasive compound either by hand or machine. Lapping produces a smooth, but not necessarily polished, surface that is not usually obtainable through ordinary machine and hand operations such as turning, thread cutting, filing. Lapping must be performed, therefore, to properly finish such bearing surfaces as sleeves, worm gears, and eyepieces. Machine lapping is not normally within the field of work for the instrument repairperson as it is used chiefly in production work.
- b. Lapping Compound. The abrasive mixture used in the lapping process is known as the lapping compound and must be mixed by the instrument repairperson. It is composed of artificial abrasives such as silicon carbide, manufactured boron carbide, or manufactured aluminum oxide mixed with oil, grease, or water.
- c. Lapping Procedures. In the lapping process, select a grade of compound that is best suited for the job. Select a compound which will resist the tendency to embed itself in to the material being lapped. The following list will be useful in making such a choice:

Metal	Compound (grade)
Steel on steel	Medium and/or fine
Steel on brass	Medium and/or fine
Brass on brass	Medium and/or fine
Aluminum on aluminum	Fine

- (1) Apply the compound sparingly to the parts to be lapped, then work the parts together until they are perfectly mated. Frequent inspection should be performed to prevent the removal of excess material, thus causing possible spoilage. After lapping has been accomplished, and before each inspection, the parts must be washed off thoroughly. Cleaning solvent such as mineral spirits or paint thinner may be used. The washing-off process must remove the lapping compound; otherwise the cutting action will continue as the parts are worked together in use.



## 4-21. Lapping- Continued

- (1) The fact that a movement binds or chatters is not always an indication that lapping is necessary. Disassemble, wash, and thoroughly inspect the parts before lapping. It is possible that inspection will reveal a small burr which may be easily removed with a file, scraper, or oilstone. A good cleaning, followed by proper lubrication, may also be enough to smooth out a movement.

b. Lapping, Using A Surface Plate (fig 4-47). Often it becomes necessary to insure that the mating surface of a part is flat before assembly into a piece of equipment. An example of this would be in the use of the retainer-8267736 used in the M145 Telescope Mount. By using a surface plate, the retainer can be lapped to a flat surface as described below.

- (1) Position a surface plate on a suitable work surface.

**NOTE**

**Selection of abrasive material used in the lapping process will depend upon the material makeup of the item being lapped.**

- (1) Select a piece of emery cloth, 8 inches by 11 inches, and cover the back side of the emery cloth with an adhesive material (two sided tape or other suitable adhesive that will secure emery cloth to the surface plate).

**NOTE**

**Emery cloth must lay flat against the surface plate with no bends or tears allowed in the emery cloth**

- (1) Position the emery cloth (with the adhesive side facing the surface plate) on the center of the surface plate and press firmly against the emery cloth to secure in place.
- (2) Place retainer, with the side to be lapped, on the emery cloth and begin the lapping process. Apply even, firm pressure on the retainer and move retainer in a figure eight fashion across the emery cloth.
- (3) After making two or three passes across the emery cloth, remove the retainer and inspect the side being lapped. If the retainer is flat, abrasive marks will appear across the entire surface of the retainer. Intermittent abrasive marks across the surface being lapped indicates the need for further lapping.
- (4) If further lapping is necessary, repeat steps (4) and (5) above until a flat surface is obtained as described in step (5).
- (5) After the lapping process is completed, wash the retainer in Dry Cleaning Solvent to remove all abrasive particles.

## 4-21. Lapping - Continued

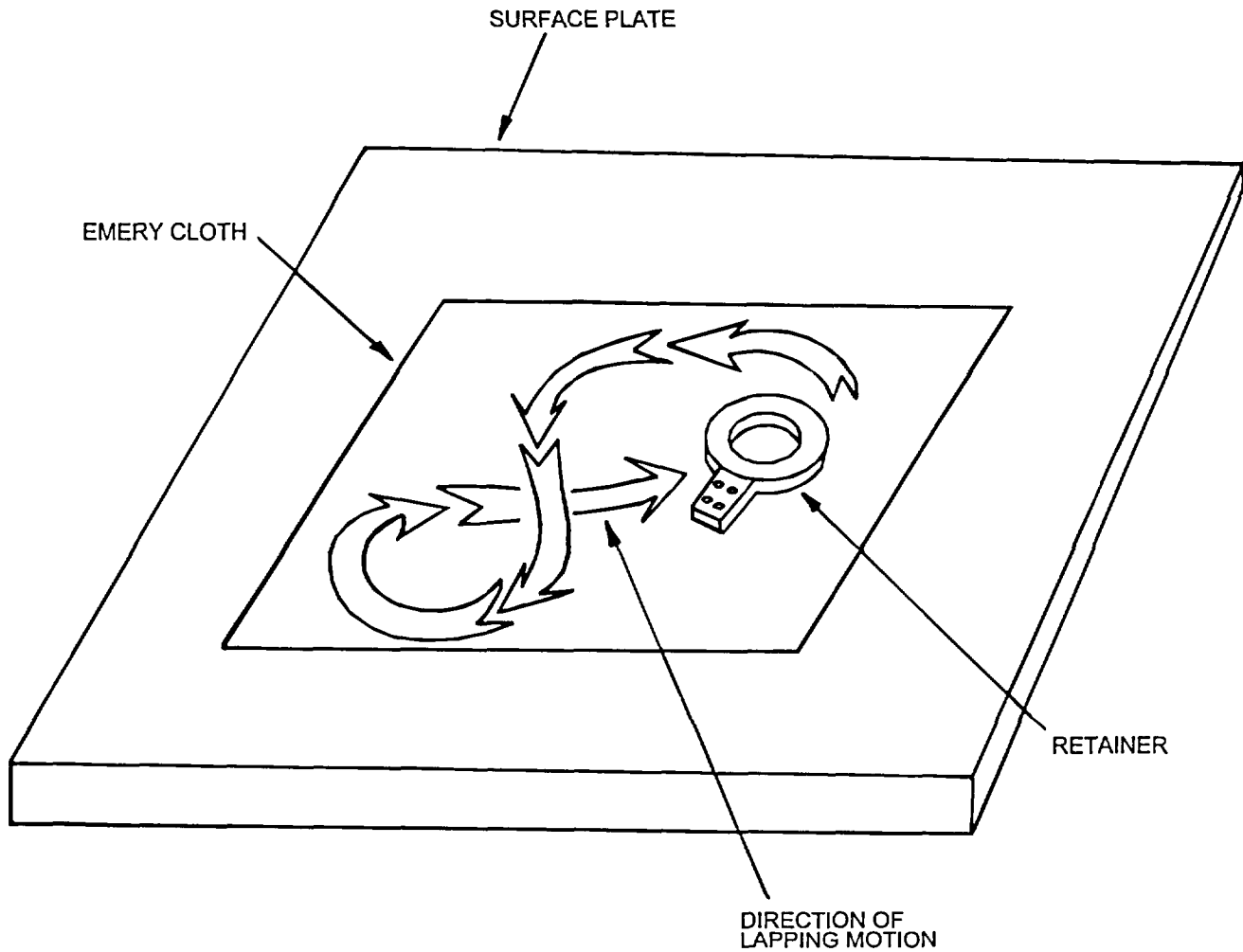

Figure 4-47. Lapping on a Surface Plate

## 4-22. Files.

a. General. This section contains a general discussion for proper selection of a file and method of filing. For a more detailed discussion about files, refer to TM 9-243, Use and Care of Handtools and Measuring Tools.

b. Selecting Proper Files. The following steps are recommended for selecting a proper file:

- (1) For heavy, rough cutting, a large coarse, double-cut file is best.
- (2) For finishing cuts, use a second or smooth cut, single-cut file.

**4-22. Files - Continued**

- (3) When working on cast iron, start with a bastard cut file and finish with a second cut file.
- (4) When filing soft metal, start with a second cut file and finish with a smooth cut file.
- (5) When filing hard steel, start with a smooth cut file and finish with a dead smooth file.
- (6) When filing brass or bronze, start with a bastard file and finish with a second or smooth cut file.
- (7) When filing aluminum, lead, or babbitt metal, use a bastard cut curved-tooth file.
- (8) For small work use a short file, for medium sized work use an 8 inch file, for large work use a file that is most convenient.

c. Method of Filing (fig. 4-48). The following procedure is recommended when filing:

- (1) Clamp the work securely in a vise so that the area to be filed is parallel to and projecting slightly above the vise jaws.
- (2) Hold the file handle in one hand, thumb on top, and hold the tip of the file with the fingers of the other hand, as shown in figure 4-48.

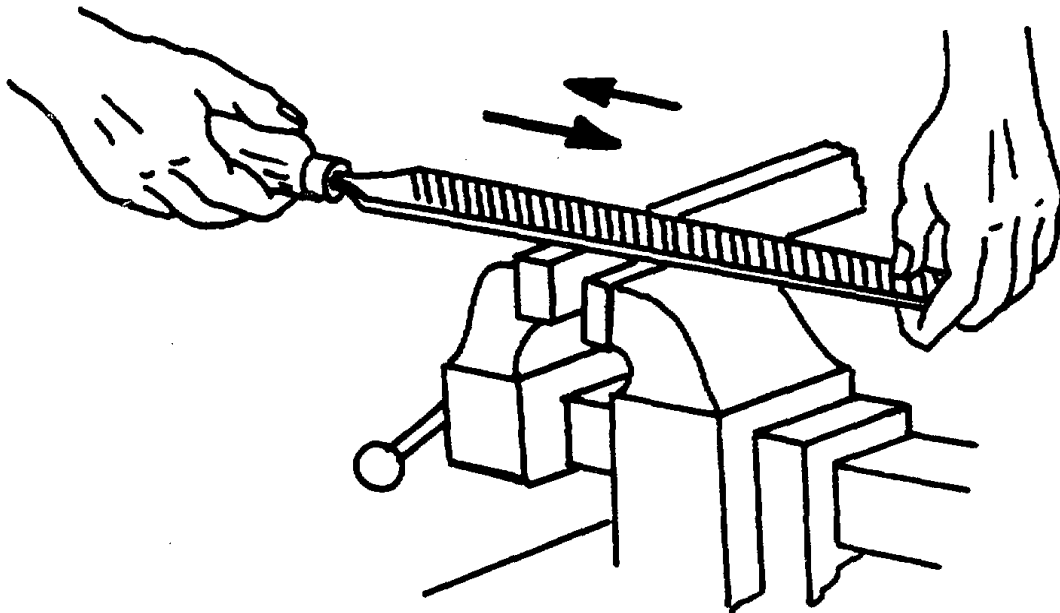

Figure 4-48. Normal Filing Procedures

**4-22. Files - Continued**

- (3) When filing hard metals, apply pressure on the forward stroke only. The file should be lifted from the work on the return stroke to prevent the teeth from becoming dull. When filing soft metals, pressure on the forward and return stroke will help keep the cuts in the file clean of waste metal and will not dull the teeth.
- (4) Use a rocking motion when filing round surfaces.
- (5) When using a new file, too much pressure or force may cause the teeth to break off. File slowly, lightly, and steadily. Too much speed and too much pressure causes the file to rock and will round off the corners of the work.

**4-23. Removing Nicks and Burrs.**

a. General. Burrs are thin edges or rough spots left on metal surfaces and are common on outside and inside screw threads. Nicks are small grooves or cuts in the metal surface and can form either ridges, uneven surfaces or burrs.

b. Nick and Burr Removal. The following are suggested ways of removing nicks and burrs:

- (1) To remove burrs from straight edge, hold a flat file at an angle to the edge as shown in figure 4-49, and move the file back and forth along the edge until the edge is smooth and even.

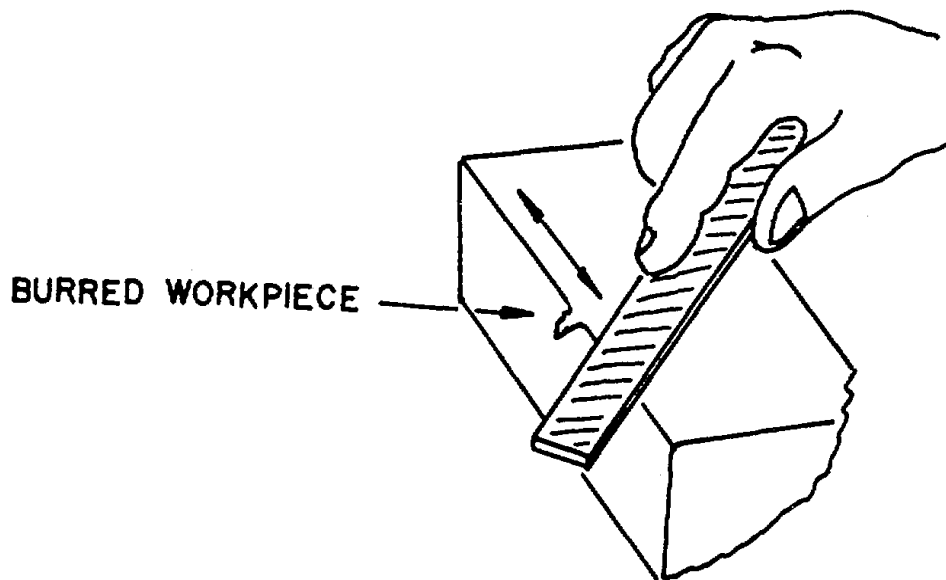
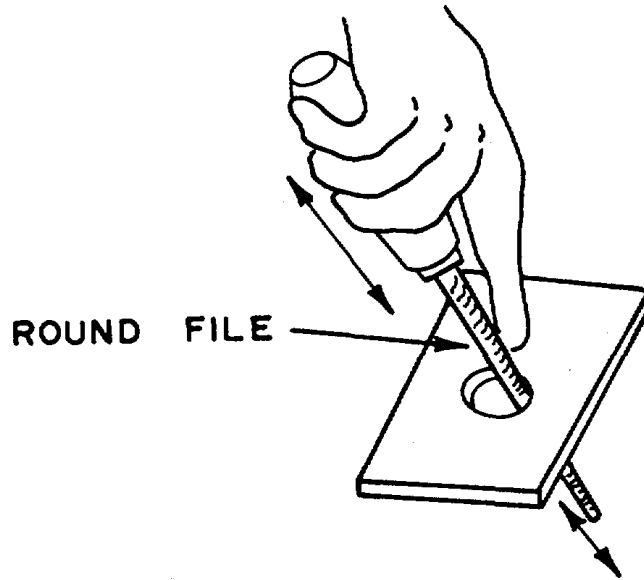

Figure 4-49. Using a Flat File.

**4-23. Removing Nicks and Burrs - Continued**

- (2) To remove burrs from an edge which is rounded, use a round fine-cut file in a sawing action along the edge as shown in figure 4-50.



*Figure 4-50. Using a Round File*

- (3) If the motion in step (2) is not possible, use a careful circular motion along the edge of material.
- (4) To remove burrs from machined surfaces, use a honing stone and pass across burr in a back and forth motion as shown in figure 4-51.

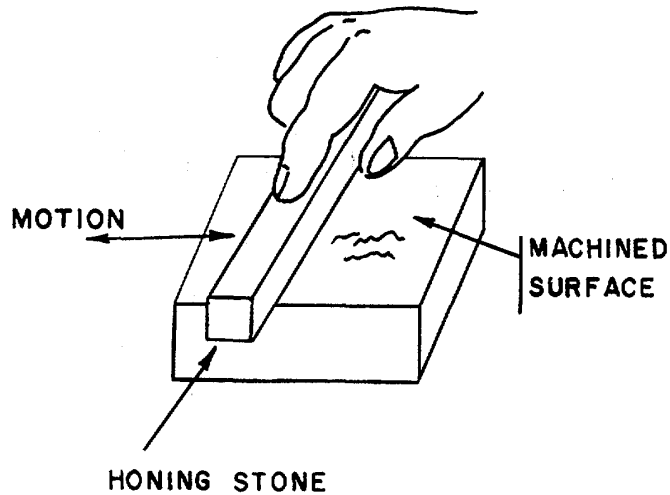

*Figure 4-51. Removing Burrs From a Flat Surface*

**4-23. Removing Nicks and Burrs - Continued**

- (5) After removing all nicks, burrs, and bumps rub the surface with fine abrasive cloth until the surfaces are smooth.

**4-24. Grinding Chipped Windows.**

Glass windows may become chipped around the edges during normal usage or disassembly. The sharp edges can cause cuts to personnel and damage to equipment and therefore must be removed.

- (1) Use a round type sharpening stone to rub back and forth over the chip as shown in figure 4-52.
- (2) Use only light pressure of the stone on the glass. Rotate the stone as you rub it back and forth on the glass.
- (3) Every few minutes, inspect the chip for smoothness of edges. When all sharp edges are gone repeat the process on other chips on the window edge if they are present.

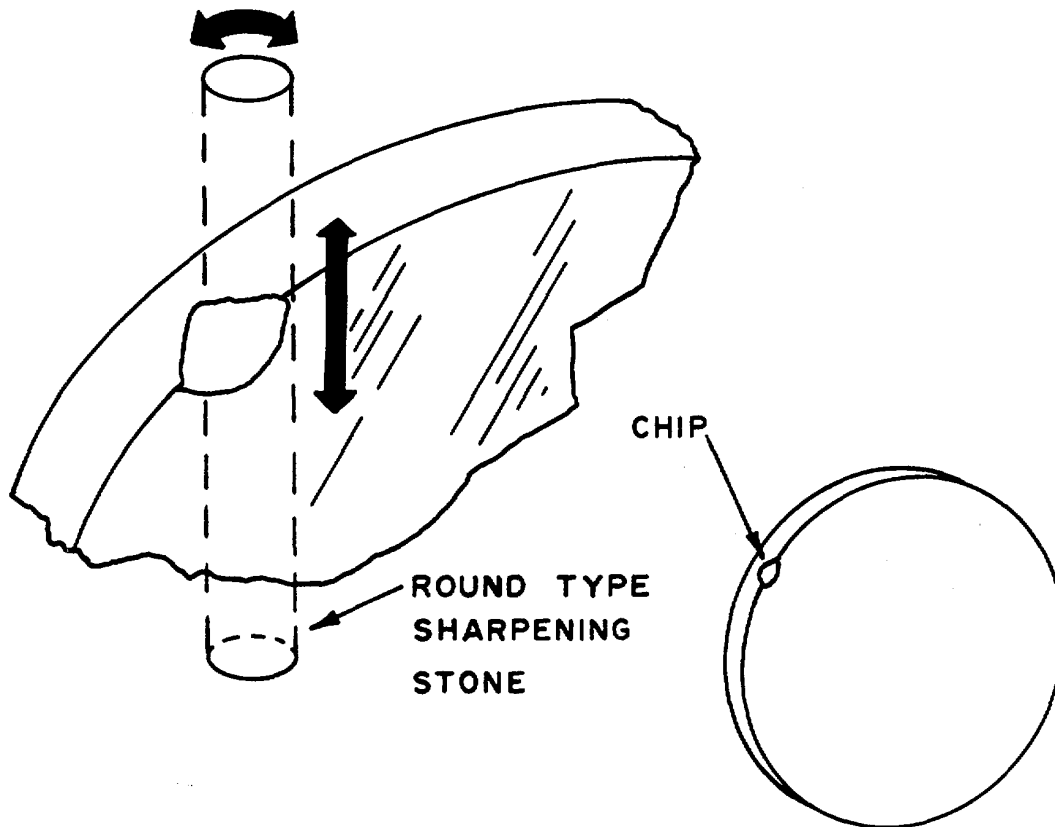
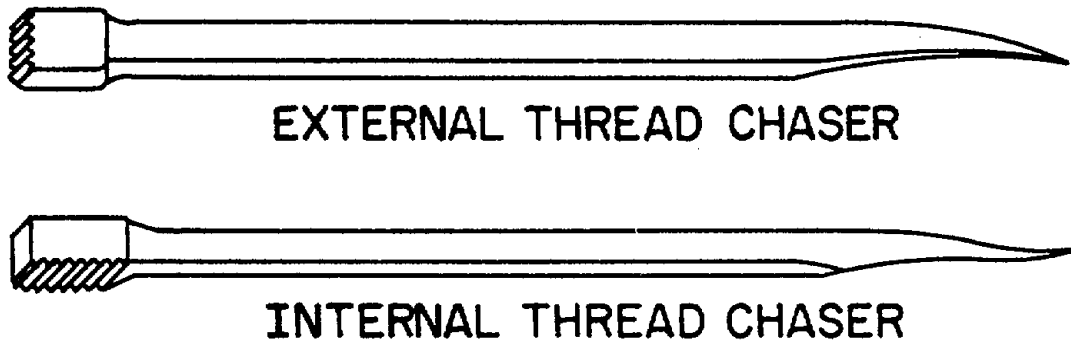

Figure 4-52. Grinding Window Chips

**4-25. Thread Chasers.**

a. Purpose. Thread chasers are used to rethread damaged external or internal threads.

b. Types of Thread Chasers. Thread chasers (fig. 4-53) are threading tools that have several teeth. These tools are available to chase threaded parts having standard threads. The internal thread chaser has its cutting teeth located on a side face. The external thread chaser has its cutting teeth on the end of the shaft. The handle end of the tool shaft tapers to a point.



*Figure 4-53. Thread Chasers*

c. Use of Thread Chasers. Select the proper thread chaser for the job. You must know the number of threads per inch on the work. Simply use a rule to measure off a distance of one inch and count the number of threads in the measured distance. If screw pitch gages are available, use them to determine the number of threads per inch. Secure the work in a vise or hold the work in one hand. Hold the chaser in the other hand and run it around the threaded section. Hold the chaser firmly so that the cutting teeth are parallel to the threads in the work as shown in (fig. 4-54). The cutting action will follow the previously cut threads and restore the damaged portion.

d. Care of Thread Chasers. Never attempt to sharpen thread chasers yourself. This is a highly specialized cutting process which involves precision work on hard tool steel of a shape altogether not suited for simple stroking on an oilstone. Store chasers carefully when not in use. Coat with a light film of oil and store individually so that the cutting edges do not touch other metal. For long periods of storage, coat chasers with a rust-preventive compound and store in a dry place.

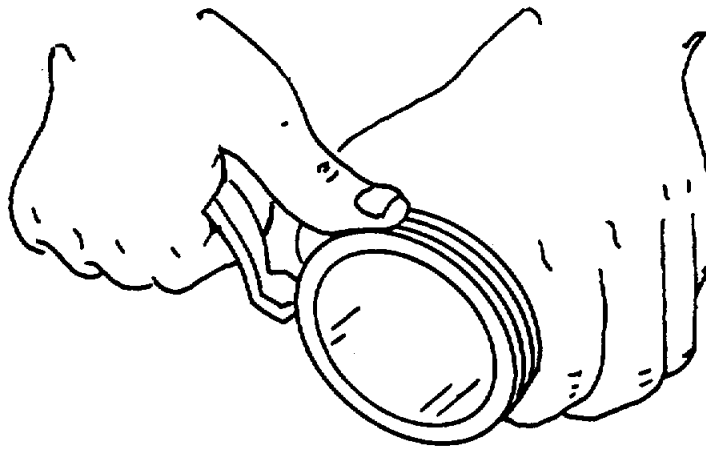

**EXTERNAL**

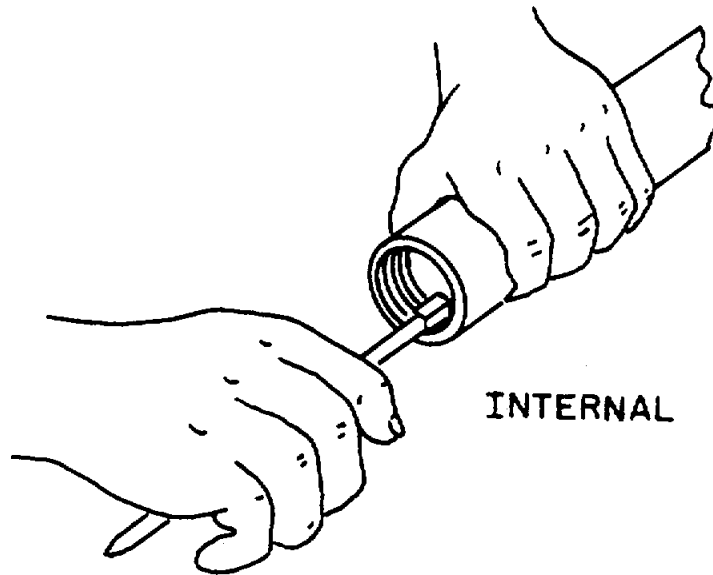

**INTERNAL**

*Figure 4-54. Using Thread Chasers*



4-26. Standard Drill Sizes to Decimal Equivalents

Table 4-9. Standard Drill Sizes

Drill Size	Dec Equiv	Drill Size	Dec Equiv	Drill Size	Dec Equiv	Drill Size	Dec Equiv
80	.0135	43	.089	8	.199	25/64	.3906
79	.0145	42	.0935	7	.201	X	.397
1/64	.0156	3/32	.0938	13/64	.2031	Y	.404
78	.016	41	.096	6	.204	13/32	.4062
77	.018	40	.098	5	.2055	Z	.413
76	.020	39	.0995	4	.209	27/64	.4219
75	.021	38	.1015	3	.213	7/16	.4375
74	.0225	37	.104	7/32	.2188	29/64	.4531
73	.024	36	.1065	2	.221	15/32	.4688
72	.025	7/64	.1094	1	.228	31/64	.4844
71	.026	35	.110	A	.234	1/2	.500
70	.028	34	.111	15/64	.2344	33/64	.5156
69	.0292	33	.113	B	.238	17/32	.5312
68	.031	32	.116	C	.242	35/64	.5469
1/32	.0312	31	.120	D	.246	9/16	.5625
67	.032	1/8	.125	1/4 (E)	.250	37/64	.5781
66	.033	30	.1285	F	.257	19/32	.5938
65	.035	29	.136	G	.261	39/64	.6094
64	.036	28	.1405	17/64	.2656	5/8	.625
63	.037	9/64	.1406	H	.266	41/64	.6406
62	.038	27	.144	I	.272	21/32	.6562
61	.039	26	.147	J	.277	43/64	.6719
60	.040	25	.1495	K	.281	11/16	.6875
59	.041	24	.152	9/32	.2812	45/64	.7031
58	.042	23	.154	L	.290	23/32	.7188
57	.043	5/32	.1562	M	.295	47/64	.7344
56	.0465	22	.157	19/64	.2969	3/4	.750
3/64	.0469	21	.159	N	.302	49/64	.7656
55	.052	20	.161	5/16	.3125	25/32	.7812
54	.055	19	.166	O	.316	51/64	.7969
53	.0595	18	.1695	P	.323	13/16	.8125
1/16	.0625	11/64	.1719	21/64	.3281	53/64	.8281
52	.0635	17	.173	Q	.332	27/32	.8438
51	.067	16	.177	R	.339	55/64	.8594
50	.070	15	.180	11/32	.3438	7/8	.875
49	.073	14	.182	S	.348	57/64	.8906
48	.076	13	.185	T	.358	29/32	.9062
5/64	.0731	3/16	.1875	23/64	.3594	59/64	.9219
47	.0785	12	.189	U	.368	15/16	.9375
46	.081	11	.191	3/8	.375	61/64	.9531
45	.082	10	.1935	V	.377	31/32	.9688
44	.086	9	.196	W	.386	63/64	.9844

## 4-27. Hand Tap Nomenclature.

- a. Angle of Thread. The Angle included between the flanks of the thread measured in an axial plane.
- b. Back Taper. A slight axial relief on the thread of the tap which makes the pitch diameter of the thread near the shank somewhat smaller than that of the chamfered end.
- c. Basic. The theoretical or nominal standard size from which all variations are made.
- d. Chamfer. The tapering of the threads at the front end of each land of a tap by cutting away and relieving the crest of the first few teeth to distribute the cutting action over several teeth. When the tapering amounts to 7 to 10 threads, the tap is called a "Taper" Tap; 3 to 5 threads, a "Plug" Tap; and 1 to 2 threads, a "Bottoming" Tap.
- e. Chamfer Relief. The gradual decrease in land height from cutting edge to heel on the chamfered portion, to provide clearance for the cutting action as the tap advances
- f. Crest. The top surface joining the two flanks of a thread. The crest of an external thread is at its major diameter, while the crest of an internal thread is at its minor diameter.
- g. Cutting Face. The leading side of the land in the direction of rotation for cutting on which the chip impinges.
- h. Dryseal. A pipe threaded fuel connection for both external and internal application designed for use where the assembled product must withstand high fluid or gas pressures without the use of a sealing compound, or where a sealer is functionally objectionable.
- i. Flutes. The longitudinal channels formed in a tap to create cutting edges on the thread profile and to provide chip spaces and cutting fluid passages.
- j. Height of Thread. The distance between the crest and the base of a thread measured normal to the axis.
- k. Helical Flute. A flute with uniform axial lead and constant helix in a helical path around the axis of a cylindrical tap.
- l. Hook Face. A concave cutting face, usually specified either as Chordal Hook or Tangential Hook.
- m. Chordal Hook Angle. The angle between the chord passing through the root and crest of a thread form at the cutting face, and a radial line through the crest of the cutting edge.
- n. Tangential Hook Angle. The angle between a line tangent to a hook cutting face at the cutting edge and a radial line to the same point
- o. Interrupted Thread. A tap having an odd number of lands, with every other tooth along the thread helix removed.
- p. Lead. The distance a screw thread advances axially in one complete turn. On a single lead screw or tap, the lead and pitch are identical. On a double lead screw or tap, the lead is twice the pitch, etc.
- q. Threads Per Inch. The number of threads in one inch of length.
- r. Pitch. The distance from any point on a screw or tap thread to a corresponding point on the next thread, measured parallel to the axis The pitch equals one divided by the number of threads per inch.
- s. Pitch Diameter. On a straight thread, the diameter of an imaginary coaxial cylinder, the surface of which would pass through the thread profile at such points as to make equal the width of the threads and the width of the spaces cut by the surface of the cylinder. On a Taper thread, the diameter at a given distance from a reference plane perpendicular to the axis of an imaginary co-axial cone, the surface of which would pass through the thread profile at such points as to make equal the width of the threads and the width of the spaces cut by the surface of the cone.

4-27. Hand Tap Nomenclature - Continued

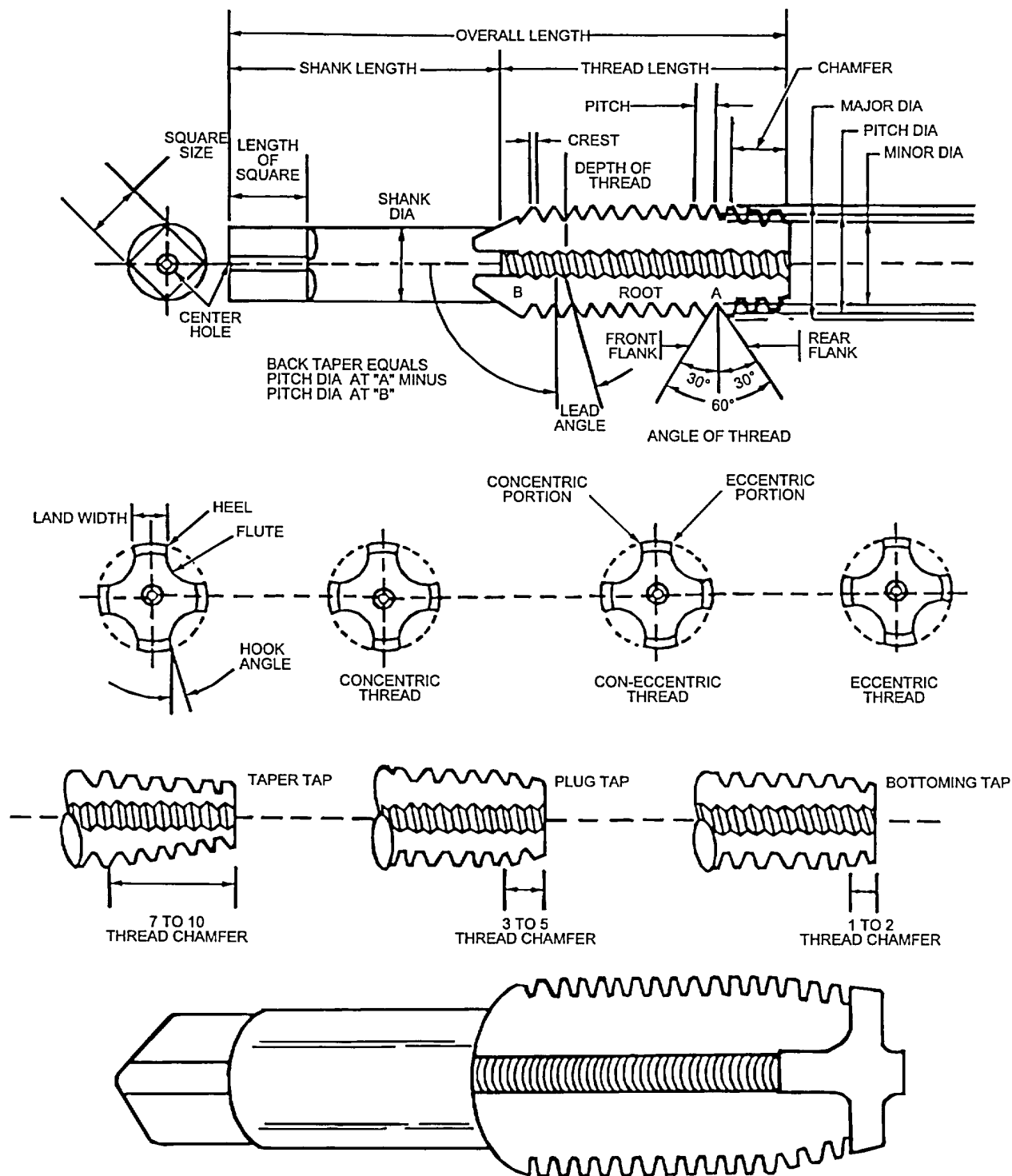

Figure 4-55. Hand Tap Details

4-27. Hand Tap Nomenclature - Continued

t. Rake. Any deviation of a straight cutting face of the tooth from a radial line. Positive Rake means that the crest of the cutting face is angularly advanced ahead of the balance of the face of the tooth. Negative Rake means that the same point is angularly behind the balance of the cutting face of the tooth. Zero Rake means that the cutting face is directly on the center line.

u. Root. The bottom surface joining the flanks of two adjacent threads. The root of an external thread is at its minor diameter, while the root of an internal thread is at its major diameter.

v. Spiral Point (Chip Driver). A supplementary angular fluting cut in the cutting face of the land at the chamfer end. It is slightly longer than the chamfer on the tap and of the opposite hand to that of rotation.

w. Thread Relief. The clearance produced by removal of metal from behind the cutting edge. When the thread angle is relieved from the heel to cutting edge, the tap is said to have "Eccentric" relief. If relieved from heel for only a portion of land width, the tap is said to have "Con-eccentric" relief.

4-28. Thread Limits.

Table 4-10. Thread Limits, Type I, Series A Through C, Cut Thread Taps

Screw Gage Number or Diameter	Threads Per Inch			Major Diameter Limits			Pitch Diameter Limits		
	Series A	Series B	Series C	Basic	Min.	Max.	Basic	Min	Max.
Inches				Inch	Inch	Inch	Inch	Inch	Inch
0.....	.....	80	.....	0.0600	0.0609	0.0624	0.0519	0.0521	0.0531
1.....	64	.....	.....	.0730	.0740	.0755	.0629	.0631	.0641
1.....	.....	72	.....	.0730	.0740	.0755	.0640	.0642	.0652
2.....	56	.....	.....	.0860	.0872	.0887	.0744	.0746	.0756
2.....	.....	64	.....	.0860	.0870	.0885	.0759	.0761	.0771
3.....	48	.....	.....	.0990	.1003	.1018	.0855	.0857	.0867
3.....	.....	56	.....	.0990	.1002	.1017	.0874	.0876	.0886
4.....	.....	.....	32	.1120	.1142	.1162	.0917	.0922	.0937
4.....	.....	.....	36	.1120	.1137	.1157	.0940	.0942	.0957
4.....	40	.....	.....	.1120	.1136	.1156	.0958	.0960	.0975
4.....	.....	48	.....	.1120	.1133	.1153	.0985	.0987	.1002
5.....	40	.....	.....	.1250	.1266	.1286	.1088	.1090	.1105
5.....	.....	44	.....	.1250	.1264	.1284	.1102	.1104	.1119
6.....	32	.....	.....	.1380	.1402	.1422	.1177	.1182	.1197
6.....	.....	.....	36	.1380	.1397	.1417	.1200	.1202	.1217
6.....	.....	40	.....	.1380	.1396	.1416	.1218	.1220	.1235
8.....	32	.....	.....	.1640	.1662	.1682	.1437	.1442	.1457
8.....	.....	36	.....	.1640	.1657	.1677	.1460	.1462	.1477
8.....	.....	.....	40	.1640	.1656	.1676	.1478	.1480	.1495
10.....	24	.....	.....	.1900	.1928	.1948	.1629	.1634	.1649
10.....	.....	.....	30	.1900	.1923	.1943	.1684	.1689	.1704
10.....	.....	32	.....	.1900	.1922	.1942	.1697	.1702	.1717
12.....	24	.....	.....	.2160	.2188	.2208	.1889	.1894	.1909
12.....	.....	28	.....	.2160	.2184	.2204	.1928	.1933	.1948
12.....	.....	.....	32	.2160	.2182	.2202	.1957	.1962	.1977
14.....	.....	.....	20	.2420	.2452	.2477	.2095	.2100	.2120

4-28. Thread Limits - Continued

Table 4-10. Thread Limits, Type I, Series A Through C, Cut Thread Taps - Continued

Screw Gage Number or Diameter	Threads Per Inch			Major Diameter Limits			Pitch Diameter Limits		
	Series A	Series B	Series C	Basic	Min.	Max.	Basic	Min.	Max.
Inches				Inch	Inch	Inch	Inch	Inch	Inch
14.....			24	.2420	.2448	.2473	.2149	.2154	.2174
1/16.....			64	.0625	.0635	.0650	.0524	.0526	.0536
3/32.....			48	.0938	.0951	.0966	.0803	.0805	.0815
1/8.....			40	.1250	.1266	.1286	.1088	.1090	.1105
5/32.....			32	.1563	.1585	.1605	.1360	.1365	.1380
5/32.....			36	.1563	.1580	.1600	.1382	.1384	.1399
3/16.....			24	.1875	.1903	.1923	.1604	.1609	.1624
3/16.....			32	.1875	.1897	.1917	.1672	.1677	.1692
7/32.....			24	.2188	.2216	.2236	.1917	.1922	.1937
7/32.....			32	.2188	.2210	.2230	.1985	.1990	.2005
1/4.....	20			.2500	.2532	.2557	.2175	.2180	.2200
1/4.....			24	.2500	.2528	.2553	.2229	.2234	.2254
1/4.....		28		.2500	.2524	.2549	.2268	.2273	.2288
1/4.....			32	.2500	.2522	.2547	.2297	.2302	.2317
5/16.....	18			.3125	.3160	.3185	.2764	.2769	.2789
5/16.....		24		.3125	.3153	.3178	.2854	.2859	.2874
5/16.....			32	.3125	.3147	.3172	.2922	.2927	.2942
3/8.....	16			.3750	.3789	.3814	.3344	.3349	.3369
3/8.....		24		.3750	.3778	.3803	.3479	.3484	.3499
7/16.....	14			.4375	.4419	.4449	.3911	.3916	.3941
7/16.....		20		.4375	.4407	.4437	.4050	.4055	.4075
1/2.....	13			.5000	.5047	.5077	.4500	.4505	.4530
1/2.....		20		.5000	.5032	.5062	.4675	.4680	.4700
9/16.....	12			.5625	.5675	.5705	.5084	.5089	.5114
9/16.....		18		.5625	.5660	.5690	.5264	.5269	.5289
5/8.....	11			.6250	.6304	.6334	.5660	.5665	.5690
5/8.....			12	.6250	.6300	.6330	.5709	.5714	.5739
5/8.....		18		.6250	.6285	.6315	.5889	.5894	.5914
11/16.....			11	.6875	.6929	.6969	.6285	.6290	.6320
11/16.....			16	.6875	.6914	.6954	.6469	.6474	.6499
3/4.....	10			.7500	.7559	.7599	.6850	.6855	.6885
3/4.....		16		.7500	.7539	.7579	.7094	.7099	.7124
7/8.....	9			.8750	.8820	.8860	.8028	.8038	.8068
7/8.....		14		.8750	.8799	.8839	.8286	.8296	.8321
1.....	8			1.0000	1.0078	1.0118	.9188	.9198	.9228
1.....		12		1.0000	1.0055	1.0095	.9459	.9469	.9499
1.....			14	1.0000	1.0049	1.0089	.9536	.9546	.9571
1-1/8.....	7			1.1250	1.1337	1.1382	1.0322	1.0332	1.0367
1-1/8.....		12		1.1250	1.1305	1.1350	1.0709	1.0719	1.0749
1-1/4.....	7			1.2500	1.2587	1.2632	1.1572	1.1582	1.1617
1-1/4.....		12		1.2500	1.2555	1.2600	1.1959	1.1969	1.1999
1-3/8.....	6			1.3750	1.3850	1.3895	1.2667	1.2677	1.2712
1-3/8.....		12		1.3750	1.3805	1.3850	1.3209	1.3219	1.3249
1-1/2.....	6			1.5000	1.5100	1.5145	1.3917	1.3927	1.3962
1-1/2.....		12		1.5000	1.5055	1.5100	1.4459	1.4469	1.4499
1-3/4.....	5			1.7500	1.7602	1.7657	1.6201	1.6216	1.6256
2.....	4-1/2			2.0000	2.0111	2.0166	1.8557	1.8572	1.8612

4-28. Thread Limits - Continued

Table 4-11. Thread Limits, Type II, Series D Through G

Nominal Size Basic	Pitch				Major Diameter		Pitch Diameter		
	Series D	Series E	Series F	Series G	Min	Max.	Basic Pitch Diameter	Min.	Max.
Mm.	Mm.	Mm.	Mm.	Mm.	Mm.	Mm.	Mm.	Mm.	Mm.
1.5.....	.....	.....	.....	0.35	1.524	1.562	1.273	1.278	1.303
2.....	0.45	.....	.....	.....	2.029	2.068	1.708	1.712	1.737
2.5.....	.45	.....	.....	.....	2.530	2.568	2.208	2.212	2.238
3.....	.60	.....	.....	.....	3.040	3.091	2.610	2.616	2.654
3.5.....	.60	.....	.....	.....	3.541	3.592	3.110	3.117	3.155
4.....	.75	.....	.....	.....	4.056	4.107	3.513	3.526	3.564
4.5.....	.75	.....	.....	.....	4.557	4.608	4.013	4.026	4.064
5.....	.90	.....	.....	.....	5.060	5.110	4.415	4.427	4.465
5.5.....	.90	.....	.....	.....	5.560	5.611	4.915	4.928	4.966
6.....	1.00	.....	.....	.....	6.066	6.116	5.350	5.364	5.403
7.....	1.00	.....	.....	.....	7.066	7.130	6.350	6.363	6.414
8.....	.....	1.25	.....	.....	8.082	8.146	7.188	7.201	7.252
9.....	.....	1.25	.....	.....	9.081	9.144	8.188	8.202	8.252
10.....	.....	.....	1.00	.....	10.071	10.147	9.350	9.362	9.413
10.....	1.50	.....	.....	.....	10.099	10.175	9.026	9.037	9.101
12.....	.....	1.75	.....	.....	12.111	12.187	10.863	10.876	10.940
14.....	.....	.....	1.25	.....	14.082	14.158	13.188	13.200	13.241
14.....	2.00	.....	.....	.....	14.120	14.196	12.701	12.713	12.776
16.....	2.00	.....	.....	.....	16.119	16.220	14.701	14.714	14.790
18.....	.....	.....	1.50	.....	18.100	18.202	17.026	17.038	17.102
18.....	2.50	.....	.....	.....	18.151	18.252	16.376	16.388	16.464
20.....	2.50	.....	.....	.....	20.163	20.264	18.376	18.402	18.478
22.....	2.50	.....	.....	.....	22.162	22.263	20.376	20.401	20.478
24.....	3.00	.....	.....	.....	24.184	24.285	20.051	22.078	22.154

## CHAPTER 5

## MEASUREMENT AND MECHANICAL DATA

## Section I. MEASUREMENT DATA

## 5-1. U.S. and Metric Measurement Data.

a. U.S. Measurement System. In the U.S. System, fundamental units are the inch, foot, second, and pound. The U.S. System has its origins in the British System, but they are not identical.

b. Metric Measurement System. In the Metric System the fundamental units are the meter and the kilogram. The Metric system is the most widely used system and the system used almost exclusively for scientific work.

## 5-2. Metric Prefixes

The basic prefixes used in the Metric System are listed in table 5-1.

Table 5-1. Metric Prefixes

Whole numbers	Multiple	Prefix	Abbreviation
1,000,000,000,000	$10^{12}$	tera	T
1,000,000,000	$10^9$	giga	G
1,000,000	$10^6$	mega	M
10,000	$10^4$	myria	My
1,000	$10^3$	kilo	K
100	$10^2$	hecto	H
1	10	deka	D
.1	$10^{-1}$	deci	d
.01	$10^{-2}$	centi	c
.001	$10^{-3}$	milli	m
.000001	$10^{-6}$	micro	u
.000000001	$10^{-9}$	nano	n
.0000000000001	$10^{-12}$	pico	p
.0000000000000001	$10^{-15}$	femto	f
.000000000000000001	$10^{-18}$	atto	a

**5-3. Measurement Units.**

a. U.S. System Weights and Measures. Some of the more common U.S. System units of weights and measures are listed in table 5-2.

*Table 5-2. Weights and Measures - U.S. System*

<b>Unit</b>	<b>Equivalent</b>
Length	
inch	0.083 foot
foot	12 inches
yard	3 feet
mile (statute)	5280 feet
mile (nautical)	1.1508 statute mile
Area	
square inch	0.007 square foot
square foot	144 square inches
acre	43,560 square feet
square mile	640 acres
Volume	
cubic inch	0.00058 cubic foot
cubic foot	1728 cubic inches
cubic yard	27 cubic feet
Capacity	
fluid ounce	1.804 cubic inches
pint	16 fluid ounces, 28.875 cubic inches
quart	2 pints, 57.75 cubic inches
gallon	4 quarts, 231 cubic inches
barrel	31-1/2 gallons
Weight	
grain	0.002285 ounce
dram	0.0625 ounce
ounce	437.5 grains
pound	16 ounces
ton	2000 pounds

b. Metric System Weights and Measures. Some of the more common Metric System units of weights and measures are listed in table 5-3.

*Table 5-3. Weights and Measures - Metric System*

<b>Unit</b>	<b>Equivalent</b>
Length	
millimeter	0.001 meter
centimeter	0.01 meter
decimeter	0.1 meter
meter	1000 millimeters
kilometer	1000 meters



5-3. Measurement Units - Continued

Table 5-3. Weights and Measures - Metric System - Continued

Unit	Equivalent
Area	
square millimeter	0.01 square centimeter
square centimeter	100 square millimeters
square decimeter	10,000 square centimeters
square kilometer	10,000,000,000 square centimeters
Volume	
cubic millimeter	0.001 cubic centimeter
cubic centimeter	1,000 cubic millimeters
cubic meter	1,000,000,000 cubic millimeters
Capacity	
milliliter	0.001 liter
centiliter	10 milliliters
liter	1000 milliliters
kiloliter	1000 liters
Weight	
milligram	0.001 gram
centigram	10 milligrams
kilogram	1000 grams
metric ton	1000 kilograms

4. c. U.S. to Metric Measurement System Conversion. Metric equivalents for the U.S. System are listed in table 5-

Table 5-4. U.S. System to Metric System Conversion

U.S. system unit	Metric equivalent
Length	
inch	2.54 centimeters
foot	0.3048 meter
yard	0.9144 meter
mile (statute)	1.609 kilometers
Area	
square inch	6.4516 square centimeters
square foot	929.030 square centimeters
acre	4047 square meters
square mile	2.590 square kilometers
Volume	
cubic inch	16.387 cubic centimeters
cubic foot	0.028 cubic meter
cubic yard	0.765 cubic meter
Capacity	
ounce (fluid)	29.573 milliliters
pint	0.473 liter
quart	0.946 liter
gallon	3.785 liter

**5-3. Measurement Units - Continued**

*Table 5-4. U.S. System to Metric System Conversion - Continued*

U.S. system unit	Metric equivalent
Weight	
grain	64.79891 milligrams
dram	1.772 grams
ounce	28.350 grams
pound	453.59237 grams
ton (short)	0.907 metric ton

**5-4. Conversion Factors.**

Table 5-5 lists the multiplying factors needed to convert from one unit of measure to another. Locate the units of measure to be converted in the first or second column. Use the third column to convert units in the first column to units in the second column. Use the fourth column to convert units in the second column to units in the first column.

*Table 5-5. Conversion Factors*

To convert	Into	Multiply by	Conversely, multiply by
Acres	Square feet	$4.356 \times 10^4$	$2.296 \times 10^{-5}$
Acres	Square meters	4047	$2.471 \times 10^{-4}$
Acres	Square miles	$1.5625 \times 10^{-3}$	640
Amperes	Microamperes	$10^6$	$10^{-6}$
Amperes	Picoamperes	$10^{12}$	$10^{-12}$
Amperes	Milliamperes	$10^3$	$10^{-3}$
Amperes-hours	Coulombs	3600	$2.778 \times 10^{-4}$
Ampere-turns	Gilberts	1.257	0.7958
Ampere-turns per cm.	Ampere-turns per in.	2.54	0.3937
Angstrom units	Inches	$3.937 \times 10^{-9}$	$2.54 \times 10^8$

## 5-4. Conversion Factors - Continued

Table 5-5. Conversion Factors - Continued

To convert	Into	Multiply by	Conversely, multiply by
Angstrom units	Meters	$10^{-10}$	$10^{10}$
Atmospheres	Feet of water	33.90	0.02950
Atmospheres	Pounds per sq. in.	14.70	0.06804
Bars	Atmospheres	.9870	1.0133
Bars	Dynes per sq. cm.	$10^6$	$10^{-6}$
Bars	Pounds per sq. in.	14.504	$6.8947 \times 10^{-2}$
Btu	Ergs	$1.0548 \times 10^{10}$	$9.486 \times 10^{-11}$
Btu	Foot-pounds	778.3	$1.285 \times 10^{-3}$
Btu	Joules	1054.8	$9.480 \times 10^{-4}$
Btu	Kilogram-calories	0.252	3.969
Btu per hour	Horsepower	$3.929 \times 10^{-4}$	2545
Bushels	Cubic feet	1.2445	0.8036
Calories, gram	Joules	4.185	0.2389
Centigrade	Celsius	1	1
Centigrade	Fahrenheit	$(^{\circ}\text{C} \times 9/5) + 32 = ^{\circ}\text{F}$	$(^{\circ}\text{F} - 32) \times 5/9 = ^{\circ}\text{C}$
Centigrade	Kelvin	$(^{\circ}\text{C} + 273.1 = ^{\circ}\text{K}$	$^{\circ}\text{K} - 273.1 = ^{\circ}\text{C}$
Chains (surveyor's)	Feet	66	$1.515 \times 10^{-2}$
Circular mils	Square centimeters	$5.067 \times 10^{-6}$	$1.973 \times 10^5$
Circular mils	Square mils	0.7854	1.273
Cubic feet	Gallons (liq. U.S.)	7.481	0.1337
Cubic feet	Liters	28.32	$3.531 \times 10^{-2}$
Cubic inches	Cubic centimeters	16.39	$6.102 \times 10^{-2}$

## 5-4. Conversion Factors - Continued

Table 5-5. Conversion Factors - Continued

To convert	Into	Multiply by	Conversely, multiply by
Cubic inches	Cubic feet	$5.787 \times 10^{-4}$	1728
Cubic inches	Cubic meters	$1.639 \times 10^{-5}$	$6.102 \times 10^4$
Cubic inches	Gallons (liq. U.S.)	$4.329 \times 10^{-3}$	231
Cubic meters	Cubic feet	35.31	$2.832 \times 10^{-2}$
Cubic meters	Cubic yards	1.308	0.7646
Cycles per second	Hertz	1	1
Degrees (angle)	Mils	17.78	0.0562
Degrees (angle)	Radians	$1.745 \times 10^{-2}$	57.3
Dynes	Pounds	$2.248 \times 10^{-6}$	$4.448 \times 10^5$
Ergs	Foot-pounds	$7.376 \times 10^{-8}$	$1.356 \times 10^7$
Fahrenheit	Rankine	$^{\circ}\text{F} + 459.58 = ^{\circ}\text{R}$	$^{\circ}\text{R} - 459.58 = ^{\circ}\text{F}$
Faradays	Ampere-hours	26.8	$3.731 \times 10^{-2}$
Farads	Microfarads	$10^6$	$10^{-6}$
Farads	Picofarads	$10^{12}$	$10^{-12}$
Farads	Millifarads	$10^3$	$10^{-3}$
Fathoms	Feet	6	0.16667
Feet	Centimeters	30.48	$3.281 \times 10^{-2}$
Feet	Meters	0.3048	3.281
Feet	Mils	$1.2 \times 10^4$	$8.333 \times 10^{-5}$
Foot-pounds	Gram-centimeters	$1.383 \times 10^4$	$1.235 \times 10^{-5}$
Foot-pounds	Horsepower-hours	$5.05 \times 10^{-7}$	$1.98 \times 10^6$
Foot-pounds	Kilogram-meters	0.1383	7.233
Foot-pounds	Kilowatt-hours	$3.766 \times 10^{-7}$	$2.655 \times 10^6$

## 5-4. Conversion Factors - Continued

Table 5-5. Conversion Factors - Continued

To convert	Into	Multiply by	Conversely, multiply by
Foot-pounds	Ounce-inches	192	$5.208 \times 10^{-3}$
Gallons (liq. U.S.)	Cubic meters	$3.785 \times 10^{-3}$	264.2
Gallons (liq. U.S.)	Gallons (liq. BR. Imp.)	0.8327	1.201
Gausses	Lines per sq. cm.	1.0	1.0
Gausses	Lines per sq. in.	6.452	0.155
Gausses	Webers per sq. in.	$6.452 \times 10^{-8}$	$155 \times 10^7$
Grams	Dynes	980.7	$1.02 \times 10^{-3}$
Grams	Grains	15.43	$6.481 \times 10^{-2}$
Grams	Ounces (avdp.)	$3.527 \times 10^{-2}$	28.35
Grams	Poundals	$7.093 \times 10^{-2}$	14.1
Grams per cm.	Pounds per in.	$5.6 \times 10^2 10^{-3}$	178.6
Grams per cu. cm.	Pounds per cu. in.	$3.613 \times 10^{-2}$	27.68
Henries	Microhenries	$10^6$	$10^{-6}$
Henries	Millihenries	$10^3$	$10^{-3}$
Hertz	Kilohertz	$10^{-3}$	$10^3$
Hertz	Megahertz	$10^{-6}$	$10^6$
Horsepower	Btu per minute	42.44	0.02356
Horsepower	Foot-lbs. per minute	$3.3 \times 10^4$	$3.03 \times 10^{-5}$
Horsepower	Foot-lbs. per second	550	$1.182 \times 10^{-3}$
Horsepower	Horsepower (metric)	1.014	0.9863
Horsepower	Kilowatts	0.746	1.341
Inches	Centimeters	2.54	0.3937
Inches	Feet	$8.333 \times 10^{-2}$	12

## 5-4. Conversion Factors - Continued

Table 5-5. Conversion Factors - Continued

To convert	Into	Multiply by	Conversely, multiply by
Inches	Meters	$2.54 \times 10^{-2}$	39.37
Inches	Miles	$1.578 \times 10^{-5}$	$6.336 \times 10^4$
Inches	Mils	$10^3$	$10^{-3}$
Inches	Yards	$2.778 \times 10^{-2}$	36
Joules	Foot-pounds	0.7376	1.356
Joules	Ergs	$10^7$	$10^{-7}$
Joules	Watt-hours	$2.778 \times 10^{-4}$	3600
Kilograms	Tons (metric)	$10^3$	$10^{-3}$
Kilograms	Tons (long)	$9.842 \times 10^{-4}$	1016
Kilograms	Tons (short)	$1.102 \times 10^{-3}$	907.2
Kilograms	Pounds (avdp.)	2.205	0.4536
Kilograms per meter	Pounds per sq. foot	0.2048	4.882
Kilometers	Feet	3281	$3.408 \times 10^{-4}$
Kilometers	Inches	$3.937 \times 10^4$	$54 \times 10^{-5}$
Kilometers	Light years	$1.0567 \times 10^{-13}$	$9.4637 \times 10^{12}$
Kilometers per hr.	Feet per minute	54.68	$1.829 \times 10^{-2}$
Kilometers per hr.	Knots	0.5396	1.8532
Kilowatt-hours	Btu	3413	$2.93 \times 10^{-4}$
Kilowatt-hours	Foot-pounds	$2.655 \times 10^6$	$3.766 \times 10^7$
Kilowatt-hours	Joules	$3.6 \times 10^6$	$2.778 \times 10^{-7}$
Kilowatt-hours	Horsepower-hours	1.341	0.7457
Kilowatt-hours	Pounds water evaporated from and at 212°F	3.53	0.284

## 5-4. Conversion Factors - Continued

Table 5-5. Conversion Factors - Continued

To convert	Into	Multiply by	Conversely, multiply by
Kilowatt-hours	Watt-hours	$10^3$	$10^{-3}$
Knots	Feet per second	1.688	0.5925
Knots	Meters per minute	30.87	0.0324
Knots	Miles per hour	1.1508	0.869
Lamberts	Candles per sq. cm.	0.3183	3.142
Lamberts	Candles per sq. in.	2.054	0.4869
Leagues	Miles	3	0.33
Links (surveyor's)	Chains	0.01	100
Links (surveyor's)	Inches	7.92	0.1263
Liters	Bushels (dry U.S.)	$2.838 \times 10^{-2}$	35.24
Liters	Cubic centimeters	$10^3$	$10^{-3}$
Liters	Cubic meters	$10^{-3}$	$10^3$
Liters	Cubic inches	61.02	$1.639 \times 10^{-2}$
Liters	Gallons (liq. U.S.)	0.2642	3.785
Liters	Pints (liq. U.S.)	2.113	0.4732
$\text{Log}_e N$ ( $L_n N$ )	$\text{Log}_{10} N$	0.4343	2.303
Lumens per sq. ft.	Foot-candles	1	1
Lux	Foot-candles	0.0929	10.764
Maxwells	Kilolines	$10^{-3}$	$10^3$
Maxwells	Megalines	$10^{-6}$	$10^6$
Maxwells	Webers	$10^{-8}$	$10^8$
Meters	Centimeters	$10^2$	$10^{-2}$
Meters	Feet	3.28	$30.48 \times 10^{-2}$

## 5-4. Conversion Factors - Continued

Table 5-5. Conversion Factors - Continued

To convert	Into	Multiply by	Conversely, multiply by
Meters	Inches	39.37	$2.54 \times 10^{-2}$
Meters	Kilometers	$10^{-3}$	$10^3$
Meters	Miles (statute)	$6.214 \times 10^{-4}$	1609.35
Meters	Yards	1.094	0.9144
Meters per minute	Feet per minute	3.281	0.3048
Meters per minute	Kilometers per hour	0.06	16.67
Mhos	Micromhos	$10^6$	$10^{-6}$
Mhos	Millimhos	$10^3$	$10^{-3}$
Microfarads	Picofarads	$10^6$	$10^{-6}$
Miles (nautical)	Feet	6076.1	$1.646 \times 10^{-4}$
Miles (nautical)	Meters	1852	$5.4 \times 10^{-4}$
Miles (statute)	Feet	5280	$1.894 \times 10^{-4}$
Miles (statute)	Kilometers	1.609	0.6214
Miles (statute)	Light years	$1.691 \times 10^{-13}$	$5.88 \times 10^{12}$
Miles (statute)	Miles (nautical)	0.869	1.1508
Miles (statute)	Yards	1760	$5.6818 \times 10^{-4}$
Miles per hour	Feet per minute	88	$1.136 \times 10^{-2}$
Miles per hour	Feet per second	1.467	0.6818
Miles per hour	Kilometers per hour	1.609	0.6214
Miles per hour	Knots	0.8684	1.1508
Milliamperes	Microamperes	$10^3$	$10^{-3}$
Millihenries	Microhenries	$10^3$	$10^{-3}$
Millimeters	Centimeters	0.1	10



## 5-4. Conversion Factors - Continued

Table 5-5. Conversion Factors - Continued

To convert	Into	Multiply by	Conversely, multiply by
Millimeters	Inches	$3.937 \times 10^{-2}$	25.4
Millimeters	Microns	$10^3$	$10^{-3}$
Millivolts	Microvolts	$10^3$	$10^{-3}$
Mils (angle)	Minutes	3.375	0.2963
Minutes (angle)	Degrees	$1.666 \times 10^{-2}$	60
Nepers	Decibels	8.686	0.1151
Newtons	Dynes	$10^5$	$10^{-5}$
Newtons	Pounds (avdp.)	0.2248	4.448
Ohms	Milliohms	$10^3$	$10^{-3}$
Ohms	Micro-ohms	$10^6$	$10^{-6}$
Ohms	Pico-ohms	$10^{12}$	$10^{-12}$
Ohms	Megohms	$10^{-6}$	$10^6$
Ohms	Ohms (International)	0.99948	1.00052
Ohms per foot	Ohms per meter	0.3048	3.281
Ounces (fluid)	Quarts	$3.125 \times 10^{-2}$	32
Ounces (avdp.)	Pounds	$6.25 \times 10^{-2}$	16
Picofarad	Micromicrofarad	1	1
Pints	Quarts (liq. U.S.)	0.50	2
Pounds	Grams	453.6	$2.205 \times 10^{-3}$
Pounds (force)	Newtons	4.4482	0.2288
Pounds carbon oxidized	Btu	14,544	$6.88 \times 10^{-5}$
Pounds carbon oxidized	Horsepower-hours	5.705	0.175

## 5-4. Conversion Factors - Continued

Table 5-5. Conversion Factors - Continued

To convert	Into	Multiply by	Conversely, multiply by
Pounds carbon	Kilowatt-hours	4.254	0.235
Pounds of water	Cubic feet	$1.603 \times 10^{-2}$	62.38
Pounds of water	Gallons	0.1198	8.347
Pounds per sq. in.	Dynes per sq. cm.	$6.8946 \times 10^4$	$1.450 \times 10^{-5}$
Pounds per sq. in.	Head (in feet)	2.31	0.433
Poundals	Dynes	$1.383 \times 10^4$	$7.233 \times 10^{-5}$
Poundals	Pounds (avdp.)	$3.108 \times 10^{-2}$	32.17
Quadrants	Degrees	90	$11.111 \times 10^{-2}$
Quadrants	Radians	1.5708	0.637
Radians	Mils	1018.59	$9.8175 \times 10^{-4}$
Radians	Minutes	$3.438 \times 10^3$	$2.909 \times 10^{-4}$
Radians	Seconds	$2.06265 \times 10^5$	$4.848 \times 10^{-6}$
Rods	Feet	16.5	$6.061 \times 10^{-2}$
Rods	Miles	$3.125 \times 10^{-3}$	320
Rods	Yards	5.5	0.1818
Rpm	Degrees per second	6.0	0.1667
Rpm	Radians per second	0.1047	9.549
Rpm	Rps	$1.667 \times 10^{-2}$	60
Square feet	Acres	$2.296 \times 10^{-5}$	43,560
Square feet	Square centimeters	929.034	$1.076 \times 10^{-3}$
Square feet	Square inches	144	$6.944 \times 10^{-3}$
Square feet	Square meters	$9.29 \times 10^{-2}$	10.764

## 5-4. Conversion Factors - Continued

Table 5-5. Conversion Factors - Continued

To convert	Into	Multiply by	Conversely, multiply by
Square feet	Square miles	$3.587 \times 10^{-8}$	$27.88 \times 10^6$
Square feet	Square yards	$11.11 \times 10^{-2}$	9
Square inches	Circular mils	$1.273 \times 10^6$	$7.854 \times 10^{-7}$
Square inches	Square centimeters	6.452	0.155
Square inches	Square mils	$10^6$	$10^{-6}$
Square inches	Square millimeters	645.2	$1.55 \times 10^{-3}$
Square kilometers	Square miles	0.3861	2.59
Square meters	Square yards	1.196	0.8361
Square miles	Acres	640	$1.562 \times 10^{-3}$
Square miles	Square yards	$3.098 \times 10^6$	$3.228 \times 10^{-7}$
Square millimeters	Circular mils	1973	$5.067 \times 10^{-4}$
Square millimeters	Square centimeters	0.01	100
Square mils	Circular mils	1.273	0.7854
Tons (long)	Pounds (avdp.)	2240	$4.464 \times 10^{-4}$
Tons (short)	Pounds	2,000	$5 \times 10^4$
Tons (metric)	Pounds	2204.63	$4.536 \times 10^4$
Varas	Feet	2.7777	0.36
Volts	Kilovolts	$10^{-3}$	$10^3$
Volts	Microvolts	$10^6$	$10^{-6}$
Volts	Millivolts	10	$10^{-3}$
Watts	Btu per hour	3.413	0.293
Watts	Btu per minute	$5.689 \times 10^{-2}$	17.58
Watts	Ergs per second	$10^7$	$10^{-7}$

## 5-4. Conversion Factors - Continued

Table 5-5. Conversion Factors - Continued

To convert	Into	Multiply by	Conversely, multiply by
Watts	Foot-lbs per minute	44.26	$2.26 \times 10^{-2}$
Watts	Foot-lbs per second	0.7378	1.356
Watts	Horsepower	$1.341 \times 10^{-3}$	746
Watts per minute	Kilogram-calories	$1.433 \times 10^{-2}$	69.77
Watts	Kilowatts	$10^{-3}$	$10^3$
Watts	Microwatts	$10^6$	$10^{-6}$
Watts	Milliwatts	$10^3$	$10^{-3}$
Watt-seconds	Joules	1	1
Webers	Maxwells	$10^8$	$10^{-8}$
Webers per sq. meter	Gausses	$10^4$	$10^{-4}$
Yards	Feet	3	0.3333
Yards	Varas	1.08	0.9259

## Section II. TEMPERATURE DATA

## 5-5. Temperature Scales.

a. Celsius. Celsius or centigrade is a temperature scale that registers the freezing point of water as  $0^{\circ}\text{C}$  and the boiling point as  $100^{\circ}\text{C}$  under normal atmospheric pressure. Celsius is the official designation for this scale, but centigrade is commonly used.

b. Fahrenheit. Fahrenheit is a temperature scale that registers the freezing point commonly used. of water as  $32^{\circ}\text{F}$  and the boiling point as  $212^{\circ}\text{F}$  under normal atmospheric pressure.

c. Kelvin. Kelvin is a temperature scale on which the degree intervals are equal to those of the Celsius scale. On the Kelvin temperature scale the freezing point of water is  $273.16^{\circ}\text{K}$  and the boiling point is  $373.16^{\circ}\text{K}$ .

**5-5. Temperature Scales - Continued**

d. Rankine. Rankine is a temperature scale on which the degree intervals are equal to those of the Fahrenheit scale. On the Rankine temperature scale the freezing point of water is 491.69°R and the boiling point is 671.69°R.

**5-6. Temperature Conversion.**

a. Familiar temperatures and their equivalent values are listed in table 5-6.

*Table 5-6. Temperature Conversion*

Familiar temperature	Centigrade or Celsius	Fahrenheit	Kelvin	Rankine
	°C	°F	°K	°R
Boiling point of water	100	212	373.16	671.7
	95	203	368.16	662.7
	90	194	363.16	653.7
	85	185	358.16	644.7
	78.9	174	352.06	633.7
Boiling point of alcohol	75	167	348.16	626.7
	70	158	343.16	617.7
	65	149	338.16	608.7
	60	140	333.16	599.7
	55	131	328.16	590.7
Melting point of tallow	52.8	127	325.96	586.7
	50	122	323.16	581.7
	45	113	318.16	572.7
	42.2	108	315.36	567.7
	40	104	313.16	563.7
Body temperature	36.7	98	309.86	557.7
	35	95	308.16	554.7
	32.2	90	305.36	549.7
	30	86	303.16	545.7
	26.7	80	299.86	539.7
	25	77	298.16	539.7
	20	68	293.16	527.7
	15.5	60	288.66	519.7
	12.8	55	285.96	514.7
	10	50	283.16	509.7
Freezing point of water	7.2	45	280.36	504.7
	5	41	278.16	500.7
	1.7	35	274.86	494.7
	0	32	273.16	491.7
	-1.1	30	272.06	489.7
	-5	23	268.16	482.7

## 5-6. Temperature Conversion - Continued

Table 5-6. Temperature Conversion - Continued

Familiar temperature	Centigrade or Celsius	Fahrenheit	Kelvin	Rankine
	°C	°F	°K	°R
	-6.7	20	266.46	479.7
	-10	14	263.16	473.7
	-12.2	10	260.96	469.7
	-15	5	258.16	464.7
	-17.8	0	255.36	459.7
	-20	-4	253.16	455.7
	-25	-13	248.16	444.7
	-30	-22	243.16	437.7
	-35	-31	238.16	428.7
	-40	-40	233.16	419.7

- b. Formulas for converting from one temperature scale to another are listed in table 5-7.

Table 5-7. Formulas for Temperature Conversion

Temperature scales	Formulas
Celsius to Fahrenheit	$^{\circ}\text{F} = 9/5^{\circ}\text{C} + 32^{\circ}$
Celsius to Kelvin	$^{\circ}\text{K} = ^{\circ}\text{C} + 273.1^{\circ}$
Fahrenheit to Celsius	$^{\circ}\text{C} = 5/9 (^{\circ}\text{F} - 32)$
Fahrenheit to Rankine	$^{\circ}\text{R} = ^{\circ}\text{F} + 459.58^{\circ}$

## Section III. ANGULAR MEASUREMENT DATA

## 5-7. Degree System.

a. The degree system is a means of measuring and designating angles of arcs. The degree is 1/360 of a circle or the value of the angle formed by dividing a right angle into 90 equal parts. Each degree is divided into 60 parts called minutes and each minute is further divided into 60 parts called seconds

b. In the use of fire control equipment, either degrees or mils may be used to designate angles of elevation and azimuth. One degree equals 17.78 mils. One mil equals 0.056 degrees or 3 minutes 22.5 seconds. Refer to the conversion chart in figure 5-1, for the approximate relative values of given angles of elevation and azimuth in degrees and mils.

**5-8. Mil System.**

a. The artillery mil system is a means of angular measurement that lends itself to simple mental arithmetic. It provides accuracy within the limits demanded by the military forces with distinct advantages of simplicity and convenience not afforded by any other method of angular measurement. It is based on an arbitrary unit of measurement known as the mil. The mil is exactly 1/6400 of a complete circle

b. The mil is very nearly the angle between two lines which will enclose a distance of 1 meter at a range of 1,000 meters. Exact computation of the distance enclosed at 1,000 meters by 1 mil gives the result of 0.982 meters. Therefore in assuming that 1 mil encloses 1 meter at 1,000 meters, an error of 0.018 meter or 1.8 cm is introduced. This error is negligible for all practical purposes in the use of fire control instruments

c. A circle of 1,000 meters radius would have a circumference of 6,283 meters. A 1 meter portion of the circumference would be the 1/6283 fractional part of a circle. By choosing the mil as the 1/6400 fractional part of a circle, sufficient accuracy is retained for all practical purposes while the number can be handled easily by mental arithmetic.

d. The mil provides an extremely small unit of angular measurement that is easily adaptable to the small angles encountered by the artillery man. For example, if an object has an angular width or height of 1 mil, it is 1 meter wide or high at 1,000 meters; 2 meters wide or high at 2,000 meters; and so on. In angular height, a man is approximately 2 mils tall at 1,000 meters or 1 mil tall at 2,000 meters

**NOTE**

**The Navy mil and the French infantry mil are exactly 1 meter at a range of 1,000 meters. There are 6283.1853 Navy or French infantry mils in a complete circle.**

e. For quick approximate conversion from artillery mils to degrees, or vice versa, refer to figure 5-1. On this chart locate the number of degrees or mils to be converted. Directly across the black line of arc is its equivalent

f. A more exact conversion from artillery mils to degrees, minutes, and seconds is listed in table 5-8.

Example:

Convert 2,569 mils to degrees

2,000 mils =	112°	30'	0"
500 mils =	28°	7'	30"
60 mils =	3°	22'	30"
9 mils =	<u>0</u>	<u>30'</u>	<u>22.5"</u>
	143°	89'	82.5"
2,569 mils =	144°	30'	22.5"

5-8. Mil system - Continued

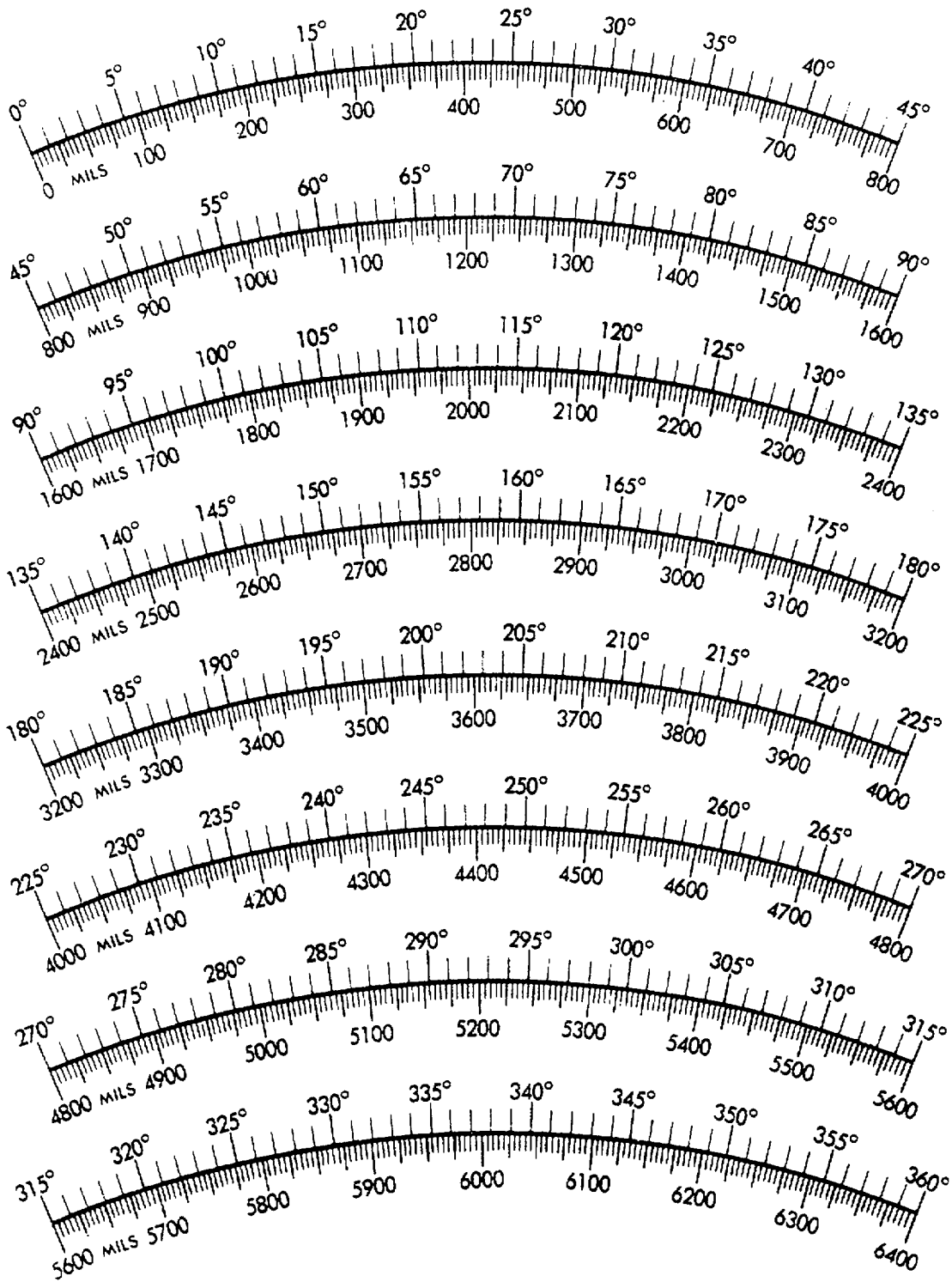

Figure 5-1. Artillery mil to Degree conversion Chart



5-8. Mil system - Continued

Table 5-8. Artillery Mils to Degrees

Artillery mils	Degrees	Minutes	Seconds
1	0	3	22.5
2	0	6	45
3	0	10	7.5
4	0	13	30
5	0	16	52.5
6	0	20	15
7	0	23	37.5
8	0	27	0
9	0	30	22.5
10	0	33	45
20	1	7	30
30	1	41	15
40	2	15	0
50	2	48	45
60	3	22	30
70	3	56	15
80	4	30	0
90	5	3	45
100	5	37	30
200	11	15	0
300	16	52	30
400	22	30	0
500	28	7	30
600	33	45	0
700	39	22	30
800	45	0	0
900	50	37	30
1,000	56	15	0
2,000	112	30	0
3,000	168	45	0
4,000	225	0	0
5,000	281	15	0
6,000	337	30	0
6,400	360	0	0

g. A more exact conversion from degrees to artillery mils is listed in table 5-9.

Example:

Convert 78 degrees 43 minutes to mils.

$$\begin{array}{r}
 70^\circ \quad 0' = 1,244.44 \\
 8^\circ \quad 0' = \quad 142.22 \\
 0^\circ \quad 40' = \quad \quad 11.85 \\
 0^\circ \quad 3' = \quad \quad \quad .89 \\
 \hline
 78^\circ \quad 43' = 1,399.40 \text{ mils}
 \end{array}$$

5-8. Mil System - Continued

Table 5-9. Degrees to Artillery Mils

Degrees	Minutes	Artillery mils
0	1	0.30
0	2	0.59
0	3	0.89
0	4	1.19
0	5	1.48
0	6	1.78
0	7	2.07
0	8	2.37
0	9	2.76
0	10	2.96
0	20	5.93
0	30	8.89
0	40	11.85
0	50	14.82
1	0	17.78
2	0	35.56
3	0	53.33
4	0	71.11
5	0	88.89
6	0	106.67
7	0	124.44
8	0	142.22
9	0	160.00
10	0	177.78
20	0	355.56
30	0	533.33
40	0	711.11
50	0	888.89
60	0	1,066.67
70	0	1,244.44
80	0	1,422.22
90	0	1,600.00
100	0	1,777.78
200	0	3,555.56
300	0	5,333.33
360	0	6,400.00

**5-8. Mil System - Continued**

h. The comparison of 30 minutes of arc to an angular displacement in mils is often necessary when checking the optical alinement of instrument reticles against a collimator reticle.

Example (fig. 5-2):

Thirty minutes of arc is equivalent to the angle, or amount of deviation between the horizontal line of the instrument reticle and the horizontal line of the projector reticle when one end of the instrument reticle line is superimposed on the projector reticle line and the other end of the instrument reticle line is  $\pm 0.5$  mil from the line when measured over a distance of 58 mils along the projector collimator reticle line.

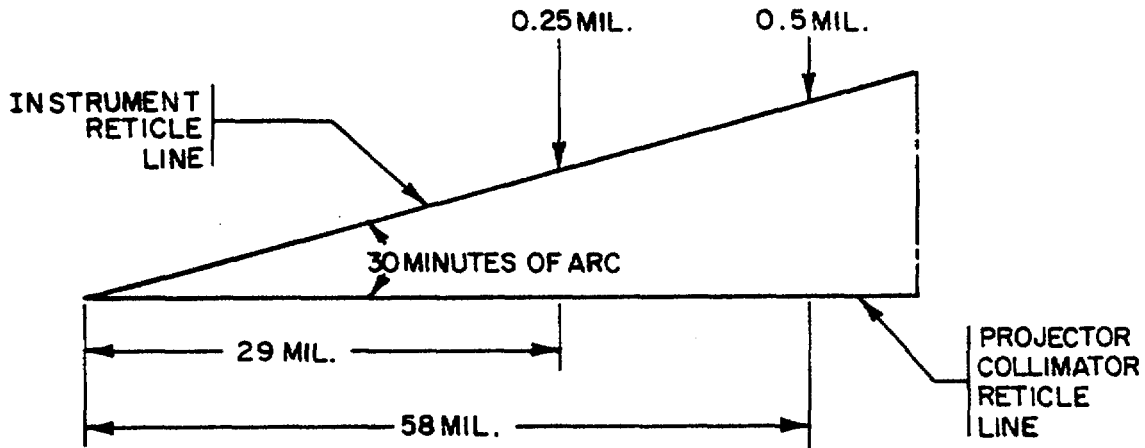

Figure 5-2. Angular Displacement

Thirty minutes of arc, at a distance of 29 mil, will produce a linear displacement of 0.25 mil between the two reticle lines.

Thirty minutes of arc, at a distance of 58 mil, will produce a linear displacement of 0.5 mil between the two reticle lines.

**Section IV. MECHANICAL DATA**

**5-9. Screw Thread.**

a. Several screw thread forms exist, but the most commonly used are those having symmetrical sides at equal angles with a vertical center line through the thread apex, as shown in figure 5-3.

b. The appropriate tap drill sizes for various screw sizes are listed in table 5-10 and table 5-11. The first column in each table is the thread size. The fifth column is the drill tap size. The remaining columns contain general screw data.

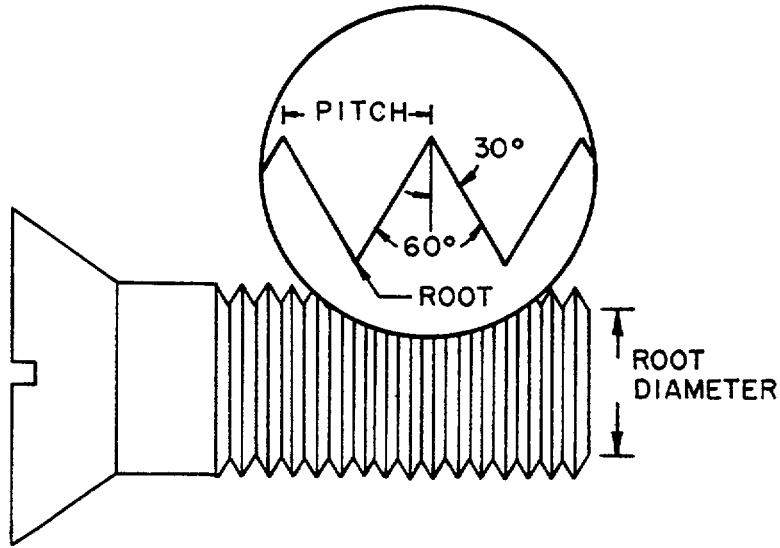

Figure 5-3. Typical Screw Thread Form

Table 5-10. Basic Coarse Thread Dimensions and Tap Drill Sizes - American Machine Screw

Nominal size	Outside diameter (in.)	Pitch diameter (in.)	Root diameter (in.)	Commercial tap drill to produce approx 75 percent full thread	Decimal equivalent of tap drill
Inch Threads per inch					
0-80	0.0600	0.0519	0.0438	3/64	0.0469
1-56	.0730	.0614	.0498	54	.0550
64	.0730	.0629	.0527	53	.0595
72	.0730	.0640	.0550	53	.0595
2-56	.0860	.0744	.0628	50	.0700
64	.0860	.0759	.0657	50	.0700
3-48	.0990	.0855	.0719	47	.0785
56	.0990	.0874	.0758	45	.0820
4-32	.1120	.0917	.0714	45	.0820
36	.1120	.0940	.0759	44	.0860
40	.1120	.0958	.0795	43	.0890
48	.1120	.0985	.0849	42	.0935

5-9. Screw Thread - Continued

Table 5-10. Basic Coarse Thread Dimensions and Tap Drill Sizes - American Machine Screw - Continued

Nominal size	Outside diameter (in.)	Pitch diameter (in.)	Root diameter (in.)	Commercial tap drill to produce approx 75 percent full thread	Decimal equivalent of tap drill
Inch Threads per inch					
5-36	.1250	.1078	.0889	40	.0980
40	.1250	.1088	.0925	38	.1015
44	.1250	.1102	.0955	37	.1040
6-32	.1380	.1177	.0974	36	.1065
36	.1380	.1200	.1019	34	.1110
40	.1380	.1218	.1055	33	.1130
7-30	.1510	.1294	.1077	31	.1200
32	.1510	.1307	.1104	31	.1200
36	.1510	.1330	.1149	1/8	.1250
8-30	.1640	.1423	.1207	30	.1285
32	.1640	.1437	.1234	29	.1360
36	.1640	.1460	.1279	29	.1360
40	.1640	.1478	.1315	28	.1405
9-24	.1770	.1499	.1229	29	.1360
30	.1770	.1553	.1337	21	.1590
12-24	.2160	.1889	.1619	16	.1770
28	.2160	.1928	.1696	14	.1820
32	.2160	.1957	.1754	13	.1850

5-9. Screw Thread - Continued

Table 5-11. Basic Coarse Thread Dimensions and Tap Drill Sizes

Nominal size	Outside diameter (in.)	Pitch diameter (in.)	Root diameter (in.)	Commercial tap drill to produce approx 75 percent full thread	Decimal equivalent of tap drill
Inch Threads per inch					
1/16-64	0.0625	0.0524	0.0422	3/64	0.0469
72	.0625	.0535	.0445	3/64	.0469
3/64-60	.0781	.0673	.0563	1/16	.0625
72	.0781	.0691	.0601	52	.0635
3/32-48	0.0938	0.0803	0.0667	49	0.0730
50	.0938	.0808	.0678	49	.0730
7/64-48	.1094	.0959	.0823	43	.0890
1/8-32	.1250	.1047	.0844	3/32	.0937
40	.1250	.1088	.0925	38	.1015
9/64-40	.1406	.1244	.1081	32	.1160
5/32-32	.1563	.1360	.1157	1/8	.1250
36	.1563	.1382	.1202	30	.1285
11/64-32	.1719	.1505	.1313	9/64	.1406
3/16-24	.1875	.1604	.1334	26	.1470
32	.1875	.1672	.1469	22	.1570
13/64-24	.2031	.1760	.1490	20	.1610
7/32-24	.2188	.1919	.1646	16	.1770
32	.2188	.1985	.1782	12	.1890
15/64-24	.2344	.2073	.1806	10	.1935
1/4-20	.2500	.2175	.1850	7	.2010
24	.2500	.2229	.1959	4	.2090
27	.2500	.2260	.2019	3	.2130
28	.2500	.2268	.2036	3	.2130
32	.2500	.2297	.2094	7/32	.2187
5/16-18	.3125	.2764	.2403	F	.2570
20	.3125	.2800	.2476	17/64	.2656
24	.3125	.2854	.2584	I	.2720
27	.3125	.2884	.2644	J	.2770
32	.3125	.2922	.2719	9/32	.2812
3/8-16	.3750	.3344	.2938	5/16	.3125
20	.3750	.3425	.3100	21/64	.3281
24	.3750	.3479	.3209	Q	.3320
27	.3750	.3509	.3269	R	.3390
7/16-14	.4375	.3911	.3447	U	.3680
20	.4375	.4050	.3726	25/64	.3906
24	.4375	.4104	.3834	X	.3970
27	.4375	.4134	.3894	Y	.4040
1/2-12	.5000	.4459	.3918	27/64	.4219
13	.5000	.4501	.4001	27/64	.4219
20	.5000	.4675	.4351	29/64	.4531
24	.5000	.4729	.4459	29/64	.4531
27	.5000	.4759	.4519	15/32	.4687

## 5-9. Screw Thread - Continued

Table 5-11. Basic Coarse Thread Dimensions and Tap Drill Sizes - Continued

Nominal size	Outside diameter (in.)	Pitch diameter (in.)	Root diameter (in.)	Commercial tap drill to produce approx 75 percent full thread	Decimal equivalent of tap drill
Inch Threads per inch					
9/16-12	.5625	.5084	.4542	31/64	.4844
18	.5625	.5264	.4903	33/64	.5156
27	.5625	.5384	.5144	17/32	.5312
5/8-11	.6250	.5660	.5069	17/32	.5312
12	.6250	.5709	.5168	35/64	.5469
18	.6250	.5889	.5528	37/64	.5781
27	.6250	.6009	.5769	19/32	.5937
11/16-11	.6875	.6285	.5694	19/32	.5937
16	.6875	.6469	.6063	5/8	.6250
3/4-10	.7500	.6850	.6201	21/32	.6562
12	.7500	.6959	.6418	43/64	.6719
16	.7500	.7094	.6688	11/16	.6875
27	.7500	.7259	.7019	23/32	.7187
13/16-10	.8125	.7476	.6826	23/32	.7187
7/8-9	.8750	.8029	.7307	49/64	.7656
12	.8750	.8209	.7668	51/64	.7969
14	.8750	.8286	.7822	13/16	.8125
18	.8750	.8389	.8028	53/64	.8281
27	.8750	.8509	.8269	27/32	.8437
15/16-9	.9375	.8654	.7932	53/64	.8281
1-8	1.0000	.9188	.8376	7/8	.8750
12	1.0000	.9459	.8918	59/64	.9219
14	1.0000	.9536	.9072	15/16	.9375
27	1.0000	.9759	.9519	31/32	.9687
1 1/8-7	1.1250	1.0322	.9394	63/64	.9844
12	1.1250	1.0709	1.0168	1 3/64	1.0469
1 1/4-7	1.2500	1.1572	1.0644	1 7/64	1.1094
12	1.2500	1.1959	1.1418	1 11/64	1.1719
1 3/8-6	1.3750	1.2668	1.1585	1 7/32	1.2187
12	1.3750	1.3209	1.2668	1 19/64	1.2969
1 1/2-6	1.5000	1.3917	1.2835	1 11/32	1.3437
12	1.5000	1.4459	1.3918	1 27/64	1.4219
1 5/8-5 1/2	1.6250	1.5070	1.3888	1 29/64	1.4531
1 3/4-5	1.7500	1.6201	1.4902	1 9/16	1.5625
1 7/8-5	1.8750	1.7451	1.6152	1 11/16	1.6875
2-4 1/2	2.0000	1.8557	1.7113	1 25/32	1.7812
2 1/8-4 1/2	2.1250	1.9807	1.8363	1 29/32	1.9062
2 1/4-4 1/2	2.2500	2.1057	1.9613	2 1/32	2.0312
2 3/8-4	2.3750	2.2126	2.0502	2 1/8	2.1250
2 1/2-4	2.5000	2.3376	2.1752	2 1/4	2.2500

5-9. Screw Thread - Continued

Table 5-11. Basic Coarse Thread Dimensions and Tap Drill Sizes - Continued

Nominal size	Outside diameter (in.)	Pitch diameter (in.)	Root diameter (in.)	Commercial tap drill to produce approx 75 percent full thread	Decimal equivalent of tap drill
Inch Threads per inch					
2 3/4-4	2.7500	2.5876	2.4252	2 1/2	2.5000
3-3 1/2	3.0000	2.8145	2.6288	2 23/32	2.7187
3 1/4-3 1/2	3.2500	3.0645	2.8788	2 31/32	2.9687
3 1/2-3 1/4	3.5000	3.3002	3.1003	3 3/16	3.1875
3 3/4-3	3.7500	3.5335	3.3170	3 7/16	3.4375
4-3	4.0000	3.7835	3.5670	3 11/16	3.6875

5-10. Wire Gage.

a. The size of wire may be designated either by gage number or by its diameter in mils. Usually the size of wire less than one-half of an inch in diameter is stated in gage number. Wire larger than one-half of an inch in diameter usually is described in terms of its diameter in mils (one-thousandth of an inch) or in terms of its cross-sectional area in circular mils. The size (gage number) of a solid wire refers to the cross-section of the wire perpendicular to its length. The size or gage number of a stranded wire refers to its total cross-section

b. American Wire Gage is commonly used in the United States for copper and aluminum wire and in general for wire used in electrical work. It is designated by the abbreviation AWG.

c. Data on the relations of length, mass, and resistance of annealed copper wire in abbreviation AWG. American Wire Gage sizes is listed in table 5-12.

Table 5-12. Annealed Copper Wire Data

Gage no. (AWG)	Diameter in mils at 20°C	Cross-section at 20°C		Ohms per 1000 feet		
		Circular mils	Square inches	0°C (32° F)	20°C (68° F)	75° C (167° F)
0	324.8	105,500	.08289	.09055	.09827	.1195
2	257.6	66,370	.05213	.1440	.1563	.1900
4	204.3	41,740	.03278	.2289	.2485	.3022
6	162.0	26,250	.02062	.3640	.3951.	.4805
8	128.5	16,510	.01297	.5788	.6282	.7640



5-10. Wire Gage - Continued

Table 5-12. Annealed Copper Wire Data - Continued

Gage no. (AWG)	Diameter in mils at 20°C	Cross-section at 20°C		Ohms per 1000 feet		
		Circular mils	Square inches	0°C (32° F)	20°C (68° F)	75° C (167° F)
10	101.9	10,380	.008155	.9203	.9989	1.215
12	80.81	6530	.005129	1.463	1.588	1.931
14	64.08	4107	.003225	2.327	2.525	3.071
16	50.82	2583	.002028	3.700	4.016	4.884
18	40.30	1624	.001276	5.883	6.385	7.765
20	31.96	1022	.0008023	9.355	10.15	12.35
22	25.35	642.4	.0005046	14.87	16.14	19.63
24	20.10	404.0	.0003173	23.65	25.67	31.22
26	15.94	254.1	.0001996	37.61	40.81	49.64
28	12.64	159.8	.0001255	59.80	64.90	78.93

Resistance at the stated temperatures of a wire whose length is 1,000 feet at 20° C.

5-27/(5-28 blank)

**CHAPTER 6**  
**CABLES, HARNESES, AND CONNECTORS**

**Section I. FABRICATION OF WIRING HARNESES**

**6-1. General.**

The majority of wiring harnesses for fire control equipment are included in the pertinent supply manual. The remaining harnesses will be fabricated from bulk wire as specified in the applicable rebuild instructions. This section describes wire preparation, pin board use, wire coding, and harness lacing

**6-2. Preparing Wires.**

Cut the wire to the lengths listed in the wiring diagram referenced in the applicable instructions (lengths specified are for wires before attaching terminals). The type and size of wires are in the listing. Strip the wires as specified and tin the ends of all wires to which terminal lugs are to be soldered. In stripping the insulation, do not nick the wires.

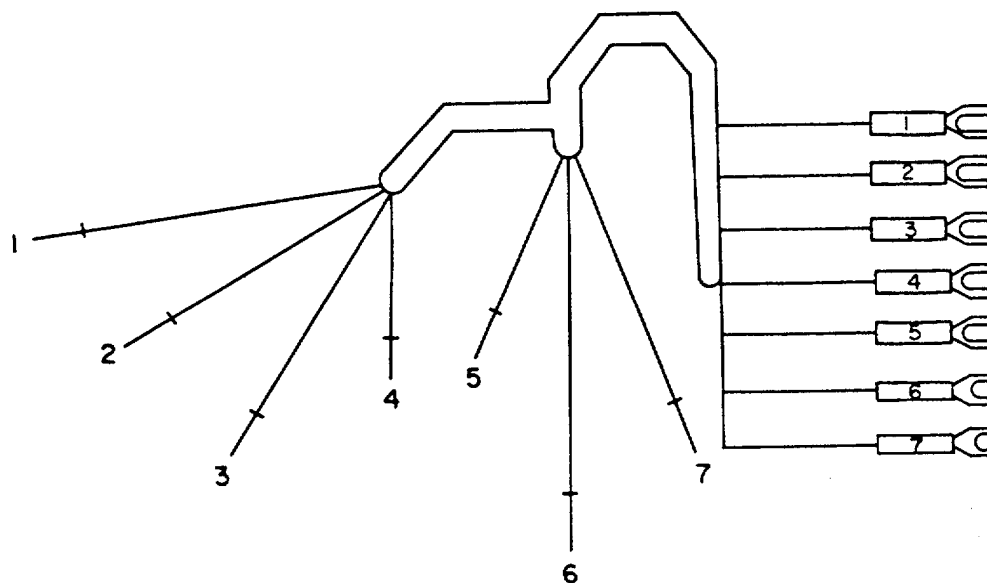

**NOTE:**  
SINGLE CORD DOUBLE RUNNING  
LOCKSTITCH 1/2 IN. SPACING.

*Figure 6-1. Typical Wiring Harness Diagram*

**6-3. Use of Pin Boards.**

Pin boards are used to shape the wires for binding into a harness. Figure 6-2 shows a typical pin board diagram. The pin board diagrams of wiring harnesses for fire control equipment appear in the pertinent technical manual. Reference is made to these diagrams as applicable in the rebuild instructions. Individual wire routing for the boards will be found on the applicable wiring harness diagram. Cut and stamp marker sleeves to suit from bulk sleeve material.

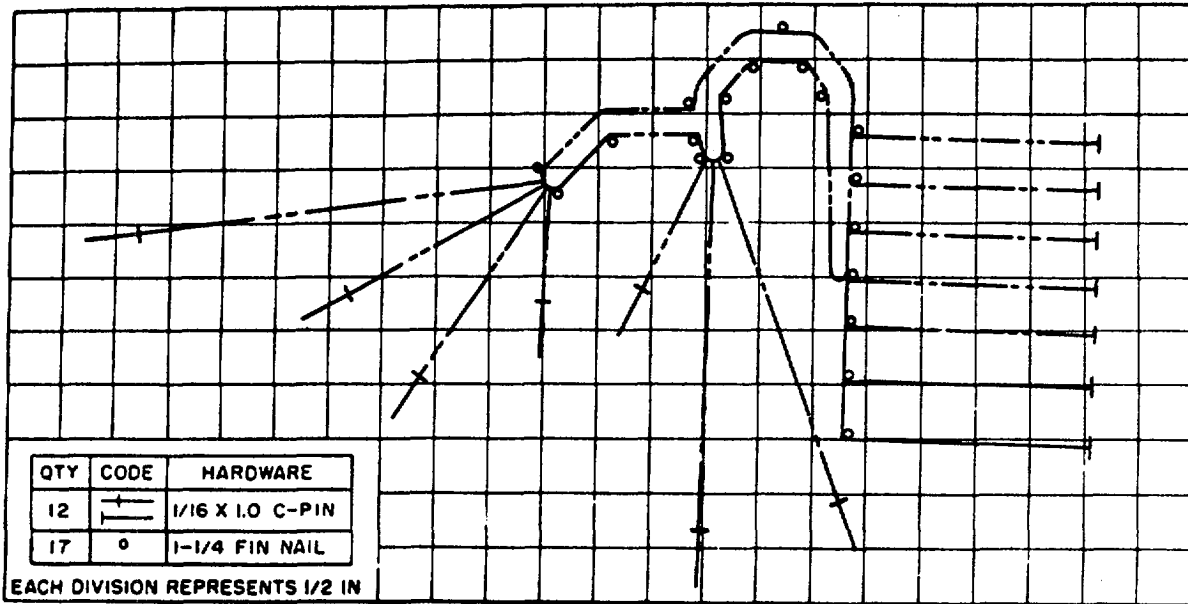

Figure 6-2. Typical Pin Board Diagram

**6-4. Coding Wires.**

Fit marker sleeves on the conductors in such a manner that the identifying characters can easily be read from one direction when the wiring has been installed in the equipment. In the case of two rows of connections, on opposite sides of the terminal block, it may be more practical to arrange the sleeves so they may be read from opposite directions. However, all the sleeves in each individual row should read from a single direction. The position of the sleeve designation will be shown in the wiring harness diagram referenced in the applicable rebuild instructions

**6-5. Harness Lacing.**

a. Starting Stitch (fig. 6-3). Continuous lacing of a cable harness shall begin with a starting stitch. Determine the approximate diameter of the cable harness being laced. Spacing between the lacing stitches, in a continuous lace, should be between one and two times the diameter of the cable harness. In no case should the distance between the lacing stitches exceed 1 inch.

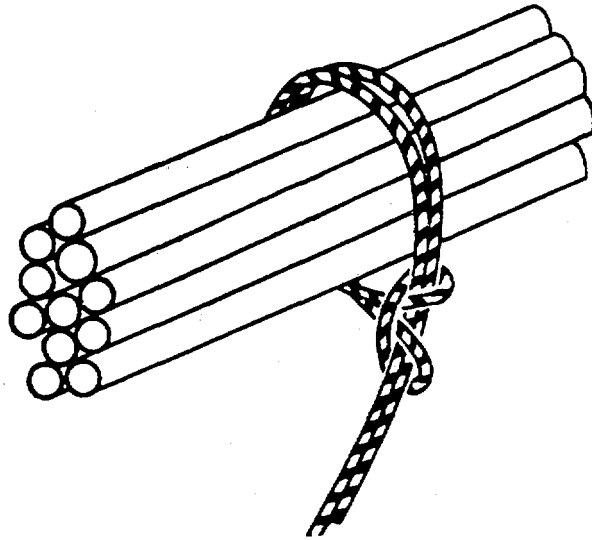

*Figure 6-3. Lacing Starting Stitch*

b. Running Lock Stitch (fig. 6-4). After beginning with a starting stitch, form a series of running lock stitches along the length of the cable harness. Always keep the lacing stitches on the same side of the cable harness when forming the lacing run. Wherever a breakout occurs, make a running lock stitch at a point prior to the wire leaving the harness.

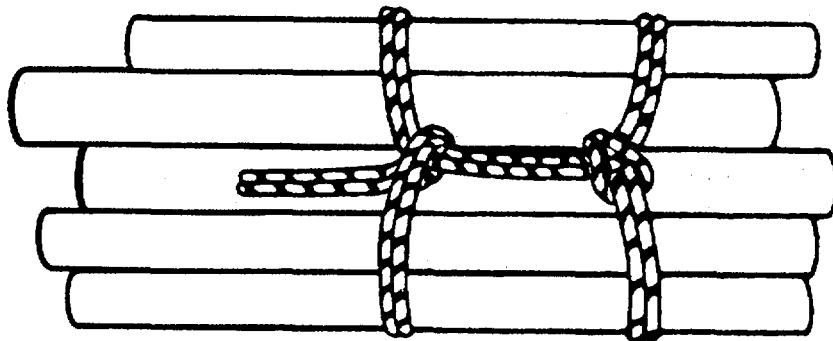

*Figure 6-4. Running Lock Stitch*

**6-5. Harness Lacing - Continued**

c. Finishing Square Knot (fig. 6-5). The finishing knot should be a typical finishing square knot although the lacing frequently will finish off on one wire rather than on the body of the harness as shown.

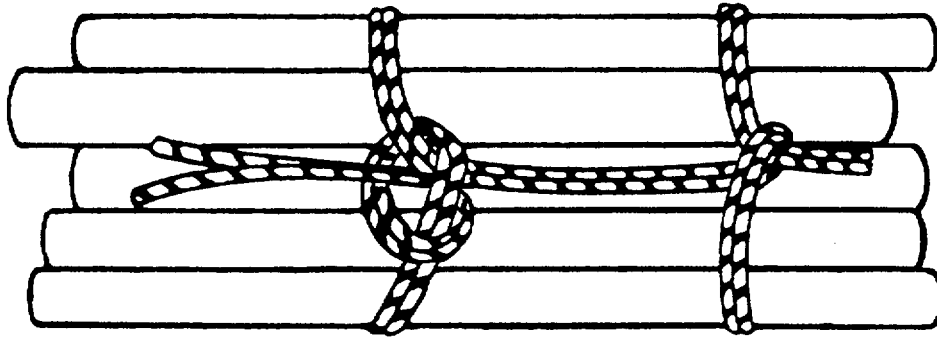

*Figure 6-5. Finishing Square Knot*

d. Spot Ties (fig. 6-6). Use a clove hitch for spot ties on cable harness where continuous lacing is not desired. The applicable wiring harness diagram will specify the type of lacing stitch and stitch spacing for the harness.

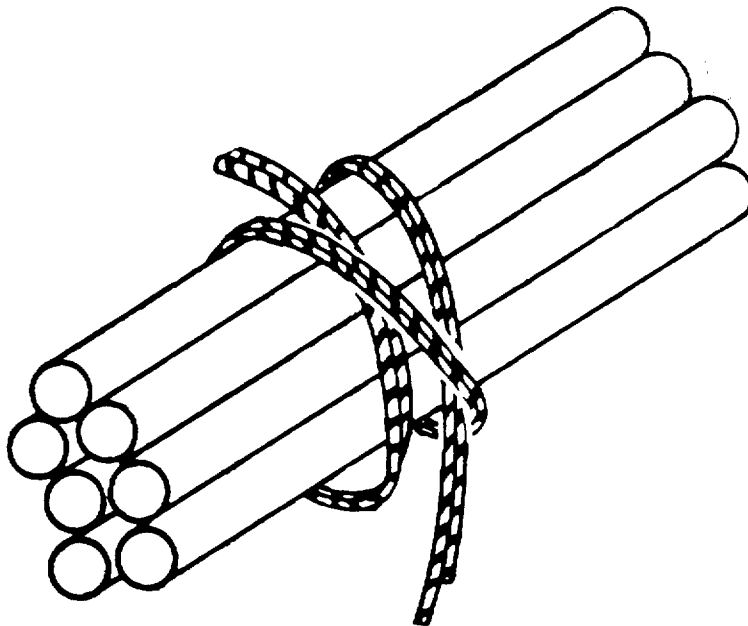

*Figure 6-6. Clove Hitch Spot Tie*

Section II. CABLE CONNECTORS

6-6. General.

When selecting connectors, there are three main characteristics to consider: the size of the cable, the method of coupling or mating, and the method of cable retention. The three methods of attaching the connector to the cable are: soldering, clamping, and crimping.

6-7. Connector Familiarization.

a. Types of Cable Connectors (fig. 6-7). There are many types of connectors such as:

- (1) Terminal lugs (1).
- (2) Push or pull rubber connectors (2).
- (3) Twist type quick disconnect connectors with receptacle (3) and plug (4).
- (4) Screw type connectors with receptacle (5) and plug (6).

b. Advantages and Disadvantages. There are advantages and disadvantages with each type of connector. Some are apparent, such as the ease of connecting a push or pull connector compared to a threaded screw type connector. Some are not so apparent such as circuit noise generated by a twist type quick disconnect connector.

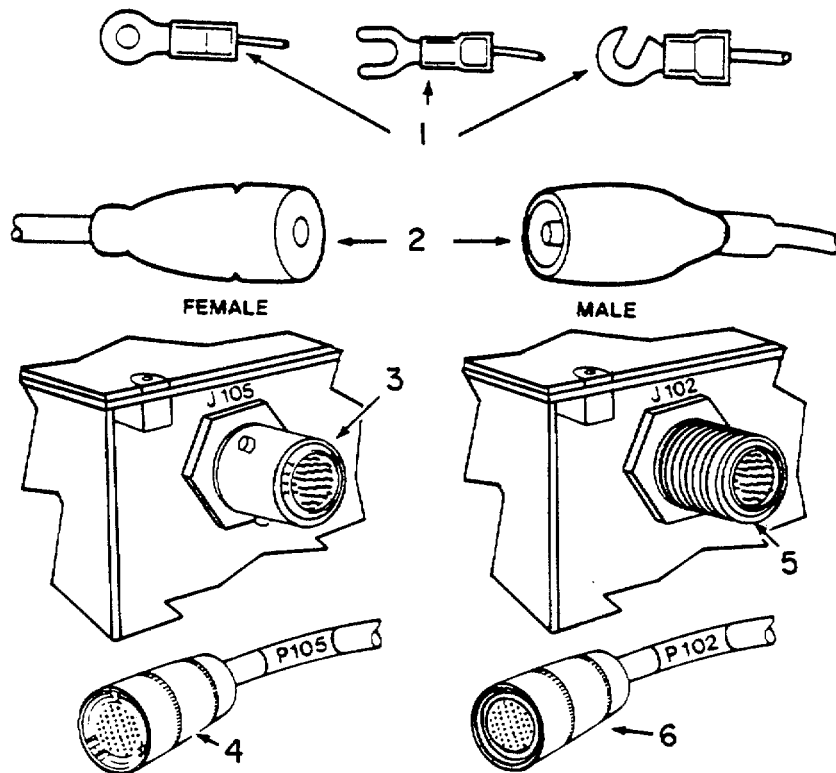

Figure 6-7. Types of Cable connectors

## 6-8. Connector Maintenance.

a. Female Single Lead Connector (fig. 6-8). The following is a recommended maintenance procedure for a female single lead connector

### WARNING

**To avoid electrical shock to personnel, make sure that all electrical power is turned OFF when cleaning, inspecting, and repairing electrical cables, contacts, and connectors.**

- (1) Using long nose pliers (1), pull female contact (2) clear of its shell (3).
- (2) If contact (2) is cracked, bent, or corroded; clean, repair, or replace.
- (3) If the crimp or solder is loose on contact (2), or if lead (4) is worn or torn; repair or replace.
- (4) If contact (2) is only dirty, clean with a swab dampened with alcohol.
- (5) Place contact (2) back in its shell (3) by sliding shell up over contact (2).

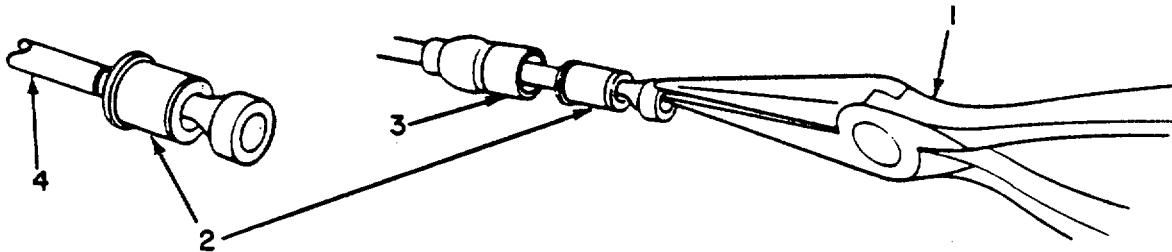

*Figure 6-8. Female Single Lead Connector*

b. Male Single Lead Connector (fig. 6-9). The following is a recommended maintenance procedure for a male single lead connector.

### WARNING

**To avoid electrical shock to personnel, make sure that all electrical power is turned OFF when cleaning, inspecting, and repairing electrical cables, contacts, and connectors**

- (1) Using long nose pliers (1), pull male contact (2) out of its shell (3).

### 6-8. Connector Maintenance Continued

- (2) If contact (2) is cracked, bent or corroded; clean, repair, or replace.
- (3) If the crimping or solder is loose on contact (2), or if lead (4) is worn or torn; repair or replace.
- (4) If retainer (5) is missing, replace it.
- (5) If contact (2) is only dirty, clean with a swab dampened with alcohol.
- (6) Place contact (2) back in its shell (3) by sliding shell up over contact (2).

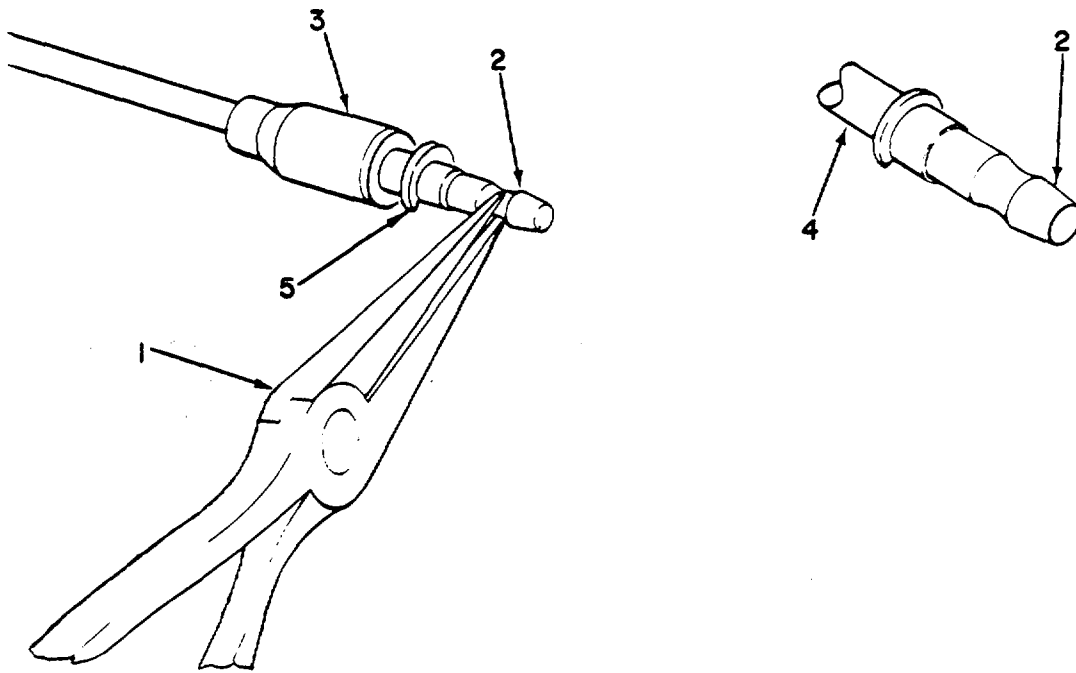

Figure 6-9. Male Single Lead Connector

- c. Straight Plug Connector (fig. 6-10). The following is a recommended maintenance procedure.

#### WARNING

**To avoid electrical shock to personnel, make sure that all electrical power is turned OFF when cleaning, inspecting, and repairing electrical cables, contacts, and connectors**

- (1) Using a flat tip screwdriver, loosen two screws (5) on shell (6).
- (2) Hold plug (1) tightly in one hand, unscrew shell (6), and pull shell back.



**6-8. Connector Maintenance - Continued**

- (3) If solder wells or contacts (2) are cracked, bent, or corroded; clean, repair, or replace.
- (4) If wire ends or leads (4) are worn or torn; clean, repair, or replace.
- (5) If contacts (3) are dirty, clean with a swab dampened with alcohol.
- (6) Hold plug (1) tightly in one hand and screw shell (6) onto plug.
- (7) Using a flat tip screwdriver, tighten two screws (5) on shell (6).

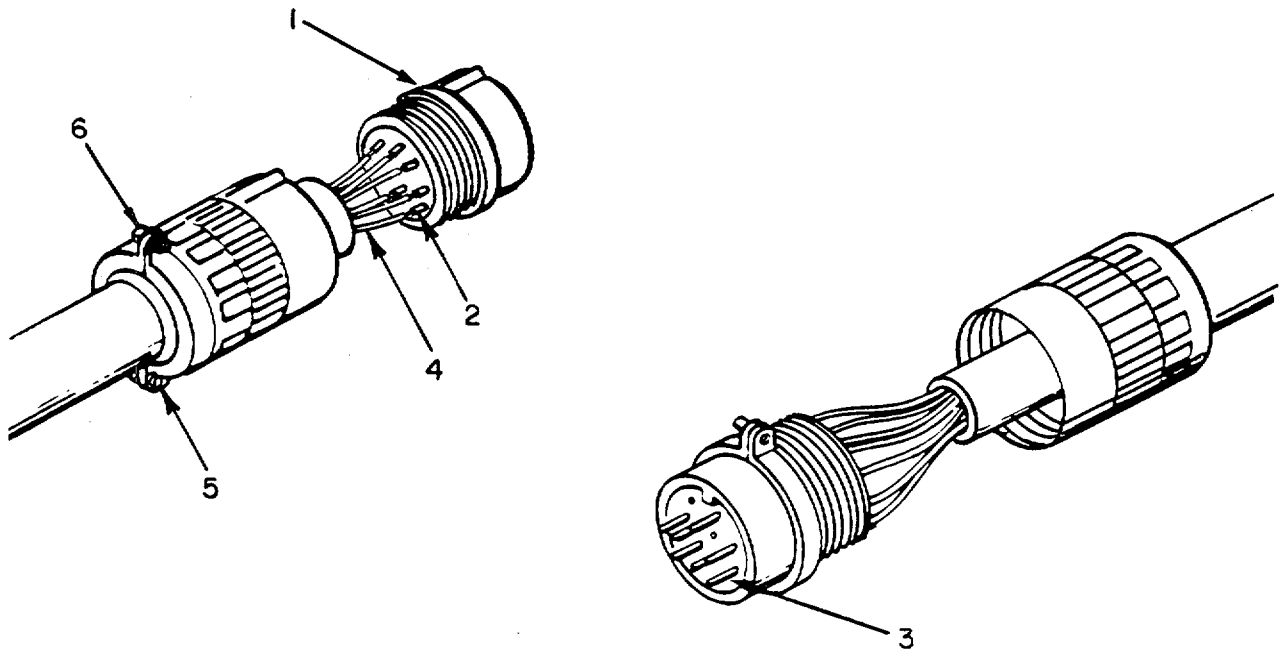

Figure 6-10. Straight Plug Connector

**6-9. Solderless Connectors.**

a. General. Wires connected to solderless connectors must be mechanically secure to insure positive electrical contact. Solder coated wires may not be crimped in solderless connectors. Select a connector which will accommodate the wire and insulation properly. The eye must be large enough to accommodate the terminal screw or stud.

b. Insulated Solderless Connectors (fig. 6-11). When insulated solderless connectors are used, observe the following requirements.

- (1) The conductor insulation should seat against the shoulder of the wire barrel.
- (2) The end of the center conductor extends beyond the wire barrel but not beyond the outer circumference of the eye portion.

6-9. Solderless Connectors - Continued

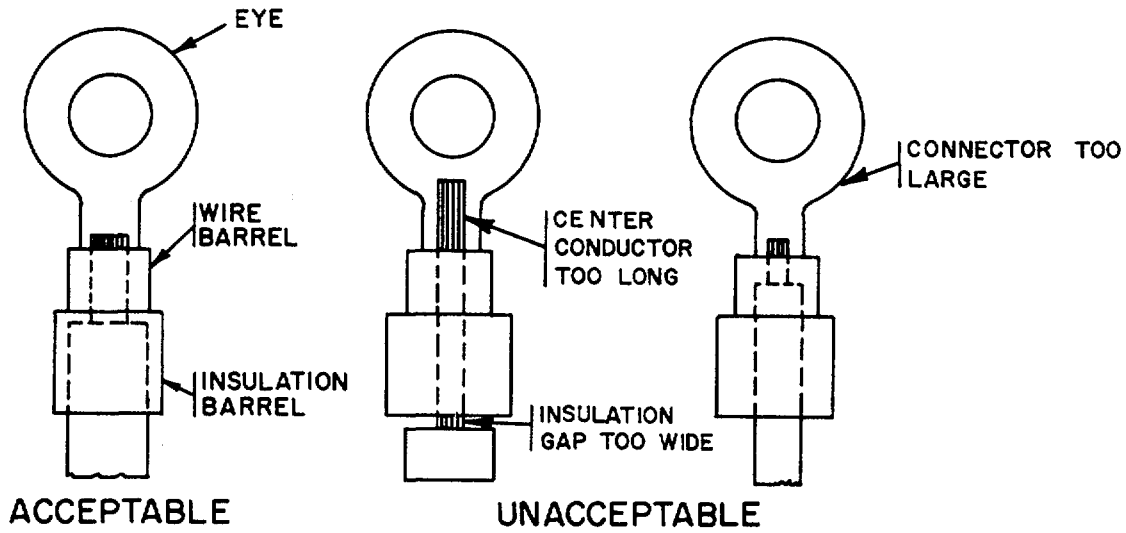

Figure 6-11. Insulated Solderless Connector

c. Uninsulated Solderless Connectors (fig. 6-12). When uninsulated solderless connectors are used, observe the following requirements.

- (1) The center conductor of the wire fits snugly in the barrel with the end of the center conductor extending beyond the barrel but not beyond the outer circumference of the eye portion.
- (2) The insulation gap between the uninsulated connector and the conductor insulation should not exceed a distance that is equal to the diameter of the conductor, including the insulation.

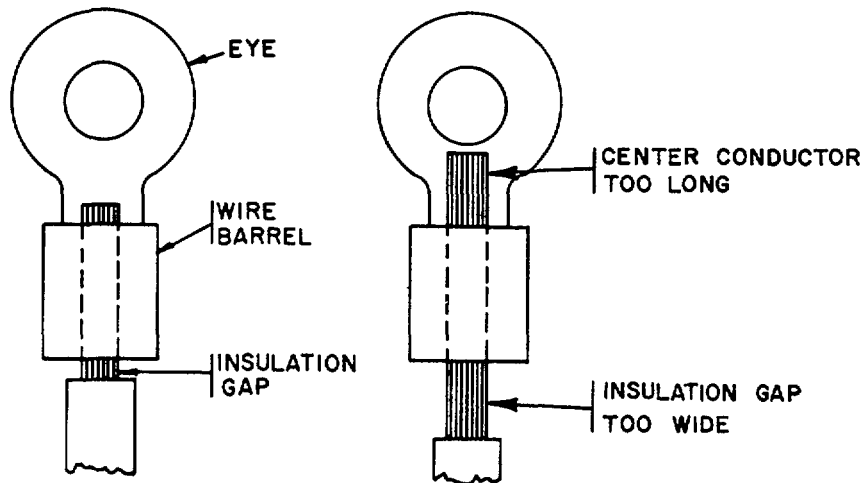

Figure 6-12. Uninsulated Solderless Connector

## 6-9. Solderless Connectors Continued

d. Installing Solderless Connector (fig. 6-13). The proper method of connecting wires to solderless connectors is as follows:

- (1) Slide conductor wire into terminal barrel as shown in figure 6-12.

### NOTE

**Crimping tools are sized according to the size of wire connector being crimped. Always use the proper size crimping tool**

- (2) Place terminal barrel into crimping tool jaws and squeeze the handles of the crimping tool firmly so that the crimping tool causes a depression in the terminal barrel.
- (3) Release pressure on the handles and remove crimped terminal from the crimping tool.

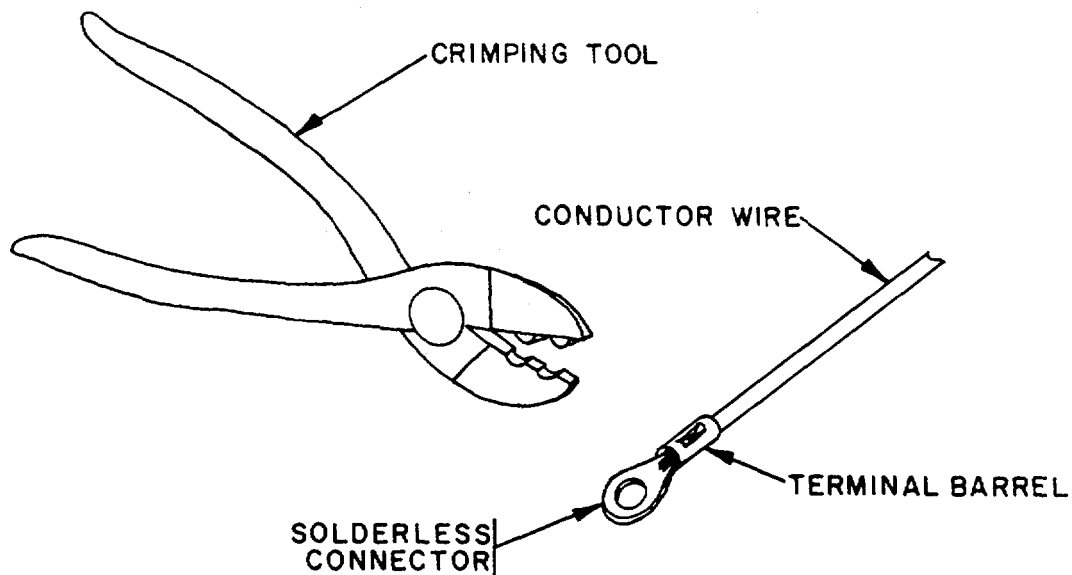

Figure 6-13. Crimping a Solderless Connector

e. Crimping Requirements (fig. 6-14). Inspect the connector for acceptable crimping. The crimp must not extend to the edge of the connector barrel. The connector barrel must not be cracked or distorted.

6-9. Solderless Connectors - Continued

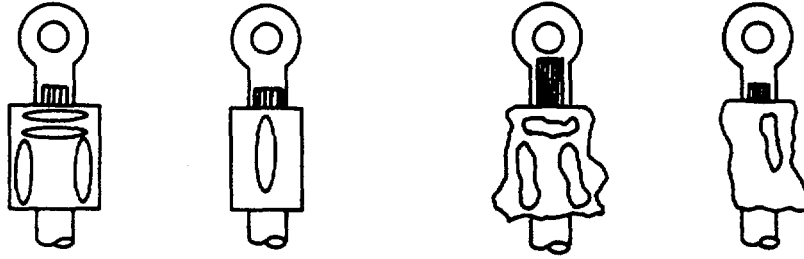

Figure 6-14. Crimping Requirements for Solderless Connectors

6-10. Connector Contact Pins

a. General. Multi-pin connector plugs vary according to the manufacturer and their intended use. The following will describe how to remove and install the most commonly used connector contact pins.

b. Removal of Front Release Connector Contact (fig. 6-15).

- (1) Select the correct extraction tool according to the type of pin to be extracted.

**CAUTION**

The tool must be held in a straight line, parallel to the contact and square to the connector face. To avoid damage to the tool or the connector, do not tip, spread, or rotate the tool while over the connector contact

**NOTE**

The plunger slide must remain in the retracted position as the removal tool tip is inserted into the connector.

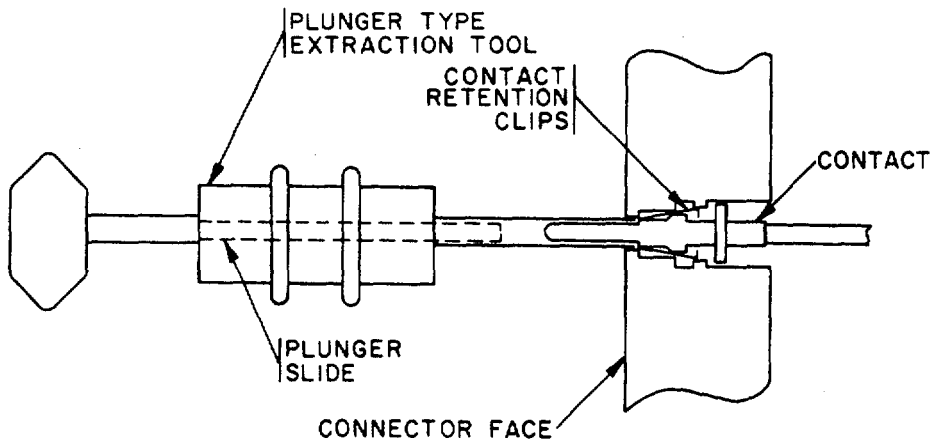

Figure 6-15. Removal of Front Release Connector Contact

**6-10. Connector Contact Pins Continued**

- (2) Insert the removal tool tip over the contact with a firm pressure until the removal tool tip bottoms out against the contact. This will release the contact retention clips that secure the contact into the connector.
- (3) Push in on the plunger slide to eject the contact from the rear of the connector.

c. Installation of Front Release Connector Contact (fig. 6-16).

- (1) Using the proper size insertion tool, push the contact through the rear side of the plug until it bottoms in the plug cavity. This will seat the contact retention clips in the plug cavity.
- (2) Lightly but firmly pull back on the contact barrel with the needle nose pliers. If the contact retention clips have seated, the contact can not be pulled from the plug. If the contact retention clips have not seated, repeat step (2).

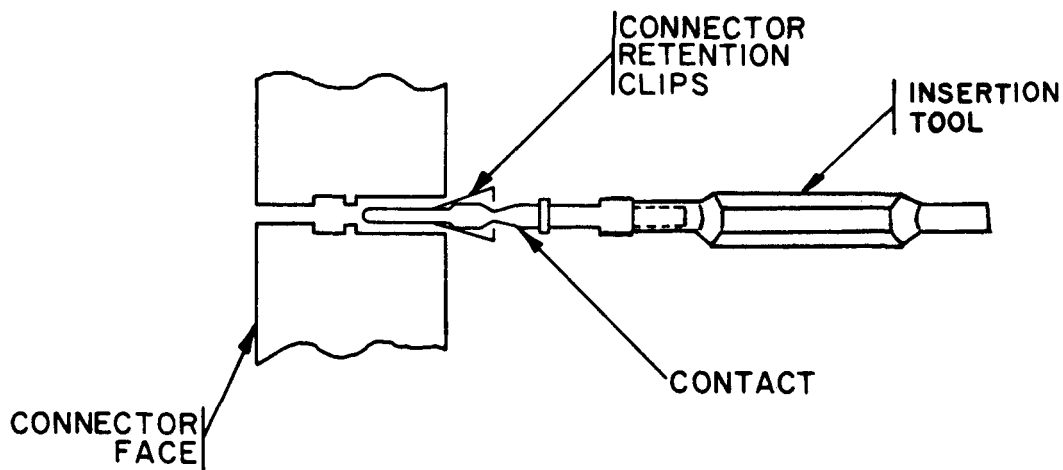

Figure 6-16. Installation of Front Release Connector Contact

d. Removal of Termi-Twist Contacts (figs. 6-17 and 6-18).

- (1) Select the correct tool for the contact to be removed (table 6-1).

6-10. Connector Contact Pins Continued

Table 6-1. Termi-Twist Contact Tools

NSN/Mfg. tool stock number	Contact size
5120-00-156-8630 (AMP 265831-1)	0.002 x 0.036 inch
5120-00-494-6767 (AMP 265831-3)	0.031 x 0.062 inch

- (2) Slip the tip of the tool over the exposed contact (fig. 6-17). Insure that the tip of the tool bottoms on the post side of the connector

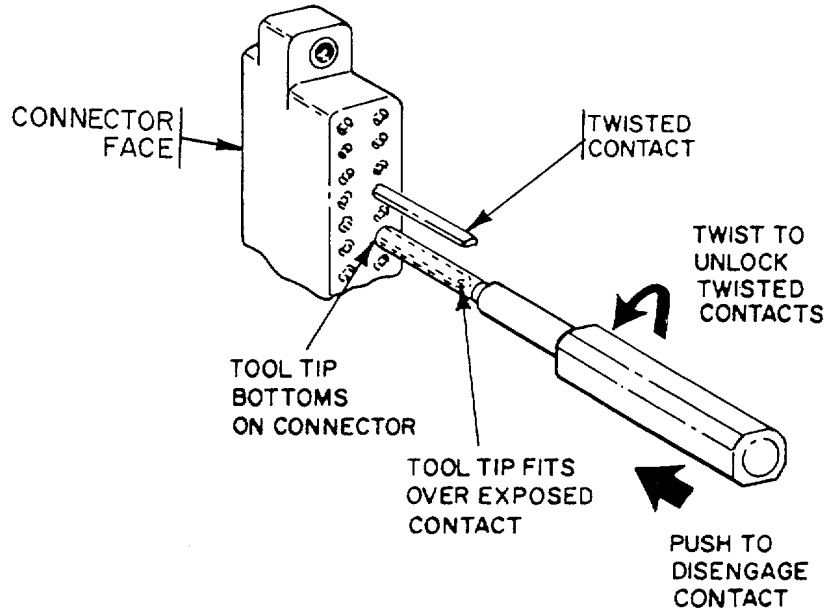

Figure 6-17. Termi-Twist Contact Removal Preparation

- (3) Twist the contact 90 degrees counterclockwise to unlock the contact.
- (4) Push on the handle to disengage the contact. Pull the contact from the connector face side with the needle nose pliers (fig. 6-18).
- (5) Discard the removed contact.

6-10. Connector Contact Pins -.Continued

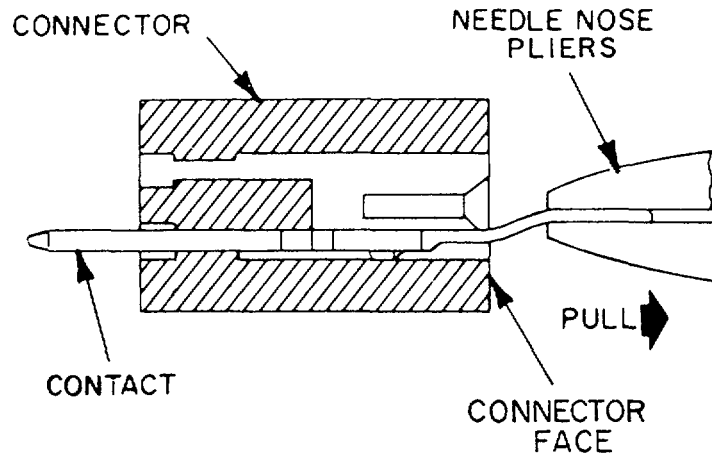

Figure 6-18. Termi-Twist Contact Removal

e. Installation of Termi-Twist Contact (figs. 6-19, 6-20, and 6-21).

- (1) Insert the contact into the connector as shown in figure 6-19.

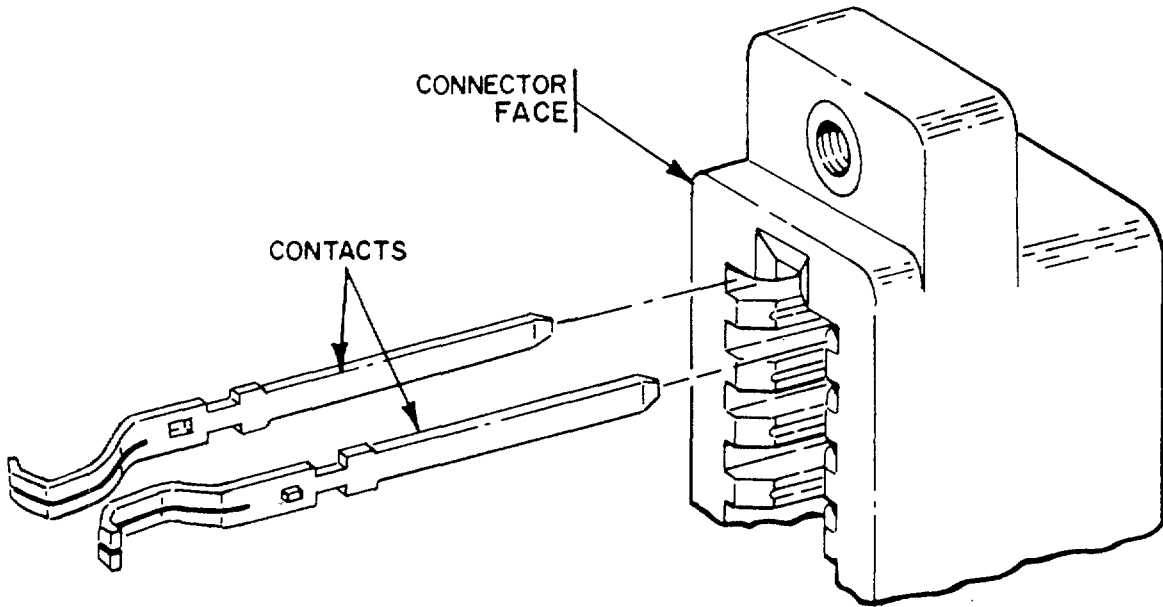

Figure 6-19. Termi-Twist Contact Installation

6-10. Connector Contact Pins - Continued

**CAUTION**

Needle nose plier jaws must be free of all serrations to prevent damage to the contact and its plating.

- (2) Apply masking tape over the needle nose plier jaw serrations, and grasp the post side of the contact with the needle nose pliers. Pull the contact, with the needle nose pliers, until it bottoms in the connector cavity (fig. 6-20).

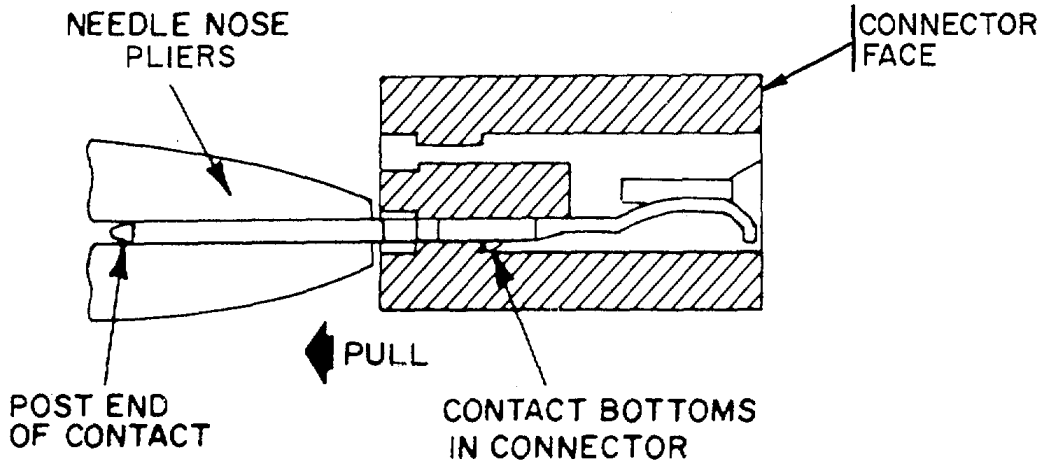

Figure 6-20. Termi-Twist Contact Bottoming

- (3) Slip the tip of the tool over the contact, and rotate the contact 90 degrees clockwise to lock it in position (fig. 6-21).

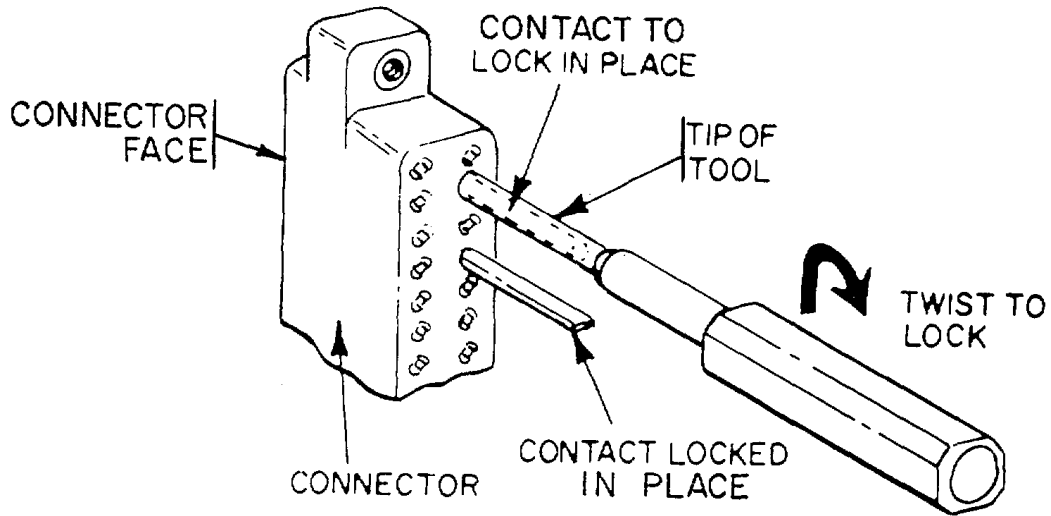

Figure 6-21. Termi-Twist Contact Locking



**6-10. Connector Contact Pins - Continued**

- (4) Check the connector to be certain that the new contact is aligned with the adjacent contacts.

**Section III. SAFETY WIRING TECHNIQUES****6-11. Safety Wiring Procedures.**

- a. Basic Procedures. The following basic procedures should be followed when installing safety wire.

- (1) Safety wire must be tight after installation to prevent failure due to rubbing or vibration.
- (2) Safety wire must always be installed so that it tends to tighten the part, thereby counteracting the natural tendency of the part to loosen. Determine whether the part tightens when turned to the right or to the left, as this governs the direction in which safety wire is to be threaded through the safety hole. Figure 6-22 illustrates typical methods for safety wiring of right-hand threaded parts. Use the reverse procedure for left-hand threaded parts.
- (3) Safety wire must never be overstressed. When tightening the safety wire, twist it enough to insure the securing of the part, but not so much that the wire becomes stressed to a point where it will break under a slight load.
- (4) Handle safety wire during installation so that the strands do not become kinked, nicked, or flattened. Avoid pulling the wire around square corners or gripping it too tightly with tools.
- (5) Make certain safety holes are exposed as much as possible and that parts are properly tightened before installing safety wire. However, parts should not be loosened or torqued beyond the specified values in order to improve the location of safety holes. Do not use or drill unspecified safety holes.
- (6) Never twist the wire ends off with pliers. Cut the ends square to eliminate sharp points, leaving from three to six turns after the loop. Do not allow cut off ends to fall into the parts being safety wired.
- (7) Safety wire ends must be bent in toward the item being safety wired to prevent possible injury to the mechanic's hands.

**NOTE**

**Safety wire must never be reused.**

- (8) Use double safety wire (fig. 6-22) in all cases except for emergency equipment.

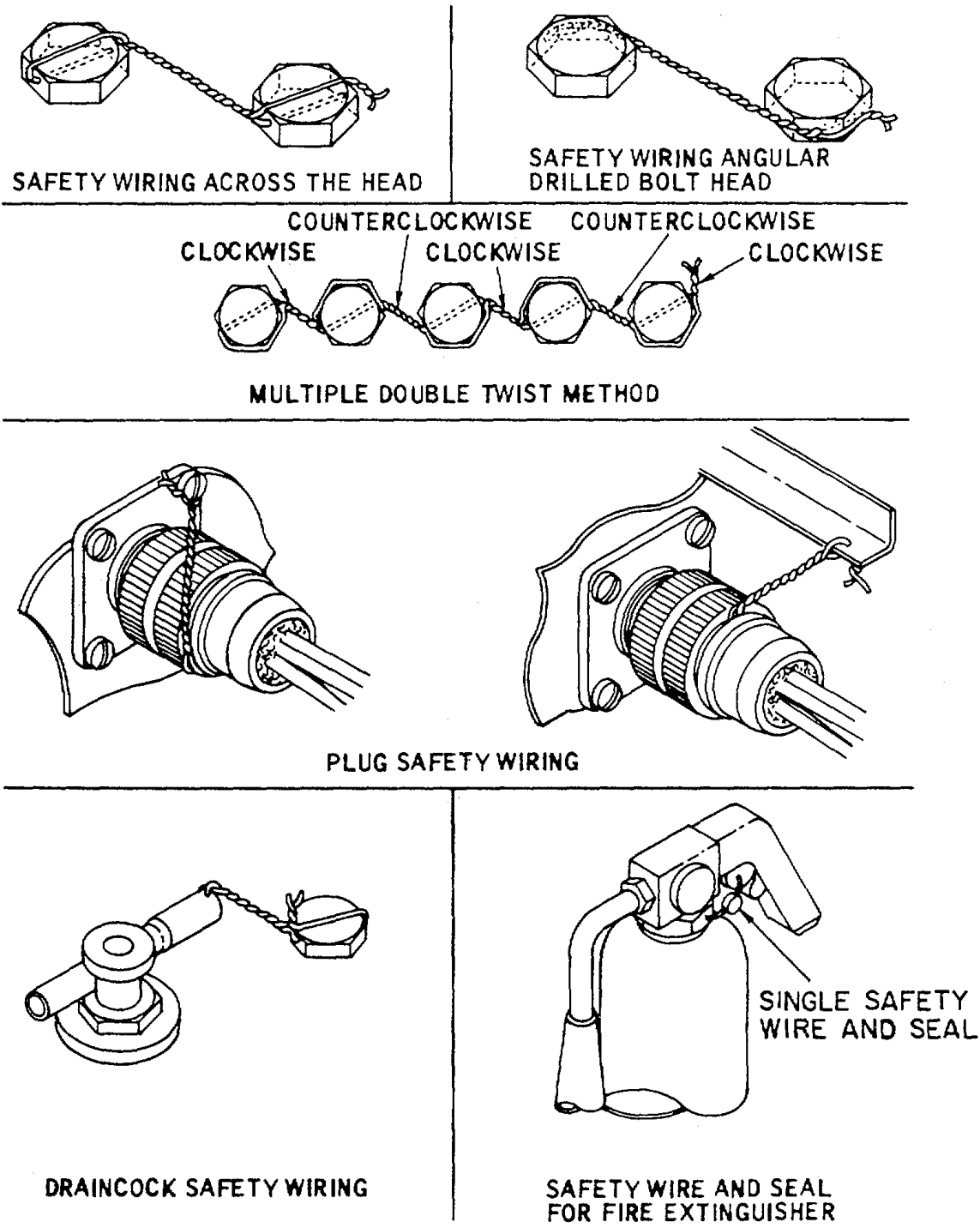

Figure 6-22. Safety Wire Applications

6-11. Safety Wiring Procedures - Continued

- (9) Use single safety wire (fig. 6-22) for emergency equipment. When used on emergency equipment, safety wire must perform its function of preventing parts from moving or separating and must also be capable of being broken easily when the equipment is needed. Examples of such usage are emergency exits, emergency air brake levers, fire extinguishers, and snap slides. Table 6-2 lists the types of safety wire and their uses.

Table 6-2. Safetywire

Safety wire		Identification No.	Specification	Use
Material	Diameter			
Nick-Chromium-Iron Alloy	0.032	MS20995N32	QQ-W-390 Condition A	General purpose, storage, bolts, nuts, drain plugs and cocks, cable stops in temperatures above 450°F, corrosive areas, and electrical equipment.
Nick-Chromium-Iron Alloy	0.020	MS20995N20	QQ-W-390	Turnbuckles: up to 1/16 of an inch diameter cable, 3/32 of an inch to 5/32 of an inch diameter cable, 5/32 of an inch diameter, or larger, cable.
Corrosion resistant steel	0.047	MS20995N47	QQ-W-423 Condition A Type 302	Special high-strength applications.
Bare copper	0.020	MS20995CU20	QQ-W-343	Emergency parts, exits, air brake levers, and fire extinguishers.

- b. Safety Wire Installation. The following is a recommended procedure for installing safety wire.

6-11. Safety Wiring Procedures - Continued

NOTE

Steps (1) through (4), refer to figure 6-23.

- (1) Screws, nuts, and bolts made for lockwiring have one or more holes (1) for the insertion of safety wire.
- (2) To install safety wire, plan a path (2) and determine the length of wire needed to do the job.
- (3) Insert safety wire (3) through the hole (4) of the first screw, to about the middle of the length of wire being used.
- (4) Bend wire end around the right side of screwhead (5).

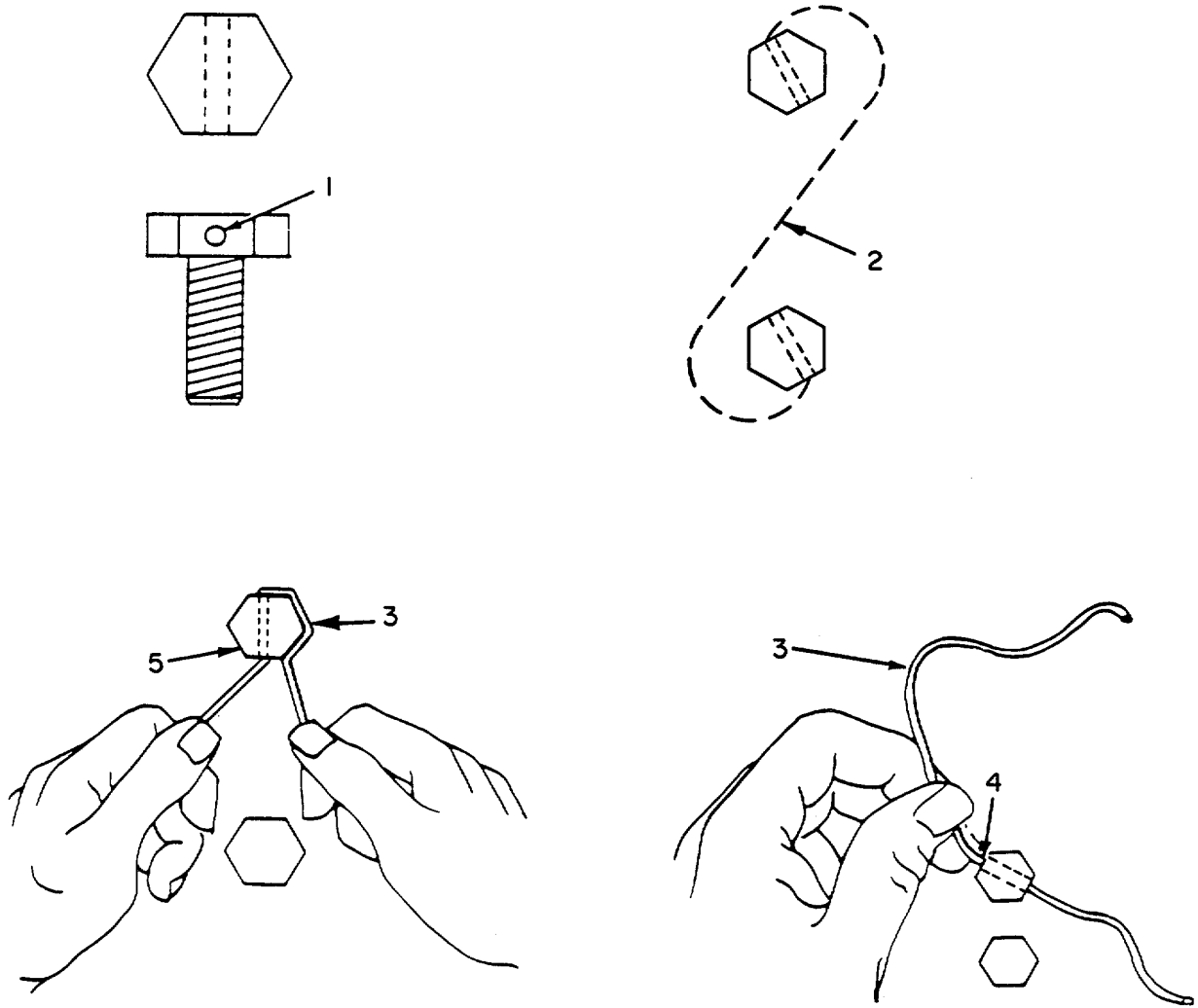

Figure 6-23. Safety Wire Installation

6-11. Safety Wiring Procedures - Continued

NOTE

Steps (5) through (9) refer to figure 6-24.

- (5) At each screwhead, bring wire end on left (1) over top of right-hand wire. Using wiretwisting pliers (2), twist wire until it just reaches the next screwhead.
- (6) If wiretwisting pliers are not available, safety wire may be twisted by hand (3).
- (7) Push top wire (4) through hole in screwhead. Bend bottom wire (5) around left side of screwhead to meet wire (4) coming out of hole in screwhead.
- (8) Bring wire end (5) over top of right-hand wire (4) and twist wire about four or five turns (6) beyond the last screwhead.
- (9) Using diagonal cutting pliers (7), cut off end of wires leaving about four or five turns beyond last screwhead.

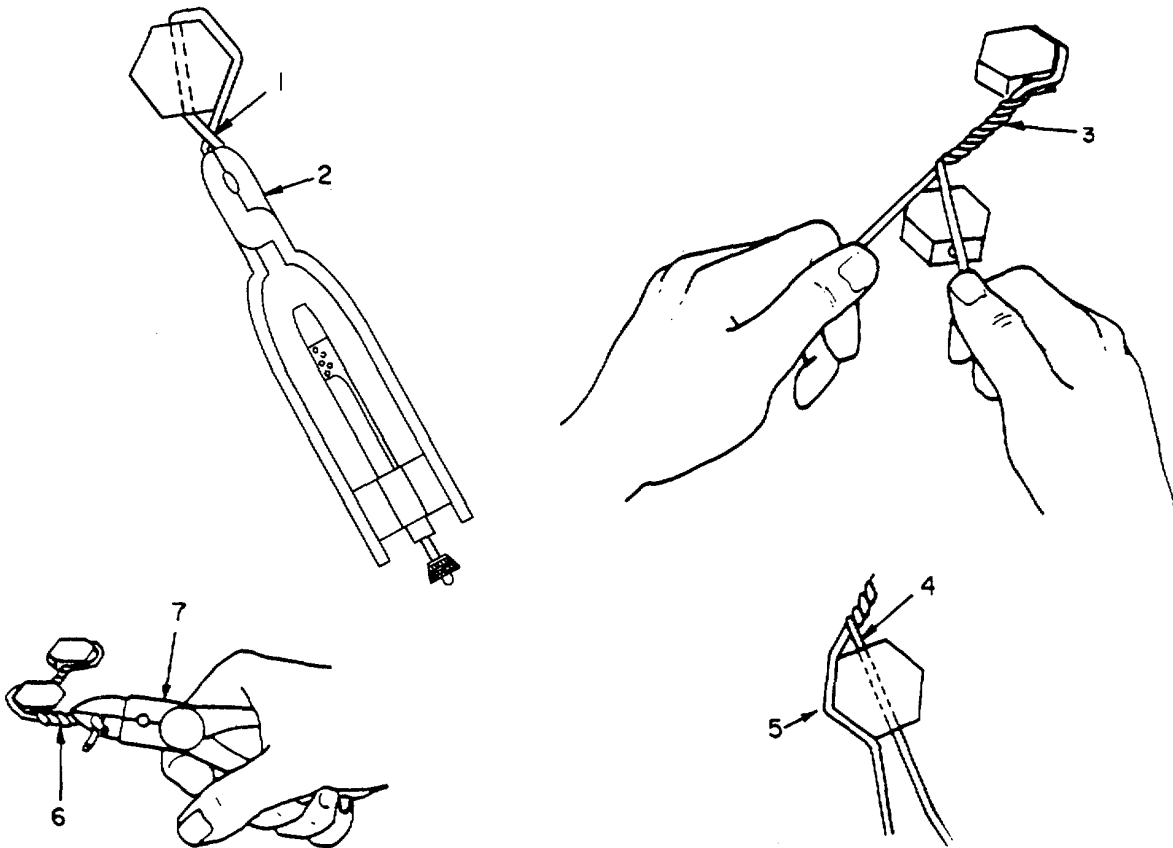

Figure 6-24. Safety Wiring Installation - Multiconnection

## Section IV. TAGGING WIRES AND LOOSE PARTS DURING DISASSEMBLY

### 6-12. General.

When performing maintenance tasks, it often becomes necessary to loosen and disconnect wires or parts of certain items to gain access to other areas where the maintenance task is to be performed. Before removal of such wires or parts it is recommended that they be tagged to help remember their proper location after they have been disassembled.

### 6-13. Tagging.

a. General. Make a tag by cutting a piece of masking tape of convenient size for the wire or part being identified. On this tag write the part number, connector and pin number, terminal strip and terminal number, or some other method of identifying the item being removed.

b. Item Tagging (fig. 6-25). A recommended procedure for tagging wires is as follows:

- (1) Remove wire (1) from its terminated location on the terminal board.

#### NOTE

**Tag should stick to wire so the marking can easily be read.**

- (2) Mark the wire by wrapping tag (2) around wire (1) before removing next wire.

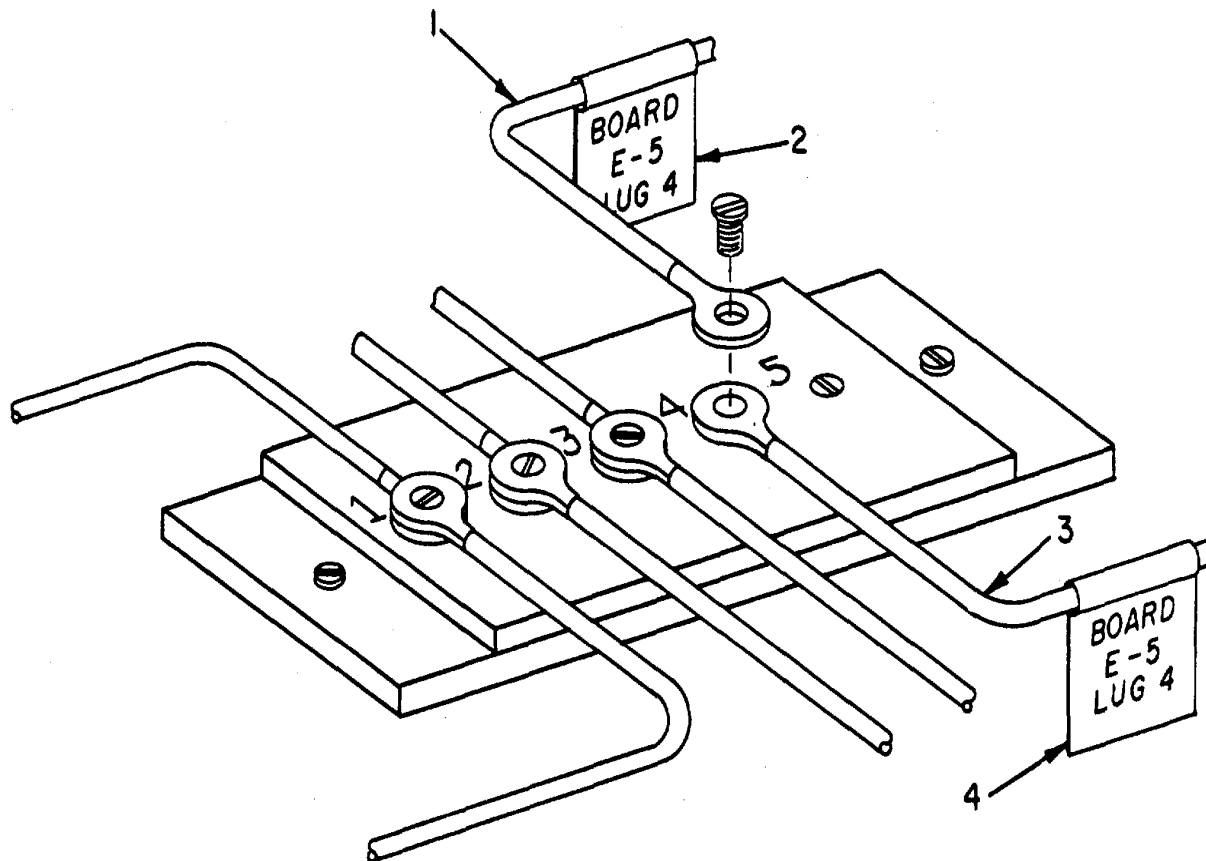

Figure 6-25. Item Identification Tags

**6-13. Tagging - Continued**

(3) Remove the next wire (3) from its terminated location on the terminal board and mark it with an identification tag (4).

(4) After removal and tagging of necessary wires or parts, repair, or replace faulty items as required.

c. Installing Tagged Items (fig. 6-25). Prepare to replace all wires or parts that have been removed by positioning these items as near to their original location as possible.

(1) Check tag (4 and 2) to make sure that correct wires are positioned in their proper locations.

(2) Replace one wire at a time to eliminate confusion. Remove tag (4) before attaching wire (3) to the terminal board.

(3) Secure wire (3) to terminal board E-5 at the appropriate terminal lug.

(4) Remove tag (2) before attaching wire (1) to the terminal board.

(5) Secure wire (1) to terminal board E-5 at the appropriate terminal lug.

**CHAPTER 7**  
**ELECTRONIC DATA**

---

**Section I. BASIC LAWS AND FORMULAS**

**7-1. General.**

This section defines the basic laws and formulas used in electronic theory. For clarity the section has been divided into two parts, one addressing direct current (DC) and the other addressing alternating current (AC).

**7-2. Direct Current.**

a. General. Direct current or DC is the flow of electrons from a point of low potential to a point of high potential. Typical sources of DC would be a flashlight or automobile battery.

b. Ohm's Law for DC Current. Developed by George Simon Ohm in 1827, this law states that the current flowing in a circuit is directly proportional to the applied voltage and inversely proportional to the circuit resistance. Figure 7-1 shows the three forms of this law as related to the simple DC circuit provided.

$$I = \frac{E}{R}$$

$$E = IR$$

$$R = \frac{E}{I}$$

Where: I is the current in amperes  
E is the voltage in volt  
R is the resistance in ohms.

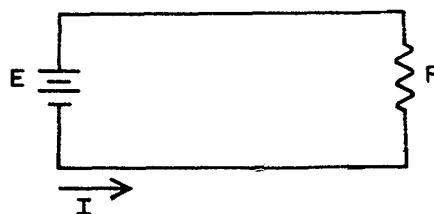

*Figure 7-1. Ohm's Law for DC Circuits*

c. DC Power. Power is a measure of the energy expended in a circuit when the current flows through a resistance. Power is measured in watts and can be determined by the following formulas:

$$P = IE$$

$$P = I^2R$$

$$P = \frac{E^2}{R}$$

Where: P is the power in watts.  
E is the voltage in volts.  
I is the current in amperes.  
R is the resistance in ohms.



7-2. Direct Current - Continued

d. DC Circuit Evaluation. The four quantities (voltage, current, resistance, and power) are the basic quantities used in evaluating a DC circuit. Table 7-1 provides a useful tool for determining the unknown values if any two of these quantities are known. Enter the table in the row indicating the known values. Find the appropriate formula(s) for the desired unknown(s) under the proper column heading.

Table 7-1. DC Relationships

Known Values	Formulas for Determining Unknown Values of			
	I	R	E	P
I & R	-	-	$E = IR$	$P = I^2R$
I & E	-	$R = \frac{E}{I}$	-	$P = IE$
I & P	-	$R = \frac{P}{I^2}$	$E = \frac{P}{I}$	-
R & E	$I = \frac{E}{R}$	-	-	$P = \frac{E^2}{R}$
R & P	$I = \sqrt{\frac{P}{R}}$	-	$E = \sqrt{PR}$	-
E & P	$I = \frac{P}{E}$	$R = \frac{E^2}{P}$	-	-

e. Resistance. Resistance is the opposition to the flow of current. The total or equivalent resistance of a circuit is dependent on how the resistors are connected. Resistors can be connected in series as shown in figure 7-2 or in parallel as shown in figure 7-3. The formulas for calculating series and parallel resistance are given below.

- (1) The equivalent resistance of a series circuit is the algebraic sum of all the resistors in the circuit. This is stated mathematically as follows:

$$R_{T1} = R + R_2 + R_3$$

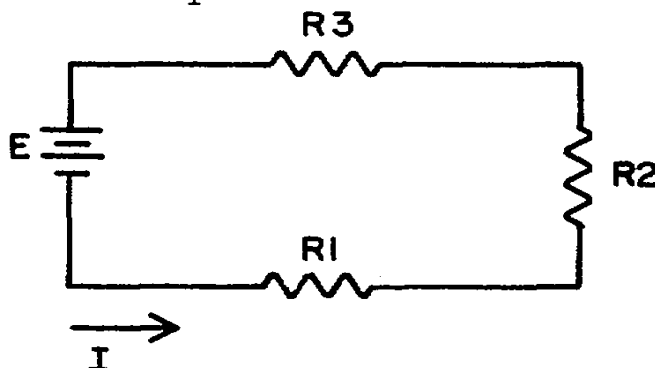

Figure 7-2. Series Circuit

## 7-2. Direct Current - Continued

- (2) The general formula for any number of unequal value resistors in parallel is:

$$R_T = \frac{1}{\frac{1}{R_1} + \frac{1}{R_2} + \frac{1}{R_3}}$$

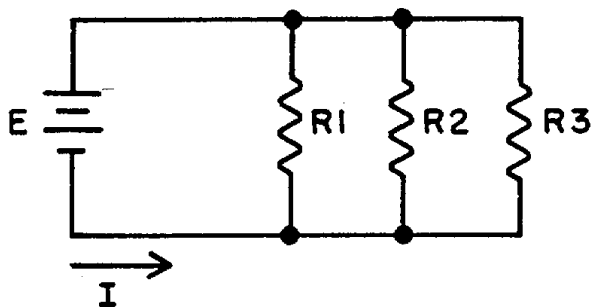

Figure 7-3. Parallel Circuit

- (3) There are several special cases regarding parallel resistances.
- (a) The first case relates to a circuit with only two unequal value resistors in parallel. In this case the equivalent resistance can be found by dividing the product of the two resistors by their sum. This is stated mathematically as follows:

$$R_T = \frac{R_1 R_2}{R_1 + R_2}$$

- (b) The second special case involves any number of equal value resistors in parallel. The equivalent resistance is found by dividing the resistance of one resistor by the number of resistors in parallel or:

$$R_T = \frac{R}{n}$$

Where:  $R_T$  is the equivalent resistance.  
 $R$  is the resistance value of each resistor.  
 $n$  is the number of resistors in parallel.

### 7-3. Alternating Current.

a. General. Alternating current or AC consists of the flow of electrons in first one direction and then in the opposite (alternate) direction in a closed circuit. Typical AC such as household current switches direction in a cyclic manner as shown by the sine wave in figure 7-4.

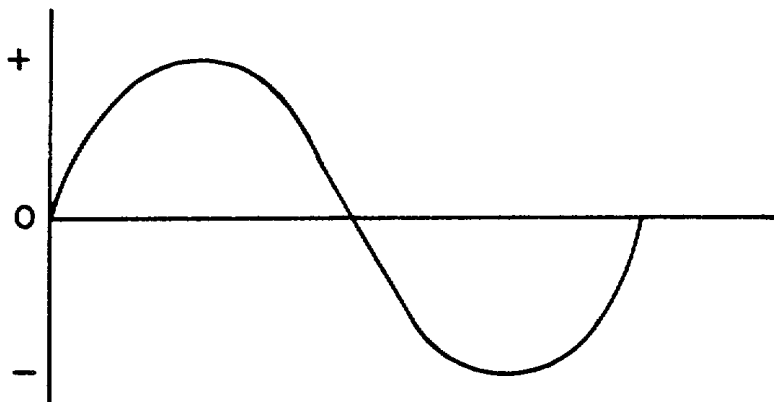

Figure 7-4. AC Sine Wave

b. Ohm's Law for AC Circuits. The difference between Ohm's Law for DC and Ohm's Law for AC is the resistance (R) has been replaced by the impedance (Z). Ohm's Law states that the current flowing in an AC circuit is directly proportional to the applied voltage and inversely proportional to the circuit impedance. Figure 7-5 shows a simple AC circuit and the various forms of Ohm's Law which apply to AC circuits.

$$I = \frac{E}{Z}$$

$$E = IZ$$

$$E = \frac{E}{I}$$

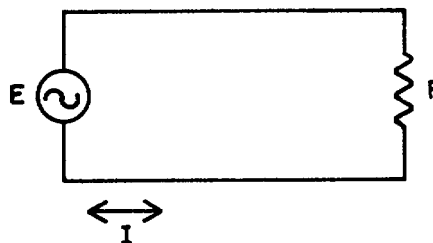

Where: E is the voltage in volts.  
I is the current in amperes.  
Z is the impedance in ohms.

Figure 7-5. Ohm's Law for AC Circuits

7-3. **Alternating Current - Continued**

c. AC Power. The power expended in an AC circuit is calculated by the formulas:

**NOTE**

The phase angle  $\theta$  is the difference in degrees that the current leads or lags the voltage in a reactive circuit. The phase angle is determined by the formula:

$$\theta = \arctan \frac{X}{R}$$

Where: X is the inductive or capacitive reactance in ohms.  
R is the resistance in ohms.

$$P = I^2 Z \cos \theta$$

$$P = IE \cos \theta$$

$$P = \frac{E^2 \cos \theta}{Z}$$

Where: P is the power in watts.  
E is the voltage in volts.  
I is the current in amperes.  
Z is the impedance in ohms.  
 $\theta$  is the phase angle in degrees.

Table 7-2 shows the basic voltage, current, and power relationships for AC circuits.

Table 7-2. AC Relationships

Known values	Formulas for determining unknown values of			
	I	R	E	P
I & Z	-	-	$E = IZ$	$P = I^2 Z \cos \theta$
I & E	-	$Z = \frac{E}{I}$	-	$P = IE \cos \theta$
I & P	-	$Z = \frac{P}{I^2 \cos \theta}$	$E = \frac{P}{I \cos \theta}$	-
Z & E	$I = \frac{E}{Z}$	-	-	$P = \frac{E^2 \cos \theta}{Z}$
Z & P	$I = \frac{P}{\sqrt{Z \cos \theta}}$	-	$E = \frac{PZ}{\sqrt{\cos \theta}}$	-
E & P	$I = \frac{P}{E \cos \theta}$	$Z = \frac{E^2 \cos \theta}{P}$	-	-

**7-3. Alternating Current - Continued**

d. Impedance. The impedance of an AC circuit is made up of two components. The first component is the pure resistance which is the same as that found in DC circuits. The second component is the reactance which is the opposition to the flow of AC by the inductive and/or capacitive components of a circuit.

(1) Capacitive Reactance. The reactance of a capacitor is calculated by the formula:

$$X_c = \frac{1}{2 \pi f c}$$

Where:  $X_c$  is the capacitive reactance in ohms.  
 $f$  is the frequency in hertz.  
 $c$  is the capacitance in farads.  
 $\pi$  is the constant 3.14159.

(2) Capacitance. The total capacitance for a circuit can be calculated using the formula in figure 7-6.

For capacitors in parallel:

$$C_T = C_1 + C_2 + C_3$$

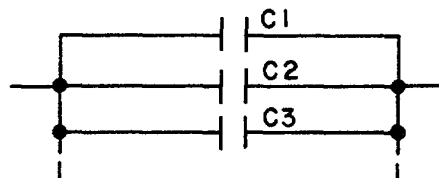

For more than two capacitors in series

$$C_T = \frac{1}{C_1 + C_2 + C_3}$$

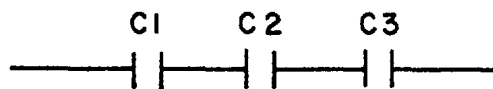

For two capacitors in series:

$$C_T = \frac{C_1 + C_2}{C_1 C_2}$$



Figure 7-6. Capacitance Formulas

7-3. Alternating Current - Continued

(3) Inductive Reactance. The reactance of an inductor is calculated by the formula:

$$X_L = 2 \pi fL$$

Where:  $X_L$  is the inductive reactance in ohms.  
 $f$  is the frequency in hertz.  
 $L$  is the inductance in henries.  
 $\pi$  is the constant 3.14159.

(4) Inductance. The total inductance for a circuit can be calculated using the formulas in figure 7-7.

For inductors in series:

$$L_T = L_1 + L_2 + L_3$$



For more than two inductors in parallel:

$$L_T = \frac{1}{\frac{1}{L_1} + \frac{1}{L_2} + \frac{1}{L_3}}$$

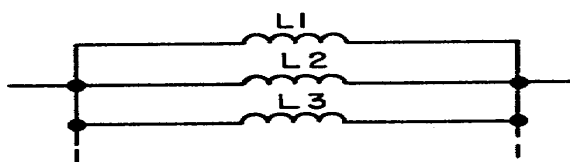

For two inductors in parallel

$$L_T = \frac{L_1 L_2}{L_1 + L_2}$$

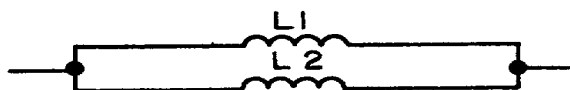

Figure 7-7. Inductance Formulas

(5) General Formula. As stated earlier the impedance of an AC circuit is the total opposition to the flow of current within the circuit. The general forms of the formulas for calculating impedance are given below:

7-3. Alternating Current - Continued

(a) For parallel circuits:

$$Z = \frac{RX}{\sqrt{R^2 + X^2}}$$

(b) For series circuits:

$$Z = \sqrt{R^2 + X^2}$$

Where: Z is the total impedance in ohms.

R is the total resistance in ohms.

X is the total reactance in ohms.

e. Instantaneous Values of AC Voltage. As the AC voltage and current pass through the sine wave cycle depicted in figure 7-8, there are several instantaneous values of interest, such as the peak, effective, and average values of the sine wave.

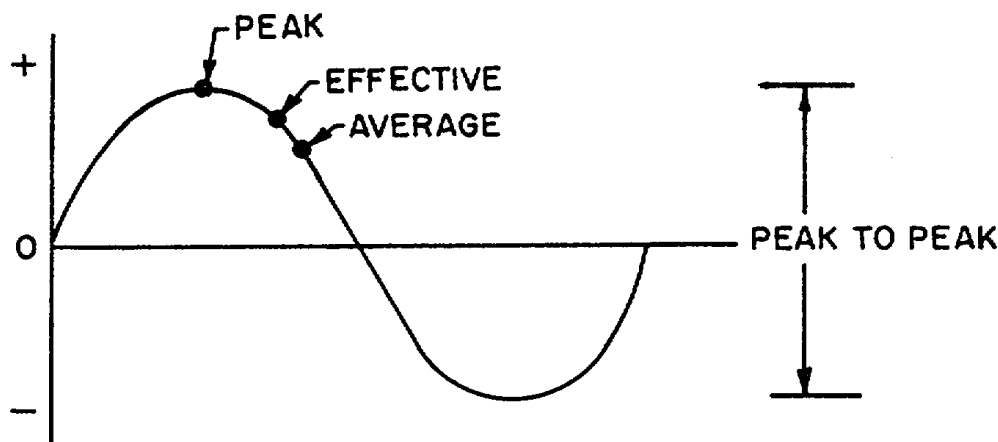

Figure 7-8. Instantaneous Values of AC

The relationships between the instantaneous values shown are provided in table 7-3. Given any one of the four values, the remaining three values can be calculated using the relationships from the table.

Table 7-3. Instantaneous Values of AC

Given Values	Multiplying factor to get			
	Average	Effective	Peak	Peak-to-Peak
Average	-	1.11	1.57	3.14
Effective	0.9	-	1.414	2.828
Peak	0.637	0.707	-	2.0
Peak-to-Peak	0.32	0.3535	0.5	-

Section II. ELECTRONIC COMPONENT IDENTIFICATION

7-4. Resistor Identification.

a. General. There are two basic types of resistors, fixed and variable. Both types may use either wire-wound or carbon composition as the resistive element. A fixed resistor has only one set value. A variable resistor is usually called a potentiometer, it's resistance can be changed to vary the amount of current in a circuit.

b. Resistance Markings. Variable resistors usually have their resistance range marked on their case. Wire-wound fixed resistors usually have the value of resistance stamped on their side. Some resistors are identified by three or four digit letter and number designators. The letter (R) is used in place of a decimal point when fractional values of an ohm are needed (for example 2R7 = 2.7 ohms.)

c. Resistor Color Codes. A color code has been developed for identification of fixed value composition and film resistors. Refer to figure 7-9 for the color codes and an explanation of the various bands.

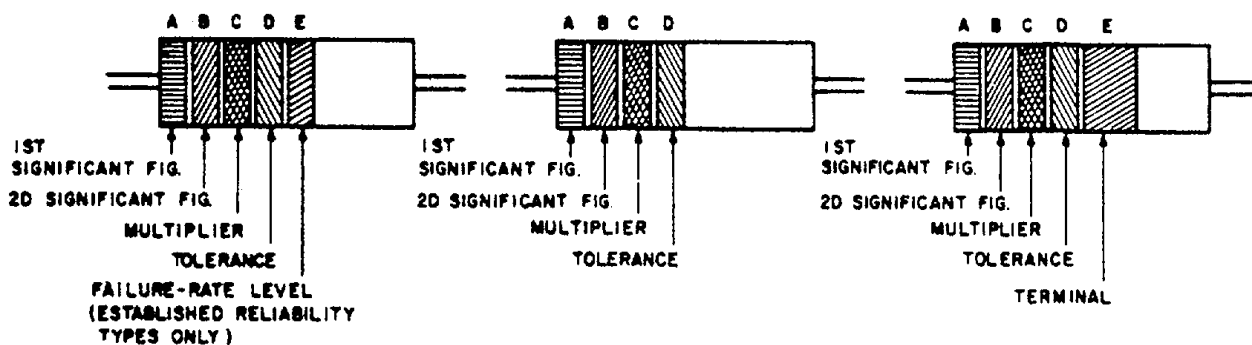

COLOR CODE MARKING FOR COMPOSITION TYPE RESISTORS.

COLOR-CODE MARKING FOR FILM-TYPE RESISTORS.

BAND A		BAND B		BAND C		BAND D		BAND E		
COLOR	FIRST SIGNIFICANT FIGURE	COLOR	SECOND SIGNIFICANT FIGURE	COLOR	MULTIPLIER	COLOR	RESISTANCE TOLERANCE (PERCENT)	COLOR	FAILURE RATE LEVEL	TERM.
BLACK.....	0	BLACK.....	0	BLACK.....	1			BROWN	M=1.0	SOLD-ERABLE
BROWN.....	1	BROWN.....	1	BROWN.....	10			RED	P=0.1	
RED.....	2	RED.....	2	RED.....	100			ORANGE	R=0.01	
ORANGE.....	3	ORANGE.....	3	ORANGE.....	1,000			YELLOW	S=0.001	
YELLOW.....	4	YELLOW.....	4	YELLOW.....	10,000	SILVER	± 10 (COMP. TYPE ONLY)	WHITE		
GREEN.....	5	GREEN.....	5	GREEN.....	100,000	GOLD	± 5			
BLUE.....	6	BLUE.....	6	BLUE.....	1,000,000	RED	± 2 (NOT APPLICABLE TO ESTABLISHED RELIABILITY).			
PURPLE..... (VIOLET)	7	PURPLE..... (VIOLET)	7							
GRAY.....	8	GRAY.....	8	SILVER..	0.01					
WHITE.....	9	WHITE.....	9	GOLD	0.1					

Figure 7-9. Color Code Markings for Military Standard Resistors



#### 7-4. Resistor Identification - Continued

d. Resistor Voltage/Wattage Rating. Another important factor in resistor selection/identification is the voltage/wattage rating of the resistor. This rating is an indication of the maximum amount of power the resistor is capable of handling. The following paragraphs explain several methods used.

- (1) On variable resistors and some fixed resistors the voltage and or wattage rating will be indicated by numbers and letters printed on the resistor.
- (2) In the case of color coded carbon composition resistors, the wattage is normally indicated by the size (length and diameter) of the resistor. The smaller the size of a resistor, the less power or voltage it can handle. Typical wattage sizes are 1/8, 1/4, 1/2, 1, and 2 watts. Figure 7-10 can be used as a quick reference in determining the wattage of this type resistor. Larger wattage resistors are typically wire-wound and they will have their wattage printed on their side.

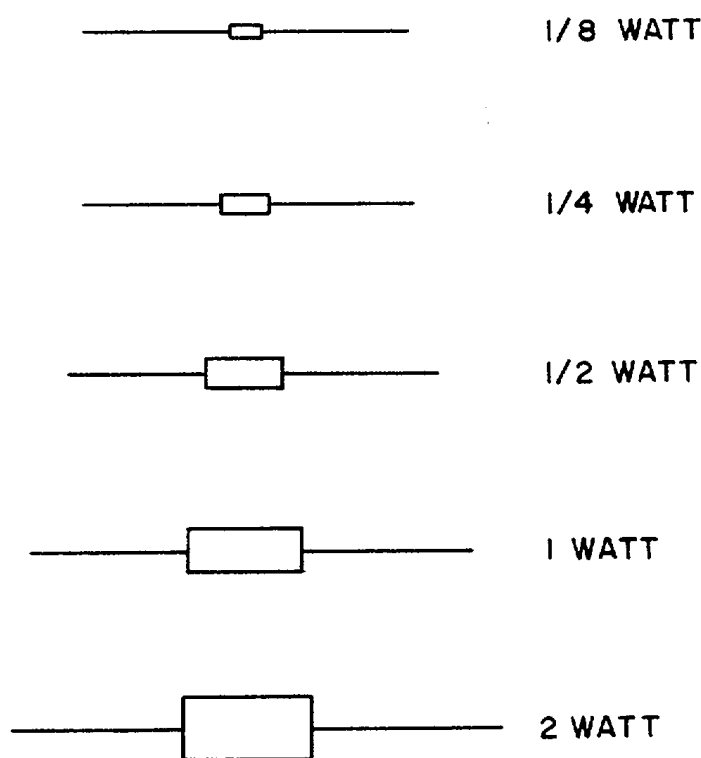
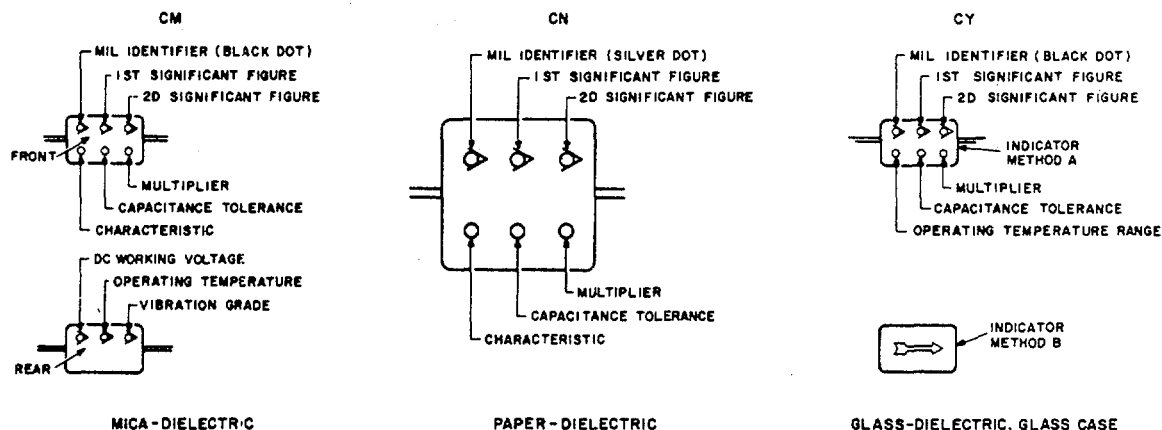

Figure 7-10. Typical Carbon Resistor Wattage Reference Chart

#### 7-5. Capacitor Identification.

As is the case with resistors there are many types and sizes of capacitors and many ways of marking them. Figure 7-11 shows many of the different types of capacitors and marking systems which may be encountered. One type of capacitor not shown in figure 7-11 is the electrolytic capacitor. This type capacitor comes in many shapes and sizes. DC electrolytic capacitors have their positive terminal marked and care must be taken to insert them into the circuit properly. The capacitance and voltage rating of this type capacitor is typically printed on the side of the capacitor.

CAPACITORS, FIXED, VARIOUS-DIELECTRICS, STYLES CM, CN, CY, AND CB



COLOR CODE MARKING FOR MILITARY STANDARD CAPACITORS

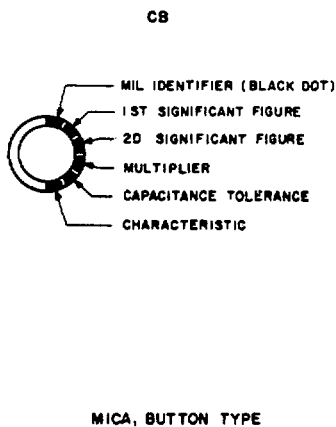

COLOR	MIL ID	1ST SIG FIG.	2D SIG FIG.	MULTIPLIER	CAPACITANCE TOLERANCE				CHARACTERISTIC			DC WORKING VOLTAGE	OPERATING TEMP RANGE	VIBRATION GRADE
					CM	CN	CY	CB	CM	CN	CB			
BLACK	CM, CY, CB	0	0	1			±20%	±20%		A		-55° TO +70°C	10-55 HZ	
BROWN		1	1	10					B	E	B			
RED		2	2	100	±2%		±2%	±2%	C			-55° TO +85°C		
ORANGE		3	3	1,000		±30%			D		D	300		
YELLOW		4	4	10,000					E			-55° TO +125°C	10-2,000HZ	
GREEN		5	5		±5%				F			500		
BLUE		6	6									-55° TO +150°C		
PURPLE (VIOLET)		7	7											
GREY		8	8											
WHITE		9	9											
GOLD				0.1			±5%	±5%						
SILVER	CN				±10%	±10%	±10%	±10%						

Figure 7-11. Capacitor Identification (Sheet 1 of 2)

**CAPACITORS TEMPERATURE COMPENSATING STYLE CC**

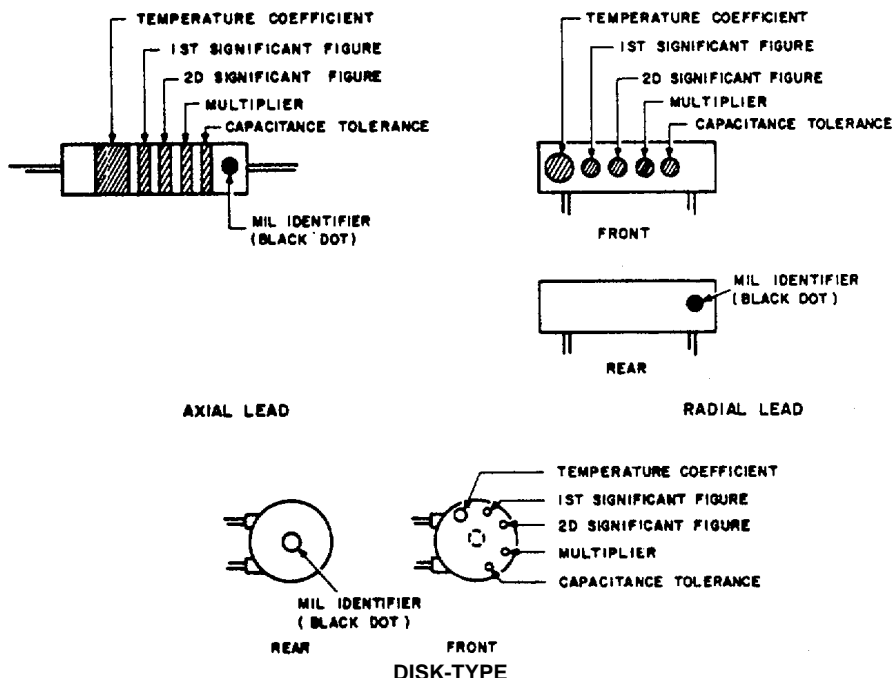

**COLOR CODE MARKING FOR MILITARY STANDARD CAPACITORS**

COLOR	TEMPERATURE COEFFICIENT <sup>4</sup>	1ST SIG FIG.	2D SIG FIG.	MULTIPLIER <sup>1</sup>	CAPACITANCE TOLERANCE		MIL ID
					CAPACITANCES OVER 10 UUF	CAPACITANCES 10 UUF OR LESS	
BLACK	0	0	0	1		± 2.0 UUF	CC
BROWN	-30	1	1	10	± 1%		
RED	-80	2	2	100	± 2%	± 0.25 UUF	
ORANGE	-150	3	3	1,000			
YELLOW	-220	4	4				
GREEN	-330	5	5		± 5%	± 0.5 UUF	
BLUE	-470	6	6				
PURPLE (VIOLET)	-750	7	7				
GREY		8	8	0.01			
WHITE		9	9	0.1	± 10%		
GOLD	+100					± 1.0 UUF	
SILVER							

1. THE MULTIPLIER IS THE NUMBER BY WHICH THE TWO SIGNIFICANT (SIG) FIGURES ARE MULTIPLIED TO OBTAIN THE CAPACITANCE ON UUF.
2. LETTERS INDICATE THE CHARACTERISTICS DESIGNATED IN APPLICABLE SPECIFICATIONS: MIL-C-5, MIL-C-25D, MIL-C-11272B, MIL-C-10950C RESPECTIVELY.
3. LETTERS INDICATE THE TEMPERATURE RANGE AND VOLTAGE-TEMPERATURE LIMITS DESIGNATED IN MIL-C-11015D.
4. TEMPERATURE COEFFICIENT IN PARTS PER MILLION PER DEGREE CENTIGRADE.

Figure 7-11. Capacitor Identification (Sheet 2 of 2)

7-6 Inductor Identification.

Although not used as much as resistors and capacitors, inductors are used generally in tuning sections of electronic circuits. Inductors may be fixed or variable as is the case with resistors and capacitors. Figure 7-12 provides several examples and indicates the color code used for marking radio frequency (rf) inductors. Variable inductors will usually have the size and voltage ratings marked on the side of the inductor.

**COLOR CODE MARKING FOR MILITARY STANDARD INDUCTORS**

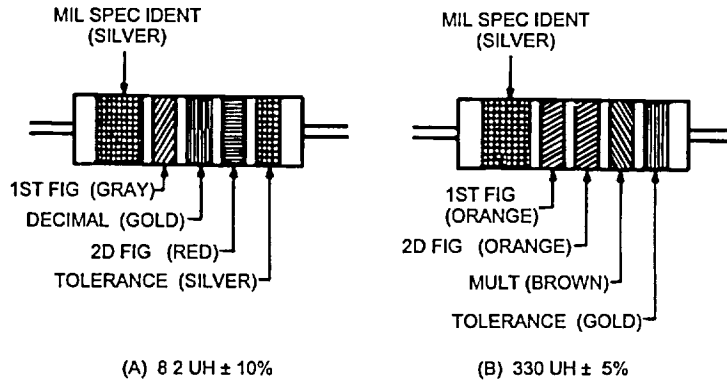

COLOR CODING FOR TABULAR ENCAPSULATED R F. CHOKES AT A, AN EXAMPLE OF THE CODING FOR AN 8 2 UH CHOKE IS GIVEN AT B. THE COLOR BANDS FOR A 330 UH INDUCTOR ARE ILLUSTRATED

COLOR CODING FOR TABULAR ENCAPSULATED R F CHOKES

COLOR	SIGNIFICANT FIGURE	MULTIPLIER	INDUCTANCE TOLERANCE (PERCENT)
BLACK	0	1	1
BROWN	1	10	2
RED	2	100	3
ORANGE	3	1,000	
YELLOW	4		
GREEN	5		
BLUE	6		
VIOLET	7		
GRAY	8		
WHITE	9		
NONE			20
SILVER			10
GOLD	DECIMAL POINT		5

MULTIPLIER IS THE FACTOR BY WHICH THE TWO COLOR FIGURES ARE MULTIPLIED TO OBTAIN THE INDUCTANCE VALUE OF THE CHOKE COIL

Figure 7-12. RF Inductor Identification

7-7. Semiconductor Identification

a. Diodes. Diodes also are found in many shapes and sizes. They perform a wide variety of functions within a circuit such as rectifying an AC voltage or waveform shaping. Diodes are typically marked with a number consisting of IN followed by a series of numbers. The IN identifies the part as a diode and the following numbers identify the particular type of diode. Figure 7-13 shows some of the typical sizes and shapes in which diodes are found. This figure provides an aid in identifying the positive (anode) and negative (cathode) terminals of the diode as related to the schematic symbol for a diode which is shown in figure 7-14. Diodes and other electronic components must be installed with the correct polarity to function properly. If the polarity is reversed, the diode as well as the rest of the associated components and circuit could be damaged. The polarity of a semiconductor is usually shown by colored dots, bands, caps, letters, or symbols, and positive (+) or negative (-) signs.

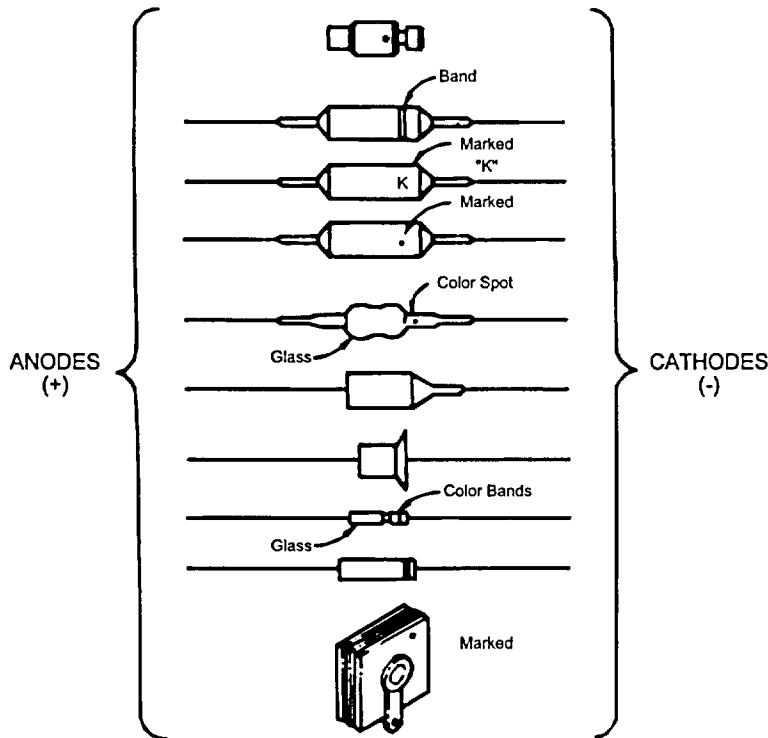

Figure 7-13. Typical Diode Shapes and Markings

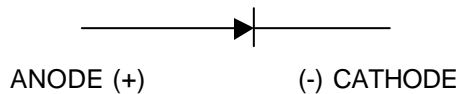

Figure 7-14. Diode Schematic Symbol

7-7. Semiconductor Identification - Continued

a. Transistors. Transistors are now found in almost every type of electronic circuit. Although they come in many sizes and serve many functions, the two most common types encountered are the N-P-N and the P-N-P. The schematic diagrams for these transistors are found in figure 7-15. Standard convention is for the arrow in the schematic to point toward the N type material.

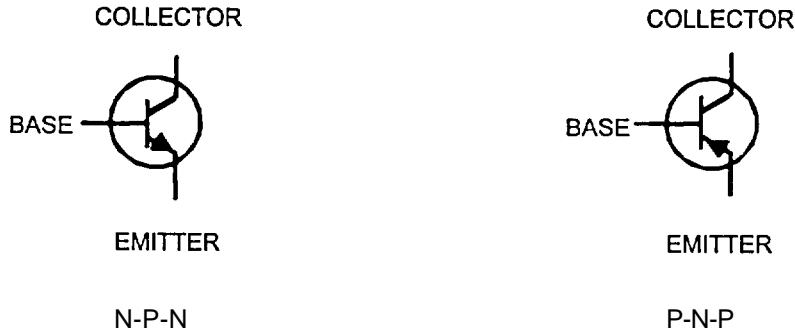

Figure 7-15. N-P-N and P-N-P Transistors

- (1) Transistors are marked with a 2N which identifies the part as a transistor followed by a series of numbers which identify the type of transistor. This number is found on the top or side of the transistor package. Transistors are packaged in a wide variety of different containers. The most common packaging encountered is the three lead, can-like package shown in figure 7-16.

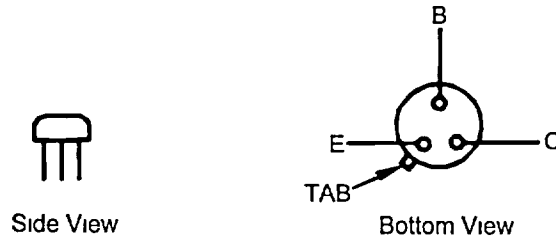

Figure 7-16. Transistor Packaging

- (1) Typically the emitter (E) is the lead closest to the tab on the transistor as shown in figure 7-16. The base (B) and collector (C) are found by going clockwise from the emitter while looking at the bottom of the transistor.

**NOTE**

**These are typical connections most commonly found. A transistor data book which provides drawings of connection layout should be used to verify the proper connections for a specific type of transistor.**

a. Dual-In-Line Packages (DIPs). These components are rectangular, integrated circuit components with leads usually mounted through the board. Dimensions and numbers of leads vary. Index or orientation markings appear in the center of one short side of the component body, while lead numbers appear on top of the component and are read in a counterclockwise direction.

7-7. Semiconductor Identification - Continued

a Flat Pack. Flat Pack integrated circuit packages commonly contain 8,10,12,14, or more leads. Standard center-to-center lead spacing is 0.050 inch. Unlike DIPs or TO Cans, most flat packs are not mounted through the board, but are planar mounted to form lap solder joints. The index point may appear on the corner of the first lead or centered between the number 1 lead and the top of the component. The leads are numbered counterclockwise from the index point.

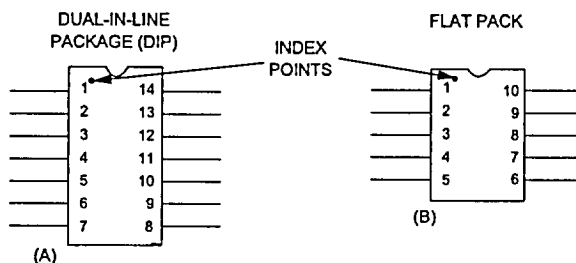

Figure 7-16.1. Component Installation

7-8. Military Fuse Identification.

Tables 7-4 thru 7-7 provide various information used in identifying fuses. Figure 7-17 provides an example of a fuse marking using these tables.

Table 7-4. Fuse Style

Code	Material*	Size (in.)	Code	Material	Size (in)
F01	A	1/4 x 1	F21	C	2.406 x 8-5/8
F02	A	1/4 x 1-1/4	F22	C	2.906 x 10-3/8
F03	B	1/4 x 1-1/4	F27	C	13/32 x 3
F04	A	1/4 x 1-1/4	F28	C	13/32 x 4-1/2
F05	A	9/32 x 1-1/4	F29	C	.812 x 5
F06	B	9/32 x 1-1/4	F30	C	.812 x 10
F07	A	13/32 x 1-1/2	F60	D	13/32 x 1-1/2
F09	C	13/32 x 1-1/2	F61	D	.562 x 2
F10	C	13/32 x 1-1/2	F62	D	.812 x 3
F11	B	13/32 x 1-1/2	F63	D	1.312 x 5-7/8
F15	C	9/16 x 2	F64	D	1.875 x 7-1/8
F16	C	.812 x 3	F65	D	2.405 x 8-5/8
F19	C	1.312 x 5-7/8	F66	D	2.906 x 10-3/8
F20	C	1.875 x 7-1/8	F67	D	2.000 x 10-3/8

- \*A Glass
- B Plastic or Ceramic
- C Fiber
- D Glass Melamine

Table 7-5. Fuse Voltage Ratings

Code	Voltage	Code	Voltage
A	31	H	500
B	52	J	1000
C	90	L	2500
D	125	N	5000
G	250	P	10000

7-8. Military Fuse Identification - Continued

Table 7-6. Fuse Current Ratings

Code*	Capacity in Amps
R001 to R009	.001 to .009
R010 to R099	.010 to .099
R100 to R999	.100 to .999
1R00 to 9R99	1.00 to 9.99
10R0 to 99R9	10.0 to 99.9
100R to 999R	100. to 999.

\* R denotes decimal point

Table 7-7. Fuse Characteristics

Code	Characteristics
A	Normal interrupting capacity
B	Time lag (Slow blow)
C	Very high interrupting capacity

Example of marking for a glass, 1/4 X 1-1/4 inch, 250 - volt, 1.5 ampere, normal-interrupting capacity fuse.

Example for 1/4 X 1-1/4 inch, 250-volt, 1.5-ampere, normal-interrupting capacity fuse.

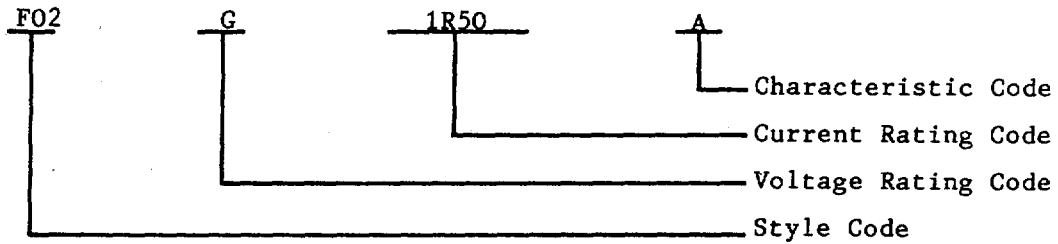

Figure 7-17. Fuse Marking Example



Section III. SCHEMATIC DIAGRAM SYMBOLS

7-9. Electronic Component Schematic Symbols.

There are many symbols which may be encountered on a schematic diagram of an electronic circuit. Figure 7-18 shows many of the most commonly used symbols. This is not a complete list and other variations for some of these symbols may be encountered. ANSI Y32.2, Graphic Symbols for Electrical and Electronic Diagrams provides a complete references for approved military electronic symbols.

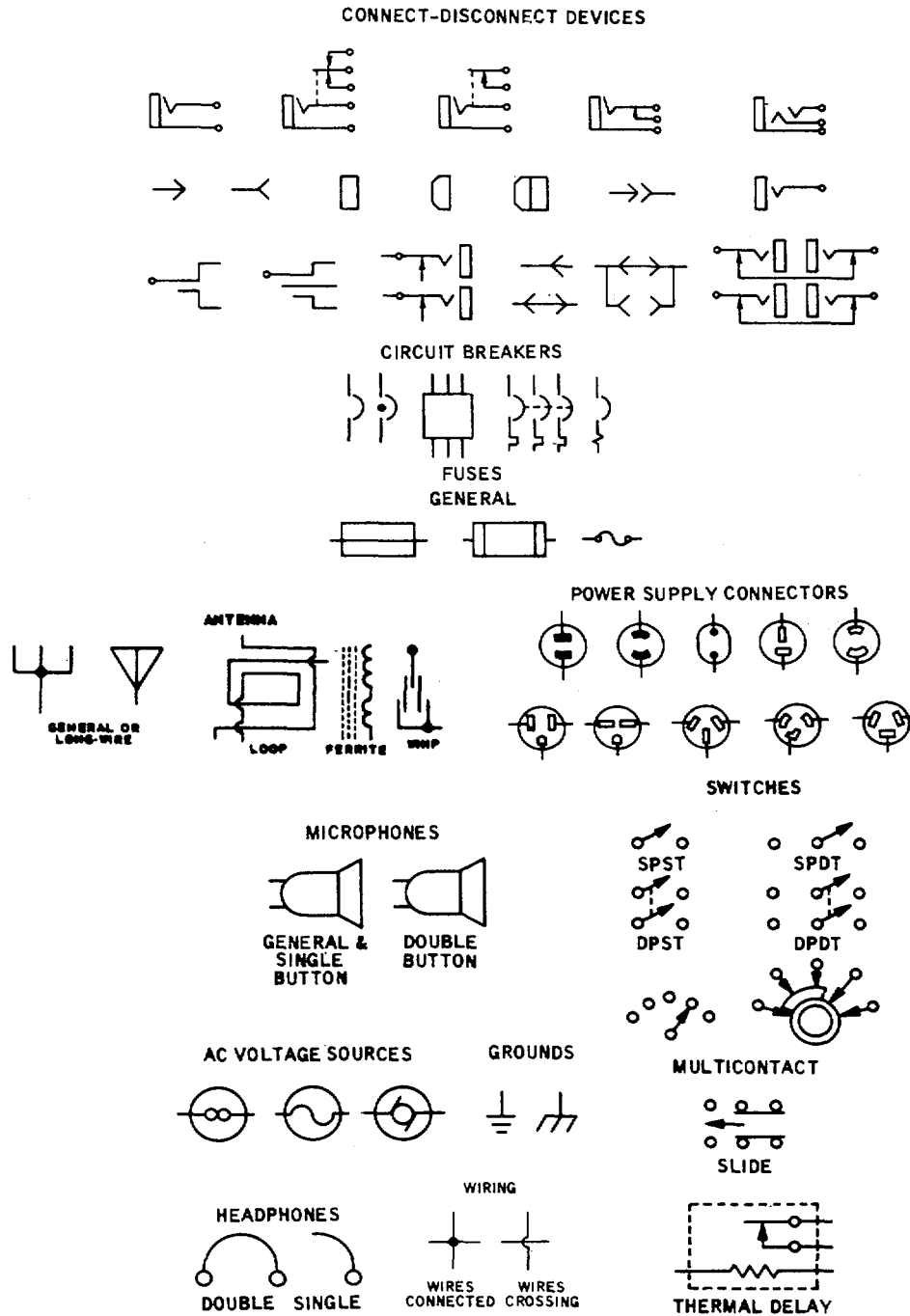

Figure 7-18. Electronic Component Schematic Symbols (Sheet 1 of 3)

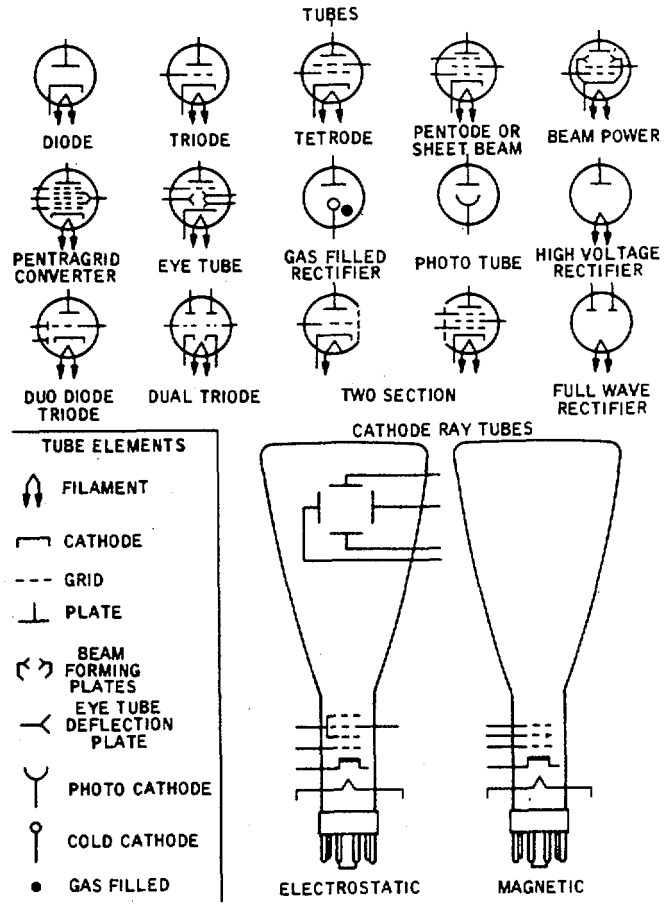

Figure 7-18. Electronic Component Schematic Symbols (Sheet 2 of 3)

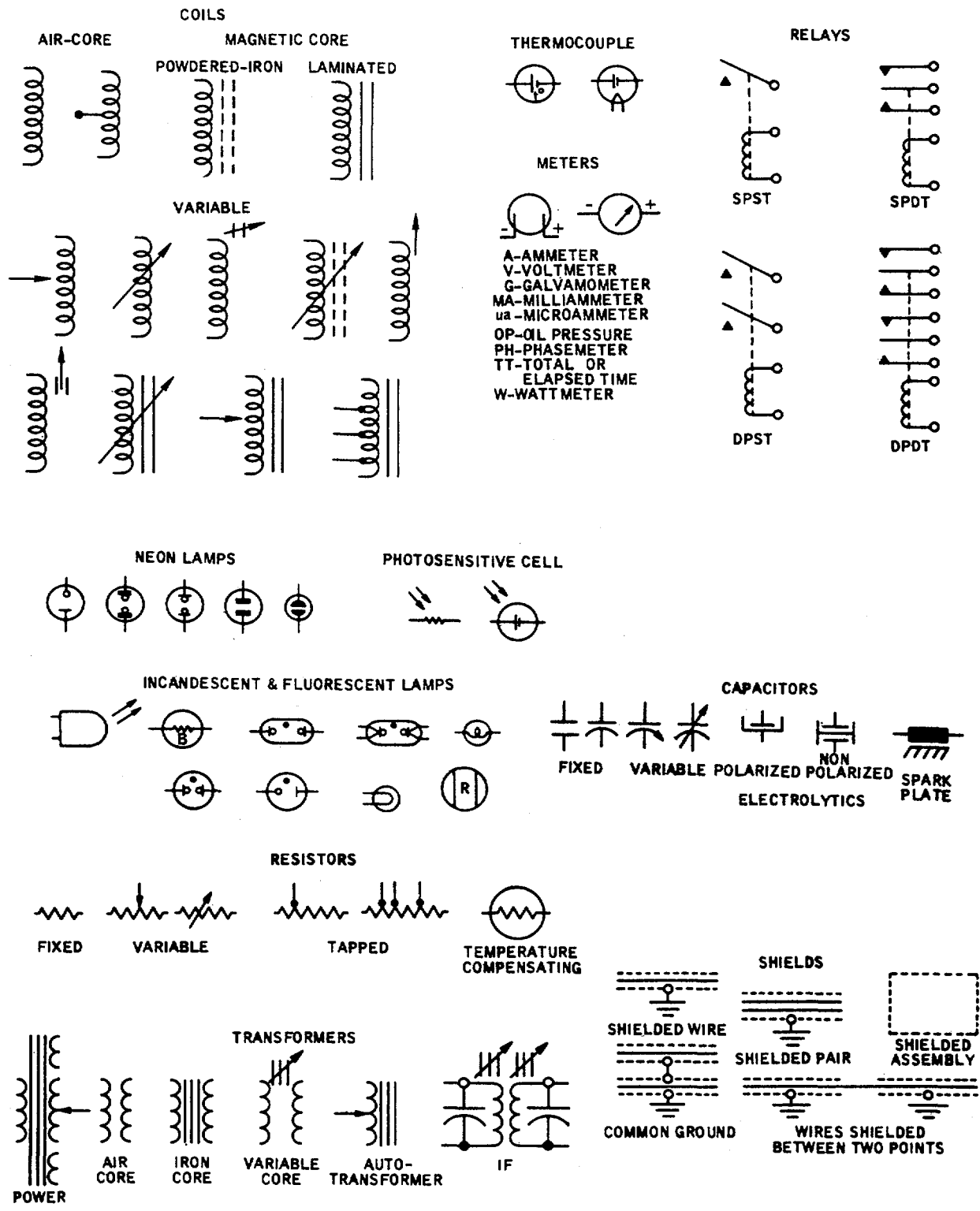
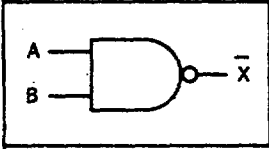
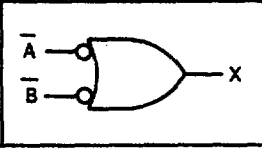
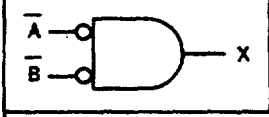
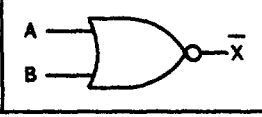
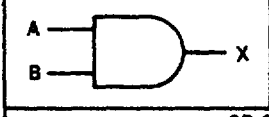
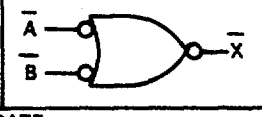
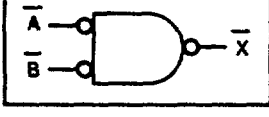
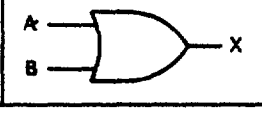

Figure 7-18. Electronic Component Schematic Symbols (Sheet 3 of 3)

**7-10. Logic Component Schematic Symbols.**

a. Many systems will contain some amount of digital or logic circuitry. Special logic symbols are used along with truth tables which describe the logic function performed. Figure 7-19 shows the basic logic gate symbols and their corresponding truth table. MIL-STD-806 provides a complete reference for approved military logic symbols.

**GATE SYMBOLS REPRESENT A SPECIFIC TYPE OF HARDWARE DESCRIBED BY THE FOLLOWING TRUTH TABLE.**

NAND GATE		TRUTH TABLE															
		<table border="1"> <thead> <tr> <th>A</th> <th>B</th> <th>X</th> </tr> </thead> <tbody> <tr> <td>H</td> <td>H</td> <td>L</td> </tr> <tr> <td>H</td> <td>L</td> <td>H</td> </tr> <tr> <td>L</td> <td>H</td> <td>H</td> </tr> <tr> <td>L</td> <td>L</td> <td>H</td> </tr> </tbody> </table>	A	B	X	H	H	L	H	L	H	L	H	H	L	L	H
A	B	X															
H	H	L															
H	L	H															
L	H	H															
L	L	H															
NOR GATE																	
		<table border="1"> <thead> <tr> <th>A</th> <th>B</th> <th>X</th> </tr> </thead> <tbody> <tr> <td>H</td> <td>H</td> <td>L</td> </tr> <tr> <td>H</td> <td>L</td> <td>L</td> </tr> <tr> <td>L</td> <td>H</td> <td>L</td> </tr> <tr> <td>L</td> <td>L</td> <td>H</td> </tr> </tbody> </table>	A	B	X	H	H	L	H	L	L	L	H	L	L	L	H
A	B	X															
H	H	L															
H	L	L															
L	H	L															
L	L	H															
AND GATE																	
		<table border="1"> <thead> <tr> <th>A</th> <th>B</th> <th>X</th> </tr> </thead> <tbody> <tr> <td>H</td> <td>H</td> <td>H</td> </tr> <tr> <td>H</td> <td>L</td> <td>L</td> </tr> <tr> <td>L</td> <td>H</td> <td>L</td> </tr> <tr> <td>L</td> <td>L</td> <td>L</td> </tr> </tbody> </table>	A	B	X	H	H	H	H	L	L	L	H	L	L	L	L
A	B	X															
H	H	H															
H	L	L															
L	H	L															
L	L	L															
OR GATE																	
		<table border="1"> <thead> <tr> <th>A</th> <th>B</th> <th>X</th> </tr> </thead> <tbody> <tr> <td>H</td> <td>H</td> <td>H</td> </tr> <tr> <td>H</td> <td>L</td> <td>H</td> </tr> <tr> <td>L</td> <td>H</td> <td>H</td> </tr> <tr> <td>L</td> <td>L</td> <td>L</td> </tr> </tbody> </table>	A	B	X	H	H	H	H	L	H	L	H	H	L	L	L
A	B	X															
H	H	H															
H	L	H															
L	H	H															
L	L	L															

EXCLUSIVE OR GATE		TRUTH TABLE															
		<table border="1"> <thead> <tr> <th>A</th> <th>B</th> <th>X</th> </tr> </thead> <tbody> <tr> <td>H</td> <td>H</td> <td>L</td> </tr> <tr> <td>H</td> <td>L</td> <td>H</td> </tr> <tr> <td>L</td> <td>H</td> <td>H</td> </tr> <tr> <td>L</td> <td>L</td> <td>L</td> </tr> </tbody> </table>	A	B	X	H	H	L	H	L	H	L	H	H	L	L	L
A	B	X															
H	H	L															
H	L	H															
L	H	H															
L	L	L															

Figure 7-19. Logic Gate Symbols

b. The logic gates shown in figure 7-19 have only two inputs. In reality these gates may have many inputs dependent on the loading capacity of the device. Logic gates are normally packaged together in an integrated circuit (IC) package. These IC's come in various shapes and sizes. An IC data book will provide the appropriate circuit schematic and specification for the device.

## Section IV. TROUBLESHOOTING TECHNIQUES

### 7-11. Basic Troubleshooting Procedure.

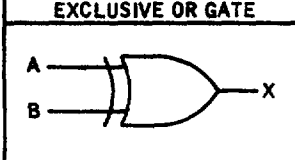
a. Trouble Symptom. The basic troubleshooting procedure is an organized plan of action to help you repair faulty electronic equipment rapidly and reliably. This systematic and logical troubleshooting procedure starts with the trouble symptom. The trouble symptom lets you know that something is wrong with the equipment. So, you have to analyze the trouble symptom as it affects the operation of the equipment. The trouble symptom provides clues that show you where to look for the trouble.

b. Sectionalize. Once you have recognized the trouble symptom, the next step is to sectionalize the trouble. Each piece of equipment is divided into a few basic sections. But to trace the trouble to a particular section, you must first analyze and evaluate the trouble symptom to decide which section is giving trouble.

c. Localize. After you have found which section of the equipment is at fault, the next step is to localize the trouble to a particular circuit or stage.

d. Isolate. After localizing, the next step is to isolate the faulty component either by making a visual inspection or by taking voltage and resistance measurements. In this manner, you pinpoint the trouble to a bad component in a single stage.

e. Repair. Correct the trouble by repairing or replacing components in the stage.

f. Check Operation. After repairing the trouble, check the operation of the equipment to make sure that it is functioning properly.

### 7-12. Troubleshooting with the Technical Manual.

a. General. This section explains how to use the technical manual (TM) when troubleshooting and performing the various procedures listed in the manual.

b. Selecting the Proper TM. The Direct Support and General Support Maintenance Manual, TM 9-1240-XXX-34 series, should be selected when performing troubleshooting procedures. This manual is divided into two volumes for this purpose.

(1) Volume I, contains troubleshooting procedures.

(2) Volume II, contains maintenance procedures.

c. How to Troubleshoot (fig. 7-20). The following steps explain how to troubleshoot using the TM 9-1240-XXX-34 series TM.

(1) Do a visual check and list any faults on DA Form 2404 before making repairs. See Volume II, Chapter 3 for what to check for.

(2) If you see any faults that may affect the checkout procedure, fix them now. This does not mean small things like painting scratches.

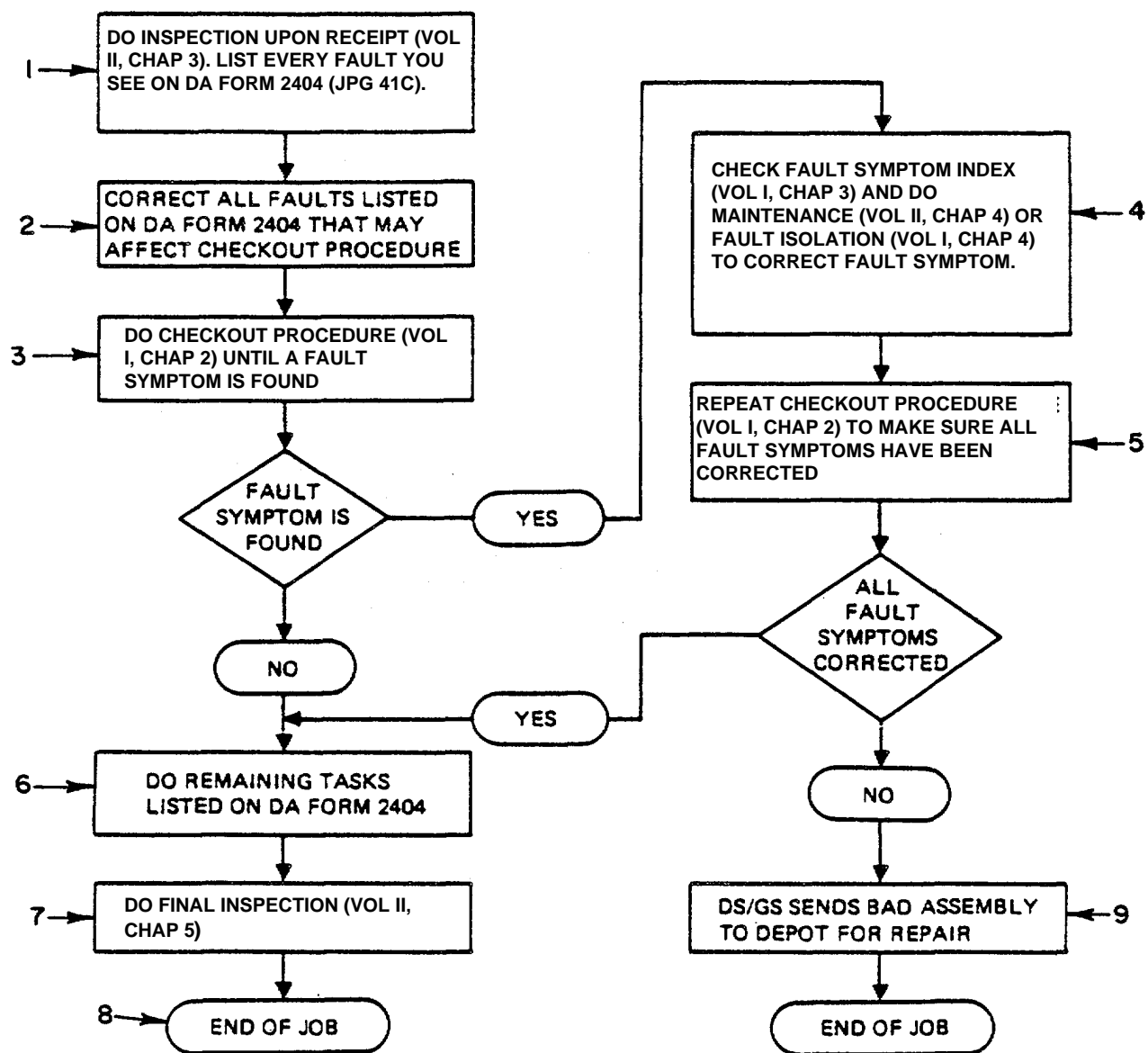

Figure 7-20. How to Troubleshoot - Diagram

### 7-12. Troubleshooting with the Technical Manual - Continued

- (3) Do the checkout procedure in Volume I, Chapter 2 from the beginning until you find a fault symptom.
- (4) When a fault symptom is found, go to the chapter noted and follow the maintenance procedure given there. If you already know the fault symptom, look at the fault symptom index in Chapter 3 of this volume.
- (5) After the bad part has been repaired or replaced, do the checkout procedure in Chapter 2 again. This is to make sure all fault symptoms have been corrected.
- (6) If all the faults are now corrected, do the remaining maintenance tasks on DA Form 2404.
- (7) Do the final inspection given in Volume II, Chapter 5.
- (8) The job is over and the good assembly is sent back to service.
- (9) If all faults were not corrected after step 5, the bad assembly is sent to the depot for repair.

### 7-13. Half-Split Method of Troubleshooting.

Half-splitting is a technique used in trouble shooting which reduces the average number of measurements needed to isolate the faulty stage or component. Consider the eight stage path shown in figure 7-21 and the technique explained in the following paragraphs

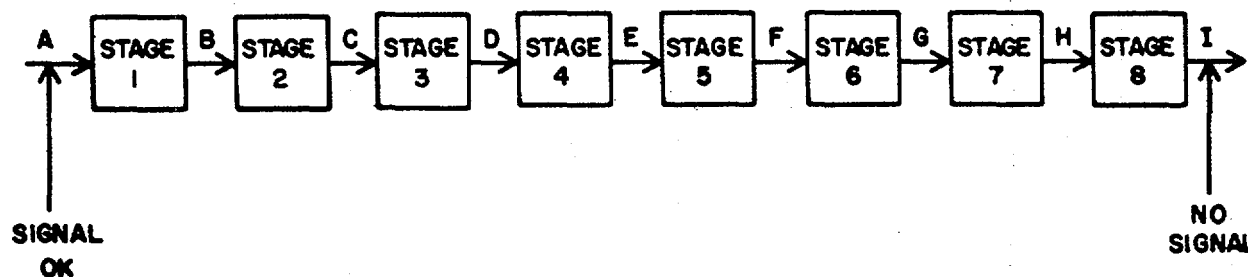

Figure 7-21. Eight Stage Block Diagram

- (1) The first measurement using half-splitting would be made at point E (the middle of the faulty path). If the signal is okay at point E the path to the left of point E is good and the problem lies between points E and I. Thus one measurement has reduced the size of the faulty path by one-half (half-splitting).
- (2) The next measurement would be made at point G again splitting the faulty path in half. If the measurement at point G is bad (no signal) the next measurement would be made at point F. This method of splitting a faulty path in half is continued until the faulty stage is isolated.

**7-13. Half-Split Method of Troubleshooting - Continued**

- (3) The time saved by using the method of half-splitting depends on the length of the faulty path and the location of the fault within the path. On the average this method is almost twice as fast (requires 1/2 the measurements) as the serial method of tracing the signal from A to I for the 8-stage circuit example. The savings are even greater for circuits with more stages.

**7-25/(7-26 blank)**



## CHAPTER 8

## ELECTRONIC TEST EQUIPMENT

## Section I. METER CHARACTERISTICS

## 8-1. Types of Meters.

a. **Multimeter.** The multimeter is a combination of a voltmeter, ohmmeter, and ammeter combined in one unit using only one meter movement. Each multimeter consists of a basic direct current (DC) meter movement combined with additional devices to serve a specific purpose. Shunt resistors are used for the ammeter, multiplier resistors for the voltmeter, and resistors and batteries for the ohmmeter. By proper arrangement of these devices along with switches and jacks (plug-in connections) the multimeter can be built into a small, compact, portable unit. However, multimeters have two distinct disadvantages over other types of meters.

- (1) **Circuit loading effect.** The input impedance of a nonsolid state multimeter is considered low as compared to the solid state multimeter. This is due to the shunt resistors and multiplier resistors used in the meters internal circuitry. When the multimeter is placed into the test circuit, the low input impedance alters the test circuit impedance. The change in the test circuit impedance will cause the measurements to be incorrect.
- (2) **Accuracy.** An analog type meter movement is used in most multimeters as the indicating device. This type of meter movement uses test circuit current to cause the pointer of the meter to move and register a reading on the scale. Operator error can be induced into the meter indication if care is not taken to observe the pointer from a straight forward position.

b. **Transistorized Voltmeter.** The transistorized voltmeter (TRVM) is also a combination of a voltmeter, ohmmeter, and ammeter contained in one unit. The transistorized voltmeter has two major advantages compared to a multimeter.

- (1) **Circuit loading effect.** The TRVM contains four transistors arranged to form an input amplifier referred to as a differential amplifier. This type of input amplifier gives the TRVM a high input impedance compared to that of a multimeter. When placed into the test circuit, the high input impedance of the TRVM has little effect on the test circuit impedance thus providing a more accurate reading.
- (2) **Accuracy.** Unlike the multimeter, the TRVM contains a power supply to supply current for operating the internal meter circuitry and meter movement. However, the same analog type meter movement, that is used in the multimeter, is also used in the TRVM. Operator error can be induced into the meter indication if care is not taken to observe the pointer position from a straight forward position.

## 8-1. Types of Meters - Continued

c. Digital Multimeter. The digital multimeter performs the same basic functions as the multimeter and the TRVM. The major difference is that the digital multimeter uses all electronic components and the measured quantity is displayed as individual numbers or digits. This accounts for a faster operation than that of the multimeter and TRVM and a more accurate indication since the quantity is displayed in numerical form.

- (1) Circuit loading effects. Like the TRVM, the digital multimeter contains input amplifier circuits which gives the meter a high input impedance. The high input impedance draws less test circuit current which reduces the effect of circuit loading. Most digital multimeters are also protected against high input voltages which might be accidentally applied to the input terminals during normal use.
- (2) Accuracy. Greater measurement accuracy is obtained when using a digital display which eliminates the need to interpret a meter indication. The measured quantity is expressed in direct numerical form.

## 8-2. Meter Usage.

a. General. Meters are designed for a variety of uses such as the wattmeter for measuring power or the field strength meter used to measure the strength of transmitted radio signals. However, this section will deal only with the three most commonly used meters, the voltage meter, the current meter, and the ohmmeter.

- (1) Voltage measurements (fig. 8-1). When attempting to measure a voltage, the operator should always remember that a voltmeter is connected in parallel to the voltage source being measured. This is necessary because the voltmeter has a very high internal resistance. If the voltmeter were connected in series, the circuit would become inoperative. Prior to connecting a voltmeter, the operator should determine a few basic facts about the circuit.
  - (a) If the voltage to be measured is DC voltage, the polarity must be determined before the connection is made. This is necessary since most meter movements operate on a direct current basis and applying a reverse polarity voltage to the meter could damage the meter movement.
  - (b) If quantity of the voltage to be measured is unknown, always select the highest voltage range available on the meter. If the selected range does not give an adequate indication, reduce the range setting one range at a time until an on scale indication is obtained.
  - (c) When making an AC voltage measurement, disregard the polarity since this type of voltage has no definite polarity. However, most voltage meters measure AC voltage in terms of the root-mean-square (RMS) value. Thus all AC voltage measurements will be the RMS value of the sine wave.

## 8-2. Meter Usage - Continued

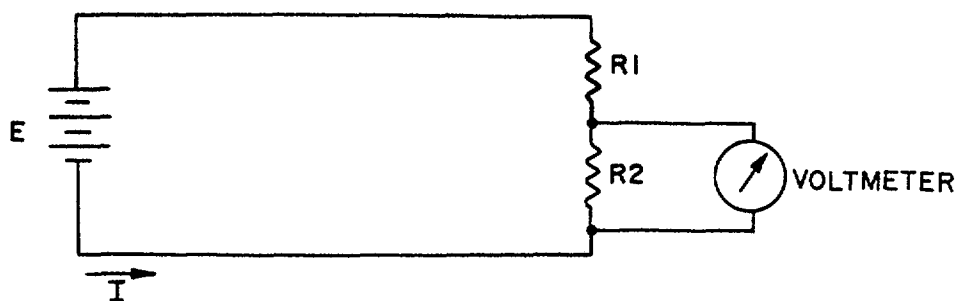

Figure 8-1. Proper Voltmeter Connection

- (2) Current measurements (fig. 8-2). When making a current measurement, always connect the current meter in series with the circuit to be measured. This is necessary because of the fact that all of the circuit current must pass through a current meter in order to establish the current value in the circuit. Prior to connecting a current meter, the operator should determine a few basic facts about the circuit.
- (a) Determine if the circuit current to be measured is DC or AC current. Use only DC current meters in DC circuits. Use only AC current meters in AC circuits.
  - (b) When using DC current meters, observe circuit polarity when connecting the meter in series with the circuit.
  - (c) If the quantity of the current to be measured is unknown, always select the highest current range available on the meter. If the selected range does not give an adequate indication, reduce the range setting one range at a time until an on scale indication is obtained.

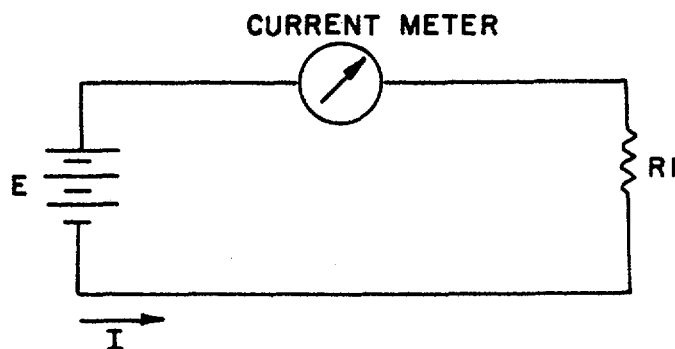

Figure 8-2. Proper Current Meter Connection

- (3) Resistance measurements (fig. 8-3). The ohmmeter is used to measure the amount of resistance in a circuit or in a circuit component itself. Before using the ohmmeter, the operator should become familiar with a few basic rules.
- (a) Always disconnect the source of power from the circuit before attempting a resistance measurement.

## 8-2. Meter Usage - Continued

- (b) Before attempting to make a resistance measurement, touch the ends of the leads together and zero adjust the ohmmeter.
- (c) If it becomes necessary to change the range setting of the ohmmeter, always zero adjust the meter before proceeding with the measurement.

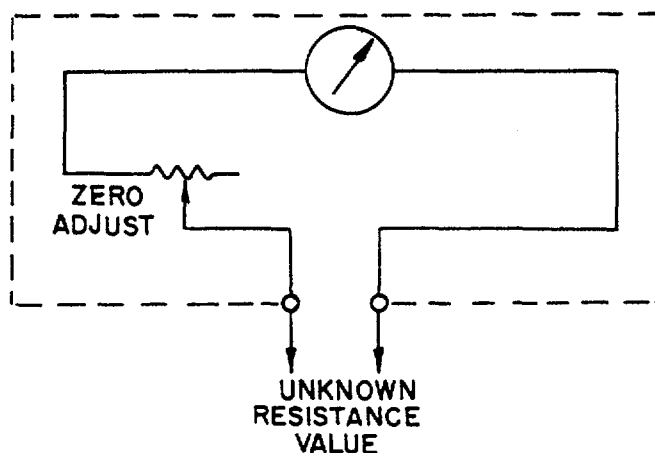

Figure 8-3. Proper Ohmmeter Connection

f. Transistor Test Technique with an Ohmmeter. The ohmmeter can do more than check for shorted or open circuit conditions. It can also be used to check the operating condition of transistors. Since the ohmmeter function of a multimeter has the same basic function as a transistor tester, the ohmmeter can be a valuable piece of test equipment when it is used to check transistor characteristics.

(1) Test requirements.

- (a) Before the instrument's test leads are connected across a transistor, a few characteristics of the ohmmeter must be understood. Its internal test potential may be anywhere from 1.5 volts to beyond 6 volts. The higher potential, if used, is likely to be involved only on the highest resistance ranges. Some transistors may be damaged when potentials in excess of 6 volts are applied. To avoid damage due to excessive current, we would also want some current-limiting resistance in series with the ohmmeter's test voltage. An inspection of the ohmmeter circuit will indicate which resistance ranges may be used and which to avoid. In general, avoiding the highest resistance ranges (possibly excessive voltage) and the lowest (possibly excessive current) will be sufficient precaution. The R x 10 or R x 100 scales may be considered safe.
- (b) Polarity of the internal battery must also be considered. In most instruments, the ground or common lead (black) goes to the negative side of the battery, with the hot or red lead going to the positive side. If this situation is reversed, the user must be aware of the fact. In all tests to be discussed, references to a positive lead or connection, or to a negative lead or connection, are always related to the polarity of the battery rather than the identification of the lead, where these two factors do not agree with each other.

## 8-2. Meter Usage - Continued

- (2) The two-diode concept.
  - (a) It is common knowledge that a semiconductor diode can be checked by measuring its forward and reverse resistances and comparing these two readings. It is also reasonably well known that a transistor may be considered as a sort of two-diode device as shown in figure 8-4. To illustrate them, let us assume we wish to check a low-power p-n-p transistor, represented by figure 8-4. One of the effective diodes, as shown in figure 8-4 (b) exists between base and collector connections; the other exists between base and emitter connection. Quite simply, if either of these diodes is defective (open or shorted), the transistor cannot function properly.
  - (b) For our first test, we connect the negative lead of the meter to the base of our p-n-p transistor and the positive lead to the collector. Since we are trying to force a current through the base-collector diode in the forward direction, we will get a low resistance reading if this diode is in good condition. The exact reading may vary depending on the characteristics of the ohmmeter as well as of the transistor, but a low-power type should generally read quite low, something like 120 ohms.
  - (c) In the second step, the base-emitter diode is checked by disconnecting the positive lead from the collector and connecting it to the emitter. Note that the forward resistance of the base-emitter diode is slightly higher than that of the base-collector diode, 140 ohms. This is normal for the low-power transistor.
  - (d) In the third step, we connect the positive lead of the meter to the base of the p-n-p transistor and the negative lead to the collector. Now we are trying to force a current through the base-collector diode in the reverse direction and we will get a high resistance reading if this diode is in good condition, generally in excess of 50,000 ohms. Noteworthy here is the high ratio of reverse to forward resistance -- in the order of 500:1 or greater. The two readings just referred to are test steps 1 and 3 of table 8-1 which is applicable to low-power p-n-p transistors.
  - (e) In the fourth step, the base-emitter diode is checked by disconnecting the negative lead from the collector and connecting it to the emitter. The resistance reading will be quite high if this diode is in good condition, generally in excess of 50,000 ohms. Note the high ratio of reverse to forward resistance -- in the order of 500:1 or greater. The two readings just referred to are test steps 2 and 4 of table 8-1.
  - (f) So far, the readings we have taken apply only to a minority of the transistors that would ordinarily be encountered. For one thing, nothing has been said of n-p-n types. For low-power units in this group, the base-collector and base-emitter diodes effectively have reversed polarity as compared to their counterparts in p-n-p transistors. We can check them by reversing the polarity of connections. When this is done (the first four lines of table 8-2 can be used as a guide to correct connections), the readings correspond to those obtained with the p-n-p transistors we are using for illustration.

## 8-2. Meter Usage - Continued

- (g) We must also take separate account of transistors designed to handle more power than those already considered. Those used in the audio-output and power-supply applications may fall into the medium-power and high-power class. However, circuit application is not a reliable guide. The manufacturer's ratings should be consulted when there is any doubt. Transistors with collector dissipation rated below 250 milliwatts may be considered low-power types. Where the rating exceeds 3 watts, we are dealing with high-power types.
- (h) To understand why power rating will affect resistance readings, we once more consider semiconductor diodes. A diode designed for use as an video or audio detector passes little current, whereas one intended for use as a power-supply rectifier will handle a current many times greater. This difference is reflected in both forward and reverse resistance readings. The detector diode will measure much higher than the power supply rectifier. Similarly transistors designed to handle greater power will pass more current and show lower resistance values.
- (i) Tables 8-3 and 8-4 give ohmmeter connections and typical resistances measured respectively on p-n-p and n-p-n medium-power types. Readings for high-power transistors are given in tables 8-5 and 8-6. Note how forward resistance of either diode sections, drops off from 120-140 to 80 and then 50 ohms as power rating increases. The same pattern is observed in reverse resistance readings. However, a helpful fact can be noted. Although there may be uncertainty concerning exact resistance readings obtained in any single measurement, there is a very clear relationship between forward and reverse resistance, with the latter being a few hundred times greater than the former. If this does not show up on a test, the transistor may be considered defective.

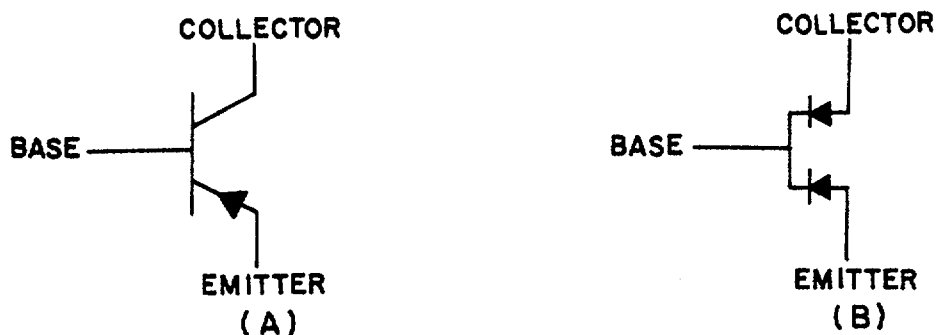

Figure 8-4. Transistor Shown as a Two-Diode Element

8-2. Meter Usage - Continued

Table 8-1. Low Power P-N-P Transistor Characteristics

Test step	Meter connections			Ohmmeter reading
	Emitter	Base	Collector	
1	none	-	+	120 ohms
2	+	-	none	140 ohms
3	none	+	-	50K ohms or greater
4	-	+	none	50K ohms or greater

Table 8-2. Low Power N-P-N Transistor Characteristics

Test step	Meter connections			Ohmmeter reading
	Emitter	Base	Collector	
1	none	+	-	120 ohms
2	-	+	none	140 ohms
3	none	-	+	50K ohms or greater
4	+	-	none	50K ohms or greater

Table 8-3. Medium Power P-N-P Transistor Characteristics

Test step	Meter connections			Ohmmeter reading
	Emitter	Base	Collector	
1	none	-	+	80 ohms
2	-	+	none	80 ohms
3	none	+	-	50K ohms or greater
4	-	+	none	50K ohms or greater

Table 8-4. Medium Power N-P-N Transistor Characteristics

Test step	Meter connections			Ohmmeter reading
	Emitter	Base	Collector	
1	none	+	-	80 ohms
2	-	+	none	80 ohms
3	none	-	+	50K ohms or greater
4	+	-	none	50K ohms or greater

**8-2. Meter Usage - Continued***Table 8-5. High Power P-N-P Transistor Characteristics*

Test step	Meter connections			Ohmmeter reading
	Emitter	Base	Collector	
1	none	-	+	50 ohms
2	+	-	none	50 ohms
3	none	+	-	30K ohms or greater
4	-	+	none	50K ohms or greater

*Table 8-6. High Power N-P-N Transistor Characteristics*

Test step	Meter connections			Ohmmeter reading
	Emitter	Base	Collector	
1	none	+	-	50 ohms
2	-	+	none	50 ohms
3	none	+	+	30K ohms or greater
4	+	-	none	50K ohms or greater

**8-3. Multimeter Familiarization.**

a. Front Panel (fig. 8-5). The instrument has a large easy to read, 4 1/2 inch meter scale at the top of the front panel. Below the meter are three operating controls and eight jacks.

b. Range Switch (fig. 8-5). The range switch, in the center of the lower part of the front panel, has 12 positions. It may be turned in either direction to obtain any desired range and circuit position. There are six voltage ranges for DC and six for AC, six ranges for direct current, and three resistance ranges.

c. Function Switch (fig. 8-5). The function switch is located at the left hand side of the lower part of the front panel. It has three positions: -DC, +DC, and AC. When direct current, DC voltage, or resistance is to be measured, the function switch may be set at -DC or +DC depending on the polarity of current or voltage. Reversing the test lead connections without removing them from the circuit is accomplished by the use of the function switch.

d. Zero Ohms (fig. 8-5). The control at the lower right hand side on the front panel is marked ZERO OHMS. This variable resistance in the ohmmeter circuit is used to compensate for the aging of the internal batteries.



## 8-3. Multimeter Familiarization - Continued

## NOTE

For the purpose of the discussion in this section, reference is made to a Simpson 260 series multimeter.

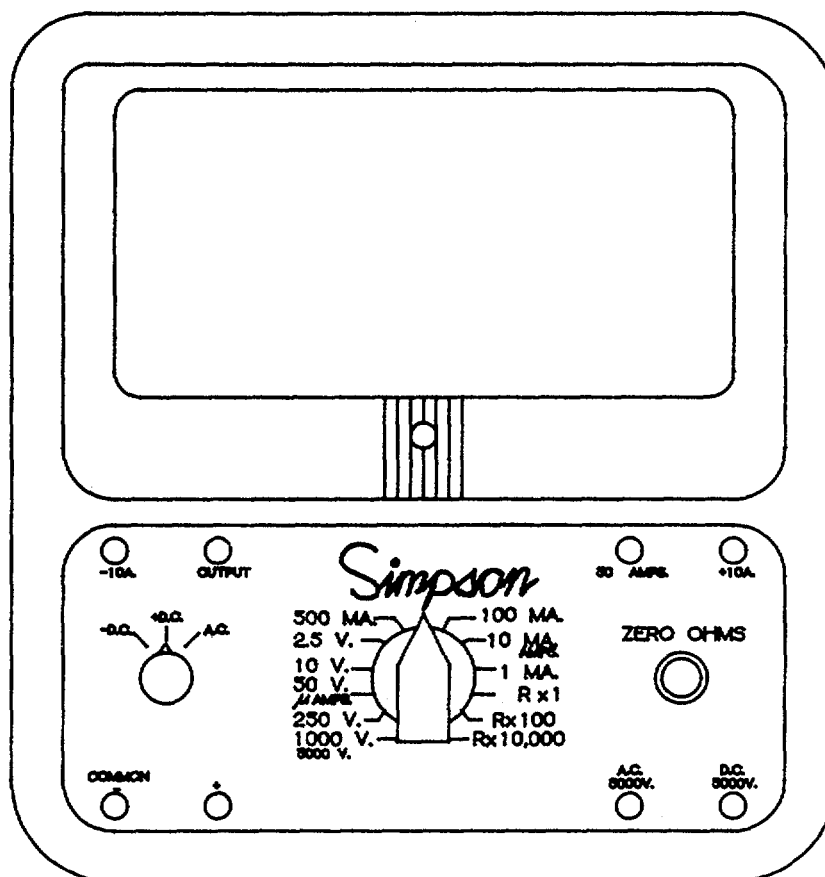

Figure 8-5. Simpson 260 Series - Multimeter

e. Circuit Jacks (fig. 8-5). There are eight jacks, two in each corner of the front panel. These are the connection points for the test leads. At the lower left corner are the COMMON - and + jacks. The black lead is connected to the COMMON - for all circuits and ranges except 10 amperes DC. The red test lead is connected to the + jack for all circuits and ranges except those designated by other jacks. Across the top of the panel are jacks marked -10A, OUTPUT, 50μAMP, and +10A. For all audio frequency output voltage ranges, use the red test lead connected to the OUTPUT jack. For the 50 microampere or 250 millivolt DC range, use the red test lead connected to the 50AMP jack. For the 10 ampere DC range, use the black test lead in the -10A jack and the red test lead in the +10A jack.

### 8-3. Multimeter Familiarization - Continued

f. Test Leads (fig. 8-5). Each instrument is furnished with one pair of four-foot test leads. One lead is black and the other is red for easy polarity identification. The insulation property of the test leads is a special high-grade rubber which has far more insulation strength than the largest voltage for which the instrument is rated.

### 8-4. Scale Interpretation.

a. Ohms Scale (fig. 8-6). This scale is a nonlinear scale used only for the purpose of reading resistance. Zero ohms is at the right end of the scale and moving across the scale to the left, the divisions become closer together. The extreme left end of the scale is marked infinity ( $\infty$ ). This represents a resistance beyond the range of the meter. It should be pointed out that for the purpose of accuracy, a range should be selected on the meter that will produce a pointer indication on the right-half of the ohms scale. The reason is obvious when observing the numbers on the right-half of the ohms scale. The numbers are spaced further apart with more graduations in-between the numbers, allowing for a more accurate reading.

b. DC Voltage Scales (fig. 8-6). The black scale, located directly beneath the ohms scale, is a linear scale used to measure +DC and -DC voltages and direct current. The scale divisions are equally spaced and start at the left with 0 and end at the right with 250. For the 2.5V range, use the 0-250 figures and divide by 100. For the 10V, 50V, and 250V ranges simply read the figures directly from the scale. For the 1000V range, use the 0-10 V range and multiply the readings by 100. For the 5000V range use the 0-50V range and multiply the reading by 100.

c. AC Voltage Scales (fig. 8-6). The root-mean-square (RMS) value of an AC voltage is measured on the red scale directly beneath the black DC scales. For the 0-2.5V range, read the value directly on the scale marked 2.5VAC only. For the 20V, 50V, and 250V ranges, read the red scale marked AC but use the black figures immediately above the red scale. For the 1000V range, read the red scale marked AC using the black 0-10 V range and multiply the reading by 100. For the 5000V range, read the red scale marked AC using the black 0-50 V range and multiply the reading by 100.

d. DB Scale (fig. 8-6). For some applications, output voltage and audio frequency voltage are frequently measured in terms of decibels. The decibel (DB) scale located at the bottom of the meter face is numbered from -20 through 0 and up to +10. For the 10V range, read the DB scale and add +12DB to the reading. For the 50V range, read the DB scale and add +26DB to the reading. For the 250V range, read the DB scale and add +40DB to the reading.

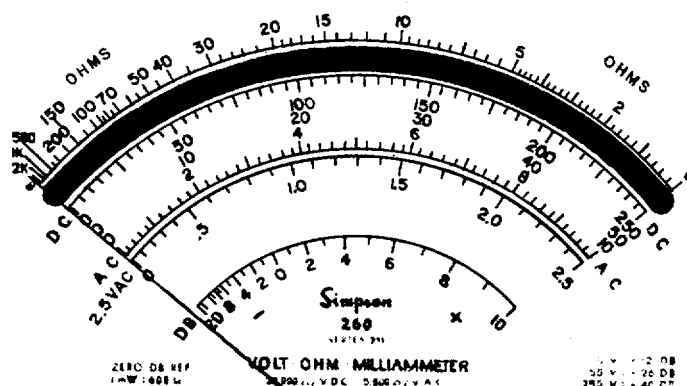

Figure 8-6. Multimeter Face

## Section II. OSCILLOSCOPE CHARACTERISTICS

### 8-5. Oscilloscope Familiarization.

a. General. The oscilloscope is used to visually display electrical impulses. Some oscilloscopes are designed specifically for displaying only one trace. These oscilloscopes are classified as single trace oscilloscopes and consist primarily of one vertical amplifier and one horizontal sweep generator connected to the deflection plates of the cathode-ray tube (CRT). The versatility of an oscilloscope can be increased by providing for more than one vertical amplifier and one horizontal sweep generator. A dual-trace oscilloscope contains this versatility by incorporating two plug in vertical amplifier units and a dual time base plug-in unit that contains main triggering controls. These provide dual trace operation for the comparison of two independent electrical impulses at the same time. When the recurring rate of a signal is so slow (a pulse recurring once every 30 seconds) that it becomes impossible to adequately observe it on a conventional oscilloscope, the storage oscilloscope should be used. The storage oscilloscope is designed to store the signal in its memory and then display the signal on the CRT for viewings or photographing. In addition, the storage oscilloscope can be operated as a conventional oscilloscope.

#### NOTE

**For the purpose of the discussion in this section, reference is made to an AN/USM 281C oscilloscope.**

b. Oscilloscope Controls (fig. 8-7). The controls for the oscilloscope are located in the front and rear panels. The most commonly used controls will be discussed in this section. The more complex controls will not be covered, these controls are for special applications. Refer to the operators manual of the particular oscilloscope you are using for their uses.

#### NOTE

**Perform the initial control settings before turning the oscilloscope on for the first time. Once the oscilloscope has been in use, it should not be necessary to repeat the initial control settings unless the front controls have been completely maladjusted.**

c. Initial Control Settings (fig. 8-8). Preposition the oscilloscope controls as follows:

- (1) Set INTENSITY knob (1) fully counterclockwise.
- (2) Turn FOCUS knob (2) to midrange.
- (3) Turn GRAT ILLUM knob (3) to midrange.

#### NOTE

**Be sure only one VERT MODE switch remains pressed in at a time.**

8-5. Oscilloscope Familiarization - Continued

- (4) Under the VERT MODE column set LEFT (14) by pressing in.

**NOTE**

Be sure only one TRIG SOURCE switch remains pressed in at a time.

- (5) Under the TRIG SOURCE column set VERT MODE (6) by pressing in.

- d. Vertical Amplifier Controls (fig. 8-9). Preposition controls as follows:

**NOTE**

The left vertical amplifier is used for this discussion, however, the right vertical amplifier

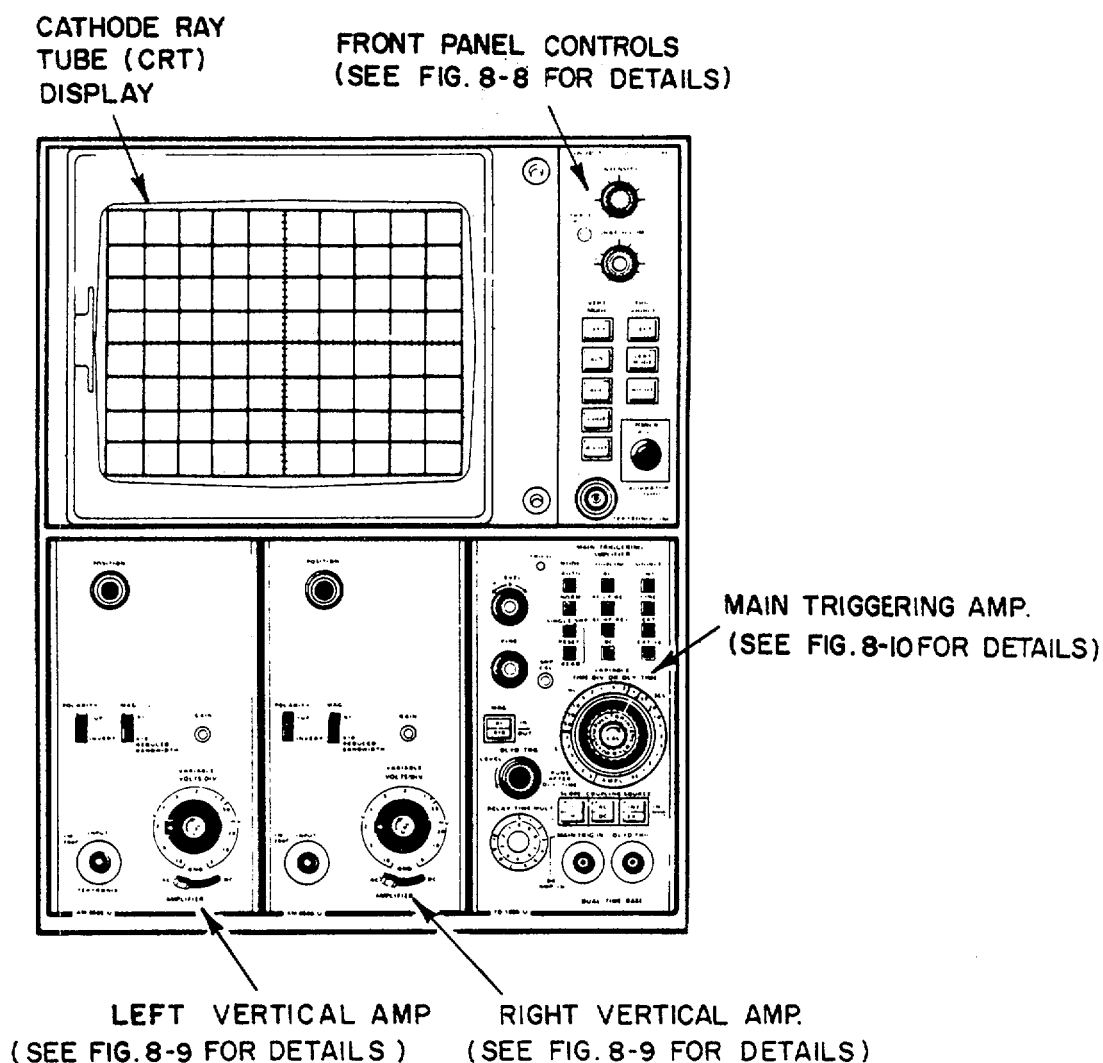
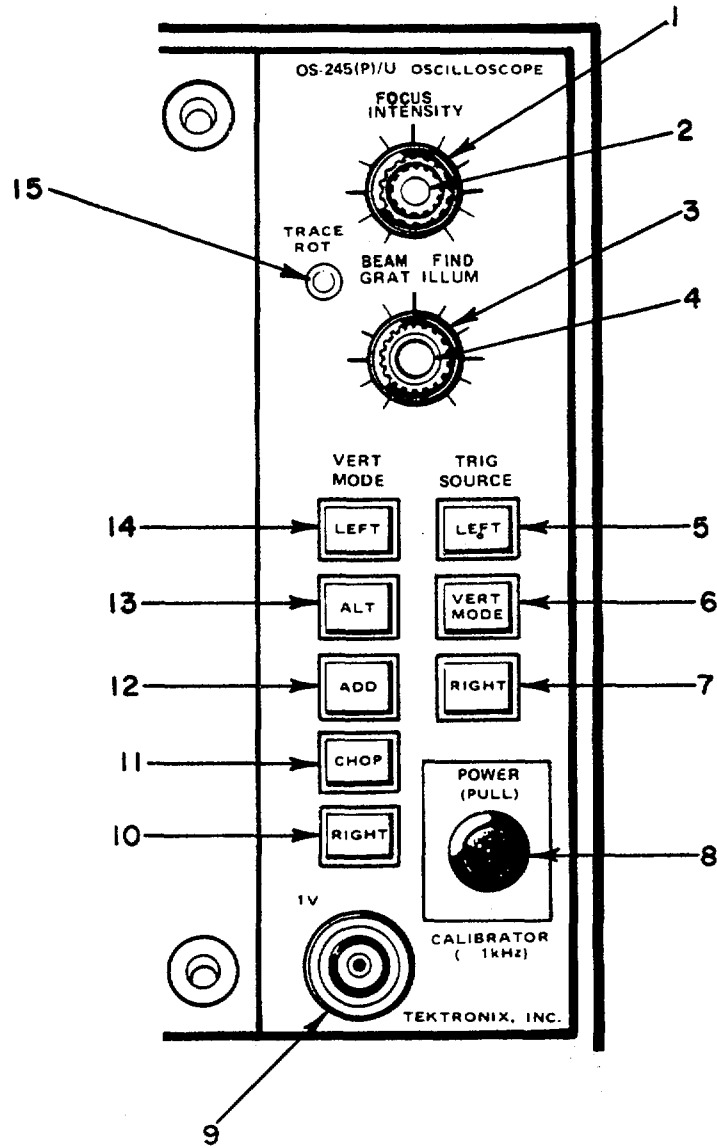

Figure 8-7. Oscilloscope Subassemblies

8-5. Oscilloscope Familiarization - Continued



KEY to figure 8-8:

- |   |  |
|---|--|
| 1. INTENSITY knob                           | 8. POWER switch                        |
| 2. FOCUS knob                               | 9. CALIBRATOR connector                |
| 3. GRAT ILLUM (Graticule illumination) knob | 10. RIGHT vertical mode                |
| 4. BEAM FINDER switch                       | 11. CHOP vertical mode                 |
| 5. LEFT trigger source                      | 12. ADD vertical mode                  |
| 6. VERTICAL MODE trigger source             | 13. ALT (Alternate) vertical mode      |
| 7. RIGHT trigger source                     | 14. LEFT vertical mode                 |
|   | 15. TRACE ROT control (Trace rotation) |

Figure 8-8. Front Panel Controls

## 8-5. Oscilloscope Familiarization - Continued

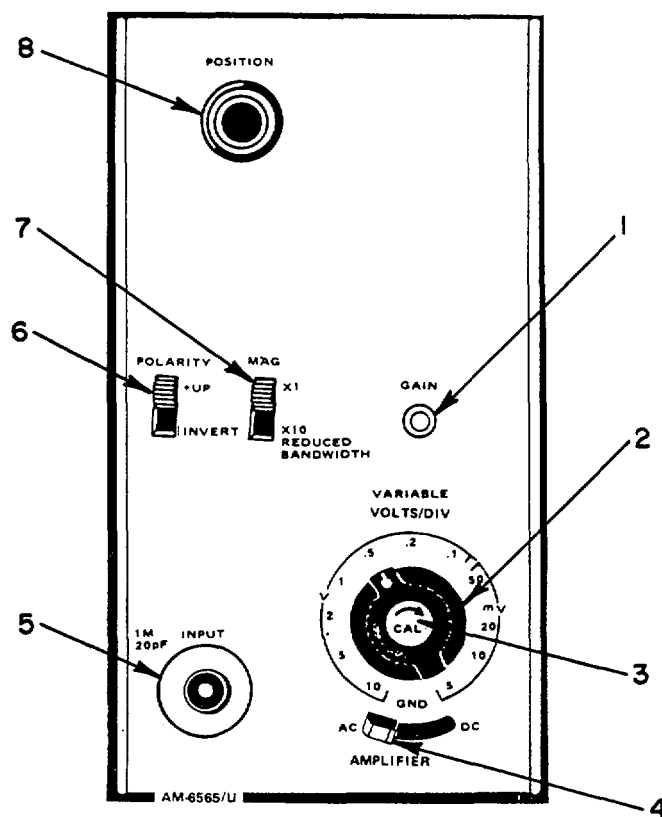

KEY to figure 8-9:

- |                                      |                               |
|--------------------------------------|-------------------------------|
| 1. GAIN control                      | 5. INPUT connector            |
| 2. VOLTS/DIV (Volts/division) switch | 6. POLARITY switch            |
| 3. CAL (Calibrate) knob              | 7. MAG (Magnification) switch |
| 4. AC GND DC (Input coupling) switch | 8. POSITION knob              |

Figure 8-9. Vertical Amplifier Controls

- (1) Set POSITION knob (8) to midrange. This control allows for vertical movement of displayed waveform.
- (2) Set POLARITY switch (6) to the + UP position.
- (3) Set MAG switch (7) to the X1 position.
- (4) Turn VOLTS/DIV switch (2) to the .5 position.
- (5) Turn CAL (RED KNOB) (3) fully clockwise until it clicks in place.
- (6) Set input coupling switch (4) to the AC position.

**8-5. Oscilloscope Familiarization - Continued**

e. MAIN TRIGGERING AMPLIFIER (fig. 8-10). Position controls as follows:

- (1) Turn LEVEL knob (15) to midrange.
- (2) Turn SLOPE knob (14) fully clockwise to +.
- (3) Set the MODE switch (17) to AUTO.
- (4) Set the COUPLING switch (1) to AC.
- (5) Set the SOURCE switch (2) to INT.
- (6) Turn POSITION knob (13) and FINE knob (12) to midrange. These controls allow for horizontal movement of displayed waveform.
- (7) Set magnification to X1 by depressing MAG pushbutton (11).

**NOTE**

**The TIME/DIV OR DLY TIME switch is four controls in one. Care must be taken to see that each is positioned properly.**

- (8) Set the inner most TIME/DIV switch (3) to lms position.
  - (9) Set the DLY TIME switch (4) to the lms position and push in.
  - (10) Turn CAL knob (5) fully clockwise until it clicks in place.
  - (11) Turn DLYD TRG knob (10) fully clockwise to RUNS AFTER DLY TIME.
  - (12) Set the SLOPE (8) to +, COUPLING (7) to AC and SOURCE (6) to INT depressing pushbuttons.
  - (13) Turn DELAY TIME MULT knob (9) to the 0 position.
- f. Turn On and Adjustment for a Single Trace. Position the controls as follows:
- (1) Connect oscilloscope power cord to a power source of proper voltage.
  - (2) Pull POWER switch (8, fig. 8-8) out to apply power to the oscilloscope. Allow the scope to warm up for at least five minutes. Turn GRAT ILLUM knob (3, fig. 8-8) until the scale of the CRT is visible.

**NOTE**

**If a display is visible after completing step (3) below, proceed to step (9).**

- (3) Turn INTENSITY knob (1, fig. 8-8) clockwise until display is visible on the CRT.
- (4) Press and hold BEAM FIND switch (4, fig. 8-8).

8-5. Oscilloscope Familiarization - Continued

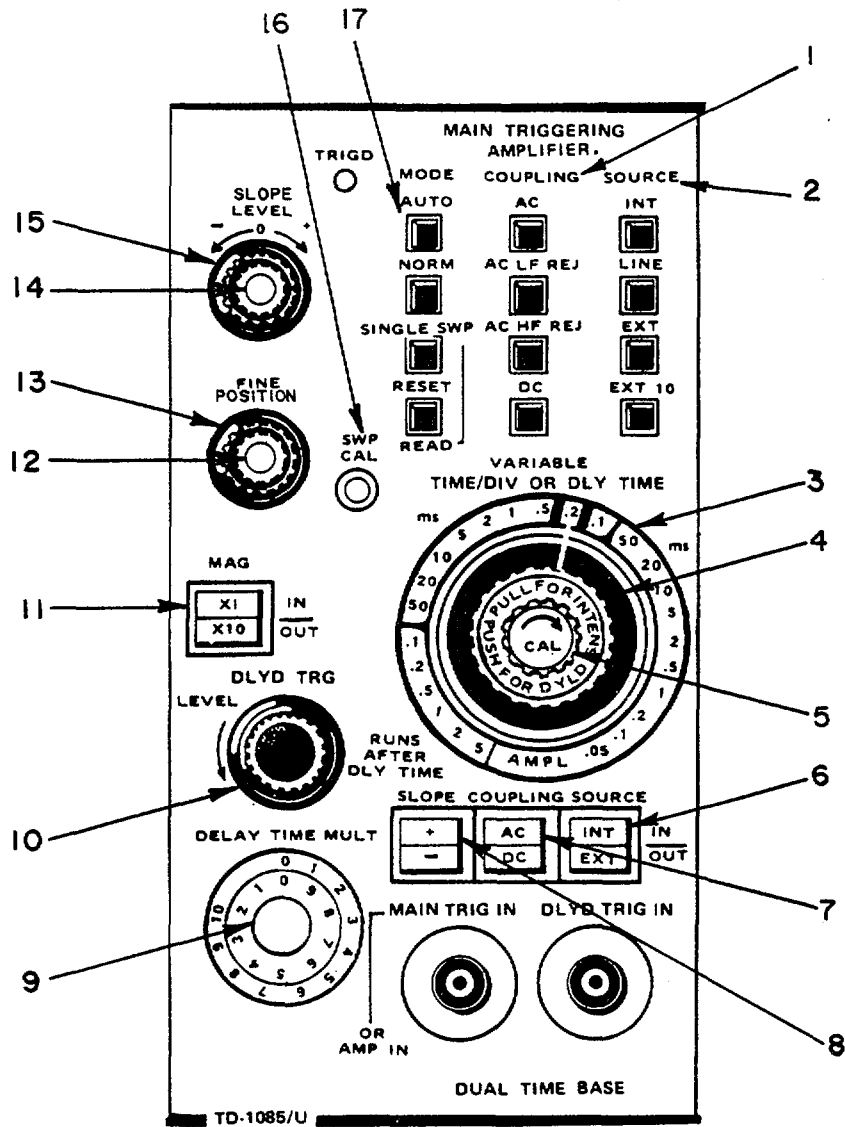

Key to figure 8-10:

- |                                    |                                       |
|------------------------------------|---------------------------------------|
| 1. COUPLING switch                 | 10. DLYD TRG (Delayed trigger) knob   |
| 2. SOURCE switch                   | 11. MAG (Magnification) pushbutton    |
| 3. TIME/DIV (Time/division) switch | 12. FINE knob                         |
| 4. DYL TIME (Delay time) switch    | 13. POSITION knob                     |
| 5. CAL (Calibrate) knob            | 14. SLOPE knob                        |
| 6. SOURCE pushbutton               | 15. LEVEL knob                        |
| 7. COUPLING pushbutton             | 16. SWP CAL (Sweep calibrate) control |
| 8. SLOPE pushbutton                | 17. MODE switch                       |
| 9. DELAY TIME MULTI knob           |                                       |

Figure 8-10. Main Triggering Amplifier



### 8-5. Oscilloscope Familiarization - Continued

- (5) Set VOLTS/DIV switch (2, fig. 8-9) for a display that remains within the vertical area of screen.
- (6) Adjust POSITION knob (8, fig. 8-9) for desired vertical position of display.
- (7) Adjust POSITION knob (13, fig. 8-10) for desired horizontal position of display.
- (8) Release BEAM FIND switch (4, fig. 8-8).
- (9) If necessary, adjust LEVEL knob (15, fig. 8-10) for a stable display.
- (10) Adjust FOCUS knob (2, fig. 8-8) for a well defined display on the screen.

### 8-6. Waveform Reading.

a. General. By analyzing a waveform that is displayed on the oscilloscope CRT, and observing the position of various control settings, the voltage amplitude, time between pulses, and frequency of the displayed waveform can be determined.

b. Measuring Signal Amplitude. Amplitude of a displayed signal is always measured along the vertical axis of the graduated scale on the face of the CRT.

#### NOTE

The following steps apply only to measuring the amplitude of signals displayed on the oscilloscope.

- (1) Perform TURN ON procedures stated in paragraph 8-5f.
- (2) Depress LEFT vertical mode (14, fig. 8-8).
- (3) The TIME/DIV OR DLY TIME switch (fig. 8-11) consists of four controls in one. Set the CAL knob fully clockwise until it clicks. Set the innermost TIME/DIV switch to the .2ms position. Set the PULL FOR INTENS PUSH FOR DYLD SWITCH to the .2ms position and push in. This means that each horizontal square will equal .2 milliseconds of time.

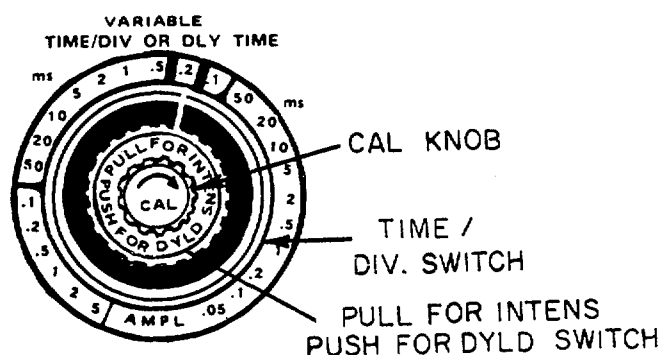

Figure 8-11. TIME/DIV or DLY TIME Control

## 8-6. Waveform Reading - Continued

- (4) Place input coupling AC/GND/DC switch, on the left vertical amplifier, to the AC position (fig. 8-12).

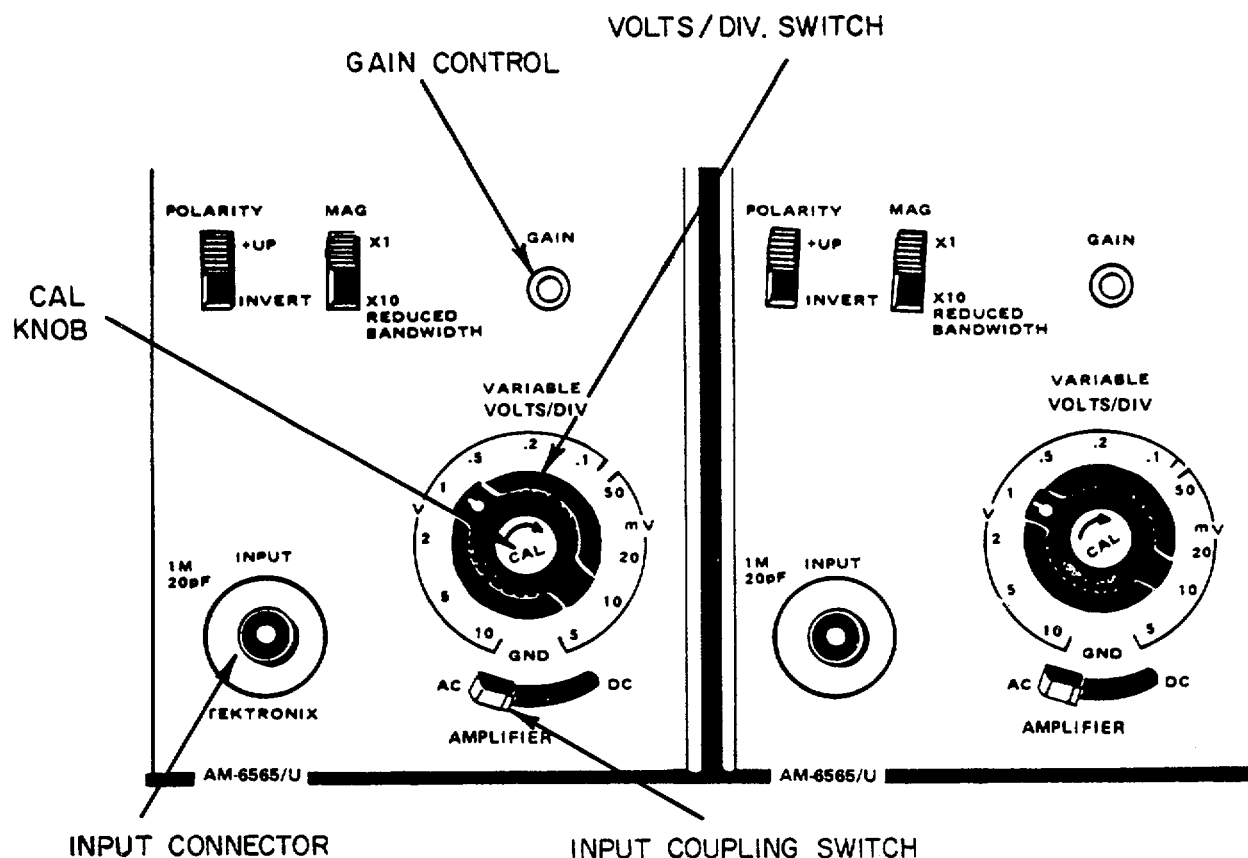

Figure 8-12. VOLTS/DIV Control

- (5) Set the VOLT/DIV switch (2, fig. 8-9) to the .5 volt position. This means that each vertical square is equal to .5 volts of input signal.
- (6) Turn the CAL KNOB (3, fig. 8-9) fully clockwise until it clicks.
- (7) Obtain a cable with a BNC connector on each end and connect one end to the CALIBRATOR (9, fig. 8-8) and the other end to the INPUT connector of the left vertical amplifier (fig. 8-12).
- (8) You should have two complete cycles of square wave displayed on the screen as shown in figure 8-13. It may be necessary to adjust the LEVEL control, (15, fig. 8-10) to obtain a stable display. Adjust both POSITION knobs (8, fig. 8-9) and (13, fig. 8-10) to center the displayed waveform.

## 8-6. Waveform Reading - Continued

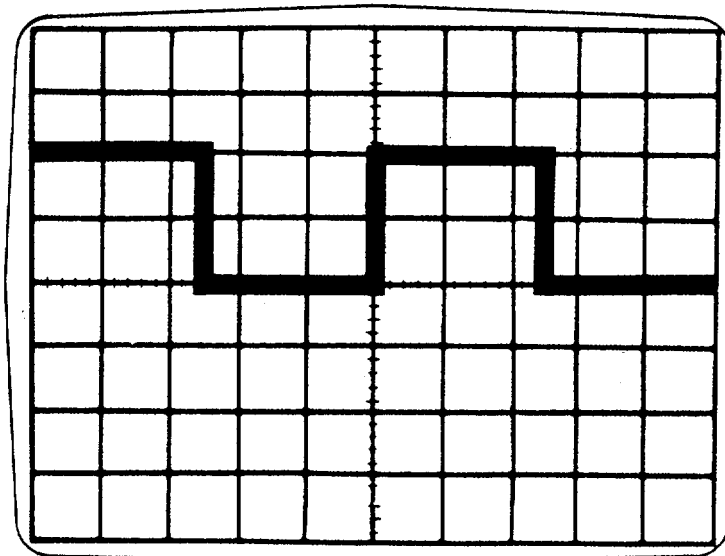

Figure 8-13. Square Waveform Display

- (9) If the waveform shown in figure 8-13 is not exactly 2 divisions or grid squares high, gain of the vertical amplifier should be adjusted. Use a small screwdriver and adjust the GAIN control (fig. 8-12) for a waveform exactly 2 divisions high (1 volt peak-to-peak).
- (10) The number of divisions or grid squares, that the signal covers in the vertical direction, times the setting of the VOLTS/DIV switch (fig. 8-12) equals the peak-to-peak voltage amplitude of the input signal.

**NOTE**

**An oscilloscope which has dual trace capability contains two vertical amplifiers, a left and right vertical amplifier. The right vertical amplifier has the same controls and functions as the left vertical amplifier.**

- (11) To use the right input and vertical amplifier, you must depress RIGHT vertical mode (10, fig. 8-8).

c. Time and Frequency Measurements. The time and frequency of a waveform is always measured along the horizontal axis of the graduated scale on the face of the CRT.

**NOTE**

**The following steps apply only to time and frequency measurement of waveforms displayed on the oscilloscope.**

### 8-6. Waveform Reading - Continued

- (1) Check the calibration of the scope horizontally, using a signal of known frequency. The output frequency of the CALIBRATOR (9, fig. 8-8) is 1000 Hz with a voltage of 1 volt peak-to-peak.
- (2) Turn the TIME/DIV OR DLY TIME switch (3, fig. 8-10) to the .1ms position. One cycle should be displayed on the CRT.
- (3) Rotate the SWP CAL control (16, fig. 8-10) until the displayed waveform of one cycle covers exactly 10 divisions horizontally as shown in figure 8-14.

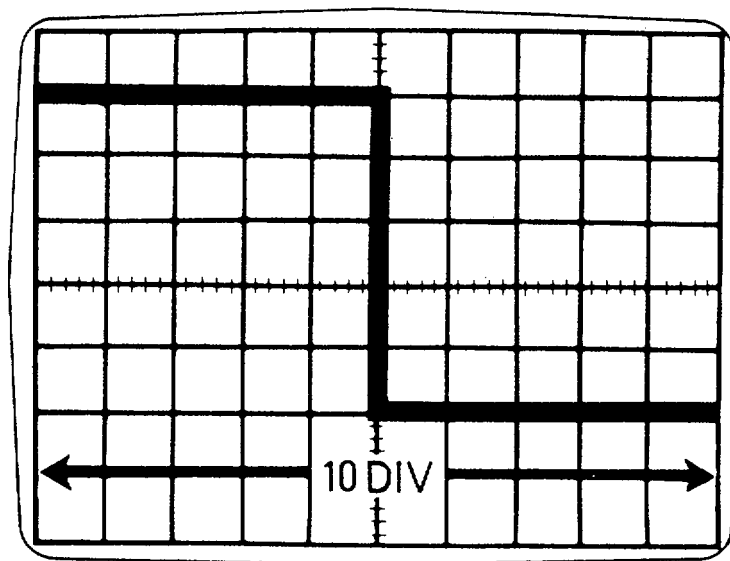

Figure 8-14. Calibrated Signal Display

- (4) To calculate the frequency of a signal you must first find the time of one complete cycle of displayed waveform. To do this you must use the controls of the main triggering amplifier (fig. 8-10).
- (5) The TIME/DIV switch (3, fig. 8-10) controls the horizontal display time of the oscilloscope.

#### NOTE

Whenever you change the input signals to the vertical amplifier or the positioning of the TIME/DIV switch (3, fig. 8-10) it may be necessary to adjust the LEVEL knob (15, fig. 8-10) to stabilize the displayed signal.

**8-6. Waveform Reading - Continued**

- (6) One complete cycle should be displayed on the CRT (fig. 8-14). Before you can calculate the frequency, you must first compute the time duration of one complete cycle. Count the number of divisions of horizontal deflection for one complete cycle and use the following formula to determine frequency.

$$\text{TIME DURATION} = \frac{\text{(HORIZONTAL DEFLECTION)}}{\text{(IN DIVISIONS FOR 1 CYCLE)}} \times \text{(HORIZONTAL SWEEP)} \text{ (SETTING IN SECONDS)}$$

EXAMPLE:

$$\text{TIME DURATION} = (10 \text{ DIVISIONS}) \times (.1 \text{ MILLISECONDS PER DIVISIONS})$$

$$\text{TIME DURATION} = 1.0 \text{ MILLISECONDS}$$

To determine the frequency, use the following formula:

$$\text{FREQUENCY} = \frac{1}{\text{TIME DURATION}} = \frac{1}{.001} = 1000\text{Hz}$$

(IN HERTZ)                      (IN SECONDS)

**8-7. Oscilloscope Probes.**

a. General. When a waveform is to be analyzed, a probe may be used. Most probes have more than one tip which can be inserted on the end of the probe, figure 8-15. These tips may be changed by unscrewing them from the end of the probe and screwing the desired tip in place. A ground strap is also supplied with the probe. The spring clip of the grounding strap clamps over the bared portion of cable at the upper end of the probe. The other end of the ground strap uses an alligator clip for connection to chassis ground of the equipment under test. This completes the ground connection between equipment under test and the oscilloscope.

b. Attenuation Factor. A probe may have an attenuation factor of ten or one hundred. The signal amplitude is reduced by the attenuation factor of the probe. This is done to allow for the measurement of signal amplitudes which exceeds the rated input capability of the vertical amplifier input channel. When using a probe which has attenuation, an additional step must be added to the procedure for computing the voltage:

- (1) Count the number of divisions of vertical deflection.
- (2) Multiply number of divisions by the setting of the VOLT/DIV switch (2, fig. 8-9).
- (3) Multiply the results of step (2) above by the attenuation factor of the probe. The result equals the peak-to-peak voltage of the displayed signal.

c. Probe Calibration (fig. 8-16). When a probe is used with an oscilloscope for the first time or when it is transferred from one plug in unit to another, the probe must be adjusted or calibrated. This will insure accurate attenuation of signals. Calibrate the probe as follows:

8-7. Oscilloscope Probes - Continued

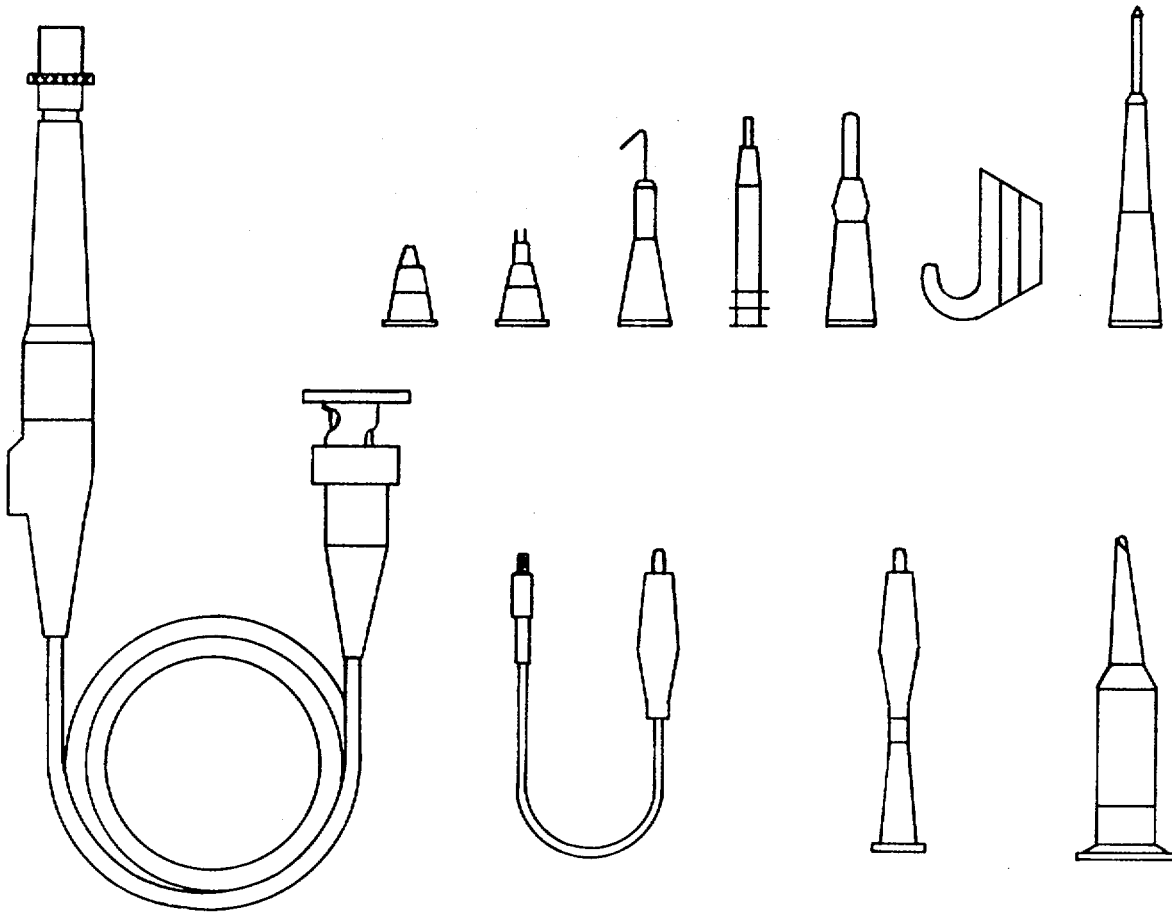

Figure 8-15. Oscilloscope Probes

- (1) Touch the probe tip to the center calibrator output jack (9, fig. 8-8) and adjust oscilloscope to display several cycles of the signal.
- (2) Loosen the locking sleeve (fig. 8-16) and turn the probe body and tip assembly until the correct waveform is displayed on the screen.
- (3) After the correct adjustment has been made, hold the probe body (fig. 8-16) and tighten the locking sleeve.

8-7. Oscilloscope Probes - Continued

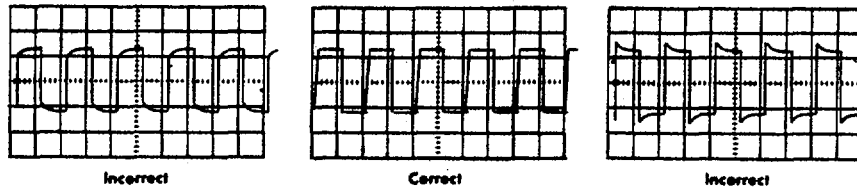
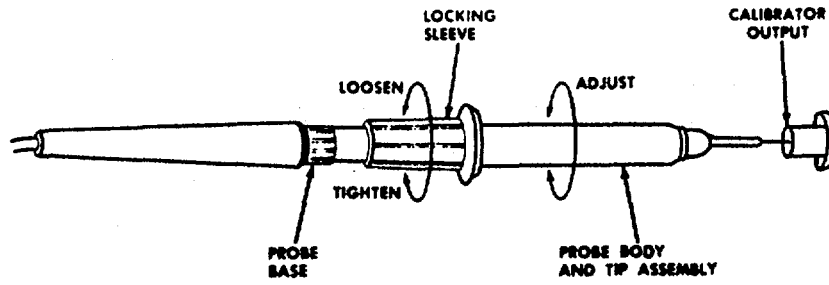

Figure 8-16. Probe Adjustment and Waveforms

Section III. POWER SUPPLY CHARACTERISTICS

8-8. Direct Current (DC) Power Supply.

a. General. A DC power supply (fig. 8-17) is a conversion device which converts alternating current from a primary source into direct current for use as a power source for various pieces of electronic equipment.

b. Control Function (fig. 8-17). A description of the various controls and their functions is as follows:

- (1) DC VOLTS meter (1) indicates the amount of dc voltage that is present at the output terminals (4 and 5).
- (2) DC AMPS meter (2) indicates the amount of dc current that is supplied at the output terminals (4 and 5).

## 8-8. Direct Current (DC) Power Supply - Continued

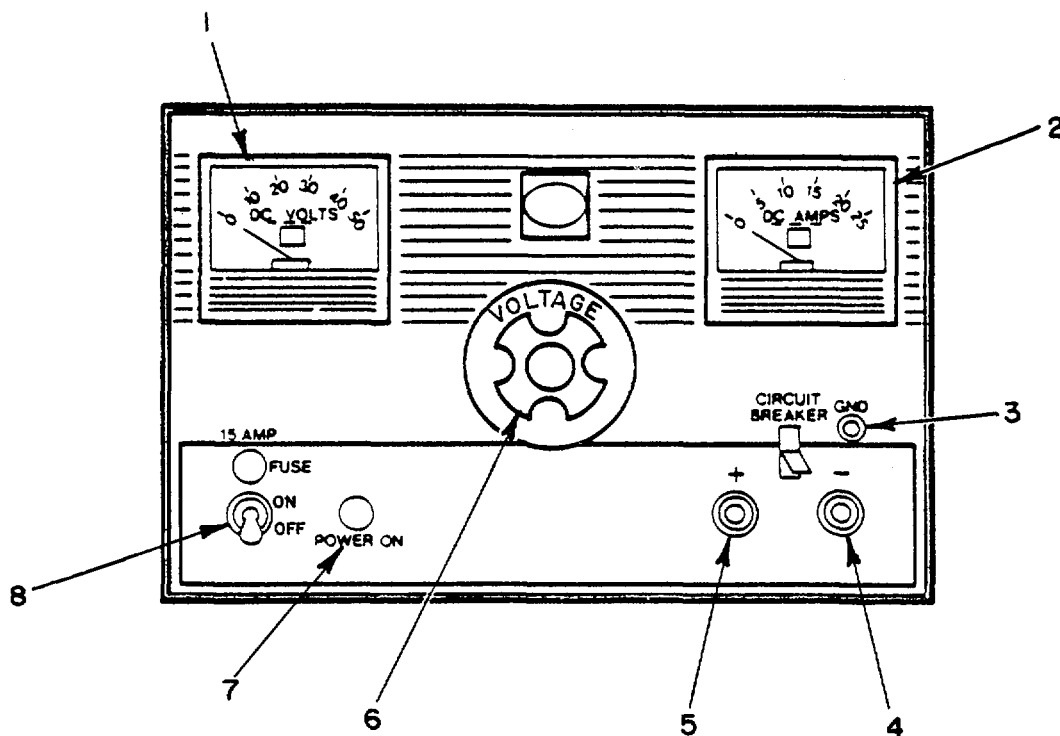

KEY to figure 8-17:

- |                                 |                                 |
|---------------------------------|---------------------------------|
| 1. DC VOLTS meter               | 5. + (positive) output terminal |
| 2. DC AMPS meter                | 6. VOLTAGE adjust knob          |
| 3. GND (Ground) terminal        | 7. POWER ON lamp                |
| 4. - (negative) output terminal | 8. ON-OFF switch                |

Figure 8-17. DC Power Supply

- (3) Ground terminal (3) is for a ground lead connection between the power supply and the equipment being supplied voltage.
- (4) - output terminal (4) is for a lead connection between the power supply and negative terminal of the equipment being supplied voltage.
- (5) + output terminal (5) is for a lead connection between the power supply and positive terminal of the equipment being supplied voltage.
- (6) VOLTAGE adjust knob (6) will increase the current and voltage output at terminals (4 and 5) when rotated clockwise.
- (7) POWER ON lamp (7) lights when primary power is applied to the power supply.
- (8) ON-OFF switch (8) supplies primary power to the power supply when placed in the ON position.



**8-8. Direct Current (DC) Power Supply - Continued**

c. Power Supply Setup (fig. 8-17). The proper procedure for setting up and connecting a power supply to a circuit is as follows:

- (1) Be sure the ON-OFF switch (8) is in the OFF position.
- (2) Connect power supply cord to a power source of proper voltage and frequency.
- (3) Turn the VOLTAGE adjust knob (6) fully counterclockwise.

**CAUTION**

**Always check for the proper polarity of voltage necessary to operate the equipment or chassis. Failure to observe voltage polarity could result in damage to equipment or chassis.**

- (4) Connect one end of a lead to the - output terminal (4). Connect the other end of the lead to the appropriate terminal of the equipment or chassis.
- (5) Connect one end of a lead to the + output terminal (5). Connect the other end of the lead to the appropriate terminal of the equipment or chassis.
- (6) Connect one end of a lead to the GND terminal (3) and connect the other end to the equipment ground.
- (7) Turn ON-OFF switch (8) to the ON position. Power ON lamp (7) will light.

**NOTE**

**To verify that the DC VOLTS meter is indicating properly, use a Multimeter across the + and - output terminals to read the dc voltage while adjusting the output.**

- (8) Turn the VOLTAGE adjust knob (6) slowly clockwise until the DC VOLTS meter (1) indicates the desired voltage.
- (9) When finished with the power supply, turn the VOLTAGE adjust knob (6) fully counterclockwise.
- (10) Turn ON-OFF switch (8) to the OFF position.
- (11) Disconnect leads from the equipment and the power supply.

## Section IV. ELECTROSTATIC DISCHARGE (ESD) AWARENESS

### 8-9. General Information.

a. Scope. It is essential to understand the nature of electrostatic discharge (ESD), what causes it, and the problems it can cause. This section contains information on the areas of major concern.

b. Basic Definitions.

- (1) **Electrostatic Discharge (ESD)**. A sudden and rapid transfer of electrons or charge between two objects. An example of ESD is the shock received after walking across a carpet and touching a metallic object, like a door knob.
- (2) **Electrostatic Discharge Sensitive (ESDS) Items**. All noninstalled electronic components, circuit cards and assemblies with sensitive labels. Items that fall within the Federal Supply Class (FSC) 5905, 5960, 5961, or 5962 should be treated as sensitive unless known to be otherwise.
- (3) **ESD Protective Material**. Conductive, antistatic, and static dissipative are all types of materials that are used to protect against ESD. Static dissipative materials are preferred because the charge dissipates across the surface at a controlled rate.

c. Typical Prime Charge Sources. Means of generating electrostatic charges (voltage) and their relationship to relative humidity are shown in table 8-7.

*Table 8-7. Means of Static Charge Generation and the Associated Voltages*

MEANS OF STATIC GENERATION AND PERCENTAGE OF RELATIVE HUMIDITY	ELECTROSTATIC VOLTAGES WITH	
	10 - 20 % RELATIVE HUMIDITY	65 - 90 % RELATIVE HUMIDITY
WALKING ACROSS CARPET	35,000	1,500
WALKING ON VINYL FLOOR	12,000	250
WORKER AT WORKBENCH	6,000	100

**Change 3 8-26**

**8-9. General Information - Continued***Table 8-7. Means of Static Charge Generation and the Associated Voltages - Continued*

MEANS OF STATIC GENERATION AND PERCENTAGE OF RELATIVE HUMIDITY	ELECTROSTATIC VOLTAGES WITH	
	10 - 20 % RELATIVE HUMIDITY	65 - 90 % RELATIVE HUMIDITY
VINYL ENVELOPES FOR WORK INSTRUCTIONS	7,000	600
COMMON POLY BAG PICKED UP FROM BENCH	20,000	1,200
WORK CHAIR PADDED WITH POLYUREATHANE FOAM	18,000	1,500

d. Prime Charge Carriers. Personnel are the prime charge carriers, with the greatest potential of damaging ESD items. Activities such as walking, working at a table or bench, sliding on a chair, or simply combing one's hair can generate static charges of thousands of volts with high potential for damage to sensitive devices.

e. Items to Avoid. The following items will generate sufficient charges to damage sensitive items: All common plastics, spray cans, tape dispensers, heating guns, bubble pack, polystyrene cups, cigarette papers and wrappers, paint cans, stencil ink applicators, common poly bags and sheets, and plastic tape.

**8-10. ESD Handling, Labeling and Packaging.**

a. Handling Unpackaged ESD Sensitive Items. Never store or transport ESD sensitive components or assemblies outside of the protective packaging. The protective packaging should not be opened or removed until the item is to be installed in the next higher assembly. At this time, the technician should be grounded in an approved work station. Avoid touching bare leads and contacts on sensitive material. Never use plastic solder suckers to remove soldered components from ESD sensitive assemblies. Use metallic or antistatic solder removal means.

b. Packaging and Labeling ESD Sensitive Items/Assemblies. After replacement of a sensitive circuit card assembly (CCA) or other subassembly into instrument, a CCA/sensitive item that is to be returned for repair must be

**Change 3 8-27**

repackaged in ESD protective material to prevent further damage from handling and transit. For field returns, antistatic ziplock bags are available for CCAs and other small assemblies. The container with the ESD sensitive material warning label should also be used for returning defective material to ensure proper handling during shipment.

- c. Types of ESD Sensitive Devices. Table 8-8 lists devices.

*Table 8-8. Device Type and Range of ESD Susceptibility (VOLTS)*

<b>DEVICE TYPE</b>	<b>RANGE OF SUCEPTABILITY (VOLTS)</b>
VMOS	30 to 1800
MOSFET	100 to 200
GaAsFET	100 to 300
EPROM	100
JFET	140 to 7000
SAW	150 to 500
OP AMP	190 to 2500
CMOS	250 to 3000
Schottky Diodes	300 to 2500
Film Resistors	300 to 3000
Bipolar Transistors	380 to 7000
ECL (PC Board Level)	500 to 1500
SCR	680 to 1000
Schottky TTL	1000 to 2500

**Change 3 8-28**

**8-11. ESD Protective Work Station.****WARNING****Do not use grounded protective work station for testing.**

a. Army Adopted Configuration. In general, it must occupy a 10-foot square area, cordoned off with yellow lines or other means of segregation. The area should be posted with signs identifying it as a static-free work area. This protective station may be used for packaging or by maintenance personnel for repairing sensitive devices, but not when applying power to the instrument for testing. Refer to figure 8-18 for a sketch of the grounded packaging and/or repair work station layout.

b. Precautions Within 20-Foot Distance. For purposes of initially established worksites, the major controlled area shall be considered as that area within a 20-foot radius of the bench(es). Within this controlled area, the following shall be excluded:

- (1) Materials handling trucks, carts, and equipment.
- (2) Conveyor drive mechanisms and moving belts.
- (3) Sandblast and air-cleaning equipment.
- (4) Paint spray booths and ventilating equipment.

(5) Storage of bulk common plastic materials such as large rolls of cushion wrapping material, loose fills, slab cushioning, or fastpacks.

c. Precautions Within 50-Foot Distance. A special hazard exists in areas where stretch and shrink wrapping operations are performed. This is also true where skin packaging, foam-in-place, and plastic bagging are conducted. These functions must be kept at least 50-feet away from static protected sites.

d. Chairs. Chairs are generally not recommended within the protected areas. If used, due to physical impairment of personnel, they must be of conductive construction, making good electrical contact with the grounded floor material, and must have conductive seat covers.

**Change 3 8-29**

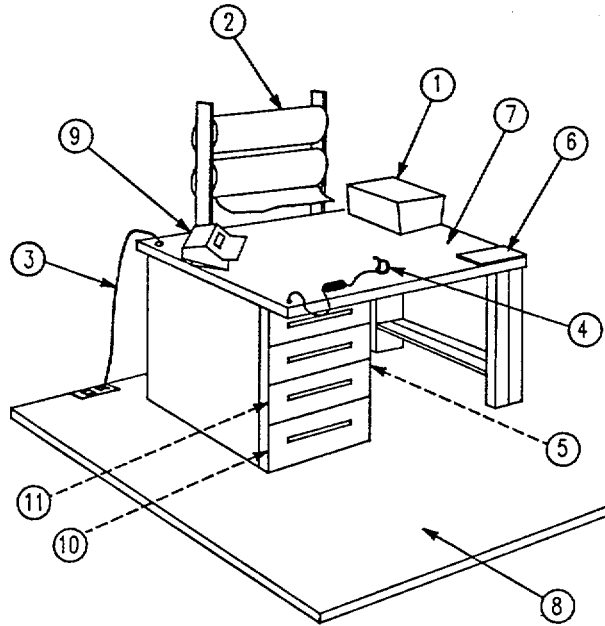

**NOTE**

**Items 5, 10, and 11 are not show directly, 10 and 11 being stored within the drawers of the bench.**

**LEGEND**

- |  |  |
|--|--|
| <p>1 Conductive tote boxes lined with antistatic or static dissipative material.</p> <p>2 ESD protective wrapping and film materials.</p> <p>3 Grounding strap from conductive table top to common ground at conductive floor mat.</p> <p>4 Conductive wrist strap to ground with a one megohm resistor imbedded in line.</p> <p>5 Parts carriers, mailers, shunting devices, etc.</p> <p>6 Precautionary signs.</p> | <p>7 Conductive table top in the range of <math>10^6 - 10^8</math> ohms per square.</p> <p>8 Conductive floor mat in the range of zero to <math>10^4</math> ohms per square.</p> <p>9 Air ionizers (to bring all materials entering the work area to equal potentials.)</p> <p>10 Chair covers and shoe grounders or heel straps.</p> <p>11 Warning labels for packages.</p> |
|--|--|

*Figure 8-18. ESD Protective Workstation (2 Operator Station shown)*

**Change 3 8-30**

## CHAPTER 9

### OPTICAL DATA

---

#### Section I. DEFINITION OF COMMON OPTICAL TERMS

##### 9-1. Optical Terms.

a. Aberration. An aberration is any defect of a lens or optical system which causes the image to be imperfect. There are six general types of aberrations which are defined and listed below.

- (1) Chromatic aberration causes colored fringes around the borders of objects seen through the lens.
- (2) Coma is an aberration which causes oblique pencils of light from a point on the object to be imaged as a comet-shaped blur instead of a point.
- (3) Curvature of image is an aberration which causes an image to be focused in a curved plane instead of a flat plane.
- (4) Astigmatism is an aberration which causes the lens to have more than one focal point of the object being viewed.
- (5) Distortion is an aberration which causes the objects being viewed to appear misshapen or deformed.
- (6) Spherical aberration exists when rays of light passing through a lens near its edge are focused to a point nearer the lens than those rays passing through the lens near the center. The effect of this aberration is poor definition of the image being viewed.

b. Auto-Collimation. Establish a line-of-sight perpendicular to a mirror with an infinity setting of the telescope. This is a process used, in the set up of test fixtures, to insure the proper alignment of the projector collimator and the test adapter being used. Auto-collimation is accomplished by placing a front surface mirror on the mounting surface of the test adapter, in front of the objective end of the collimator. Then while sighting through the eyepiece of the collimator, position the collimator so that its reticle is superimposed on the reflected reticle image.

c. Collimation. The process of aligning the axis or center of an optical system to the mechanical axis of an instrument.

d. Converge. In a lens this means to deviate light rays toward a common center or focal point as shown in figure 9-1. When applied to binoculars or any stereoscopic instrument, it means to align the line-of-sight of each side of the instrument to meet at a common focus to obtain a single image.

e. Diopter. A unit of optical measurement which indicates the refractive power of a lens or prism. The shorter a lens's focal length the greater power in diopters it will have.

f. Diverge. In a lens this means to deviate the light rays outward from a common center in different directions, as shown in figure 9-2.

## 9-1. Optical Terms - Continued

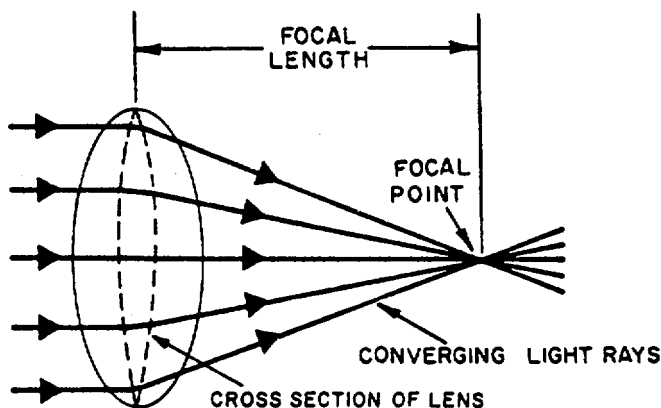

Figure 9-1. Deviation of Light Rays Through a Converging Lens

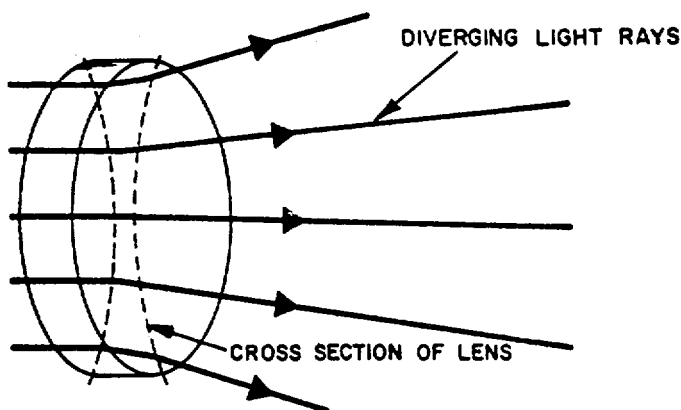

Figure 9-2. Deviation of Light Rays Through a Diverging Lens

g. Field-of-View. The true field-of-view of any optical instrument is the extent (the width and height) of what can be seen at one time by looking through the instrument.

h. Focal Length. The distance from the focal point back to the surface of a mirror or optical center of a lens, as shown in figure 9-1.

i. Focal Point. The point at which rays of light converge when they pass through a lens, as shown in figure 9-1.

j. Focus. To adjust the eyepiece of a telescope, so that the image is clearly seen by the eye.

k. Newton's Rings. When positive (convergent) lens and negative (divergent) lens of slightly unequal curvature are pressed one against the other, irregular bands or patches of color appear between the surfaces of the two lenses, as shown in figure 9-3.

l. Parallax. Optically, parallax in a telescope with a reticle is any apparent movement of the reticle in relation to distant objects in the field-of-view observed by movement of the observer's head. This condition exists when the image in the telescope lies in one focal plane and the reticle lies in another.



9-1. Optical Terms - Continued

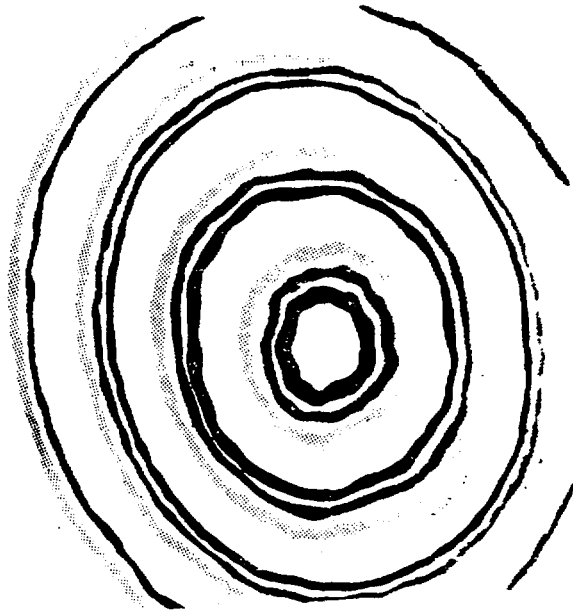

Figure 9-3. Newtons Rings

m. Parallax Shield. A device used to reduce parallax between the sighting instrument and the field of view. Placed over the eyepiece end of the instrument it will restrict the movement of the viewer's eye and minimize the apparent displacement of one object with respect to another, that is, the reticle and the target. The parallax shield (fig. 9-4) can be fabricated from cardboard, tape, or metal with approximately a 1/16 inch hole located in the center.

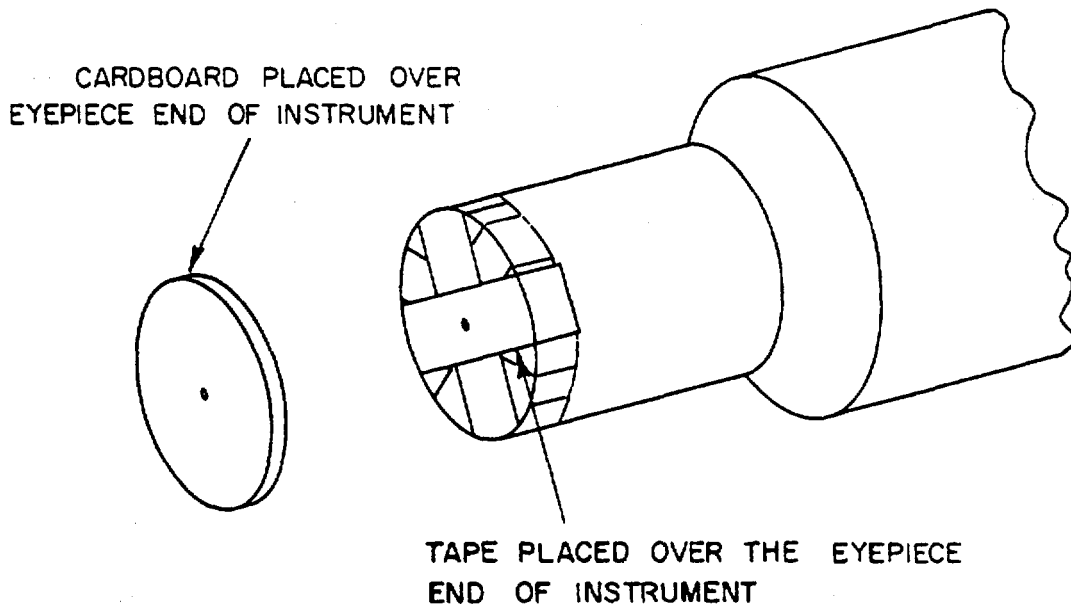

Figure 9-4. Parallax Shield

9-1. **Optical Terms - Continued**

n. Reflection. Light striking a surface and returning or bouncing back as shown in figure 9-5.

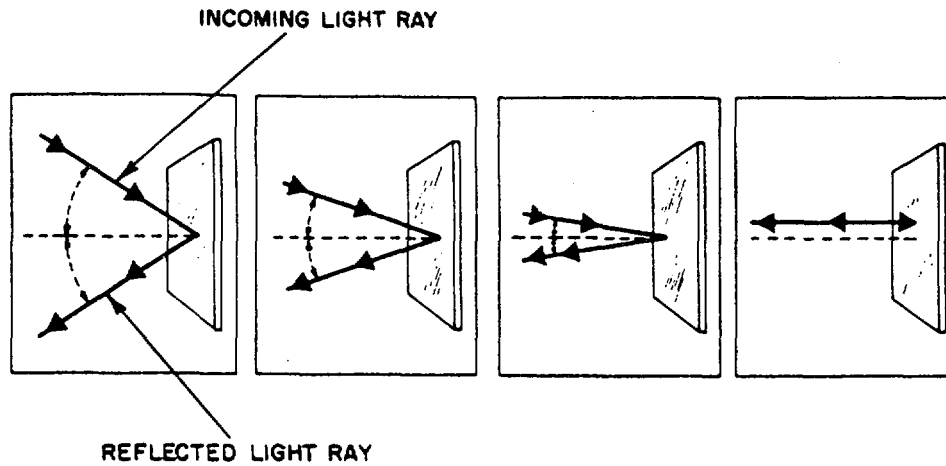

Figure 9-5. Reflection From a Plane Mirror

o. Refraction. The bending of light due to a change in speed which occurs when a ray of light passes from one medium to another of different optical density, as shown in figure 9-6.

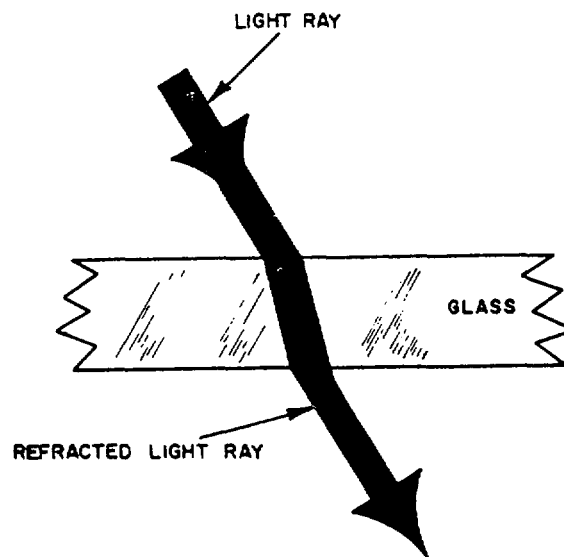

Figure 9-6. Effects of Refraction

p. Roll Test. A test usually performed on instruments such as telescopes or optical alignment devices which are required to rotate on bearing surfaces. The mechanical and optical axis of the instrument must be coincident of each other when rotated through 360 degrees.

q. Separation. This condition results when the cement between the surface of a compound lens breaks down. It shows up as jagged lines or streaks, yellowish in color between the two lenses.

## 9-2. Optical Components.

a. Lens. A transparent object, usually a piece of optical glass, having two polished surfaces of which at least one surface is curved. It is shaped so that rays of light, when passing through it, are made to converge or diverge. A lens can be made from a single piece of optical glass or it can be made of two or more pieces of glass cemented together. Some examples of lenses used in optical systems are listed below:

- (1) Erector lenses placed between the focal planes of the objective and the front focal plane of the eyepiece. Their function is to produce an erect or upright image which would otherwise be inverted and reverted.
- (2) The eyelens is located nearest the eye and is used to direct the light rays into the eye. This lens does the actual magnifying of the image and can affect the quality of the image as seen by the eye.
- (3) The field lens, located in the eyepiece nearest the objective, is used to gather light from the objective or erectors and converge it into the eyelens.
- (4) The objective lens is located in an optical system farthest from the eye. It receives light from the object being viewed to form an inverted and reverted image.
- (5) A window is a piece of glass with no refracting power (with parallel surfaces). Its function is to admit light into an optical instrument and to keep out dirt and moisture.

b. Diaphragm or Stop (fig. 9-7). A diaphragm is a flanged or plain ring, with a limited aperture, placed in an optical system at any of several points. They cut off marginal rays of light not essential to the field of view. The rays of light which cause aberrations, glare, and ghost images are eliminated by the use of diaphragms. There are three general uses of diaphragms which are defined as follows:

- (1) Aperture stops are diaphragms used to limit the aperture of light gathering power of the instrument.
- (2) Field stops are diaphragms placed in an image plane to reduce aberrations in the instrument.
- (3) Antiglare stops are used to eliminate reflections from the sides of the instrument tube and consequent glare in the fields-of-view.

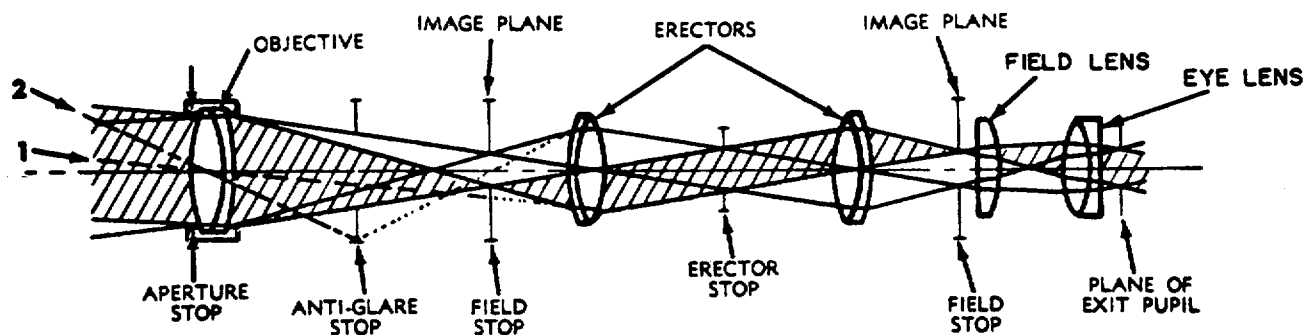

Figure 9-7. Diaphragm (Stop) Location in an Optical System

## 9-2. Optical Components - Continued

c. Filters (Colored). Filters (or ray filters) are colored glass disks with plane parallel surfaces. They are placed in the path of light through the optical system of a fire control instrument to reduce glare and light intensities. They are provided as separate elements (A, fig. 9-8) or mounted so they may be placed in or out of position as desired (B and C, fig. 9-8). Filters of various colors are used to improve visibility under different atmospheric and light conditions. Some of the more common colors of filters used are: smoke, yellow, amber, blue, red, and greenish-yellow.

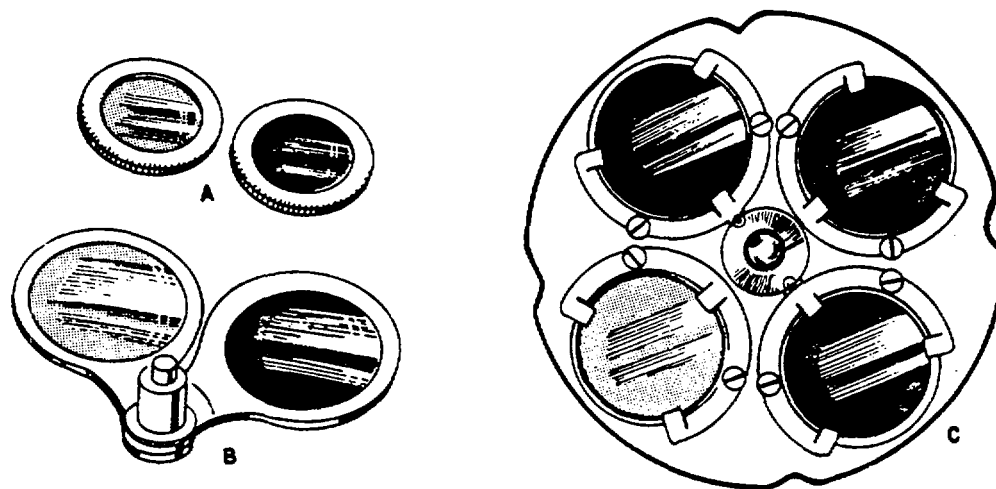

Figure 9-8. Types of Filter Mounting

- (1) The smoke (neutral) filter evenly reduces the intensity of light throughout the visible spectrum (used for observing against sun).
- (2) Yellow and amber filters are used to protect the eyes from glare reflected from objects being viewed; for example, the reflection of sunlight on water.
- (3) Amber and red filters are usually employed under various conditions of fog and ground haze. Red filters are also used to observe tracer fire.
- (4) Blue filters are helpful in detecting the outlines of camouflaged objects.
- (5) Greenish-yellow filters are intended to serve the purpose of both smoke and amber.

d. Filters (Polarizing). Polarizing filters, do not change the color of objects but merely decrease light intensity and eliminate glare. The substances used for polarizing filters can be considered as being made up of very minute parallel bars or grains. A polarizing substance, placed in the path of the light, permits only light waves that are parallel to the direction of the grain to pass through. Those light rays traveling at right angles to the bars or grain are blocked as shown in figure 9-9.

Change 2 9-6

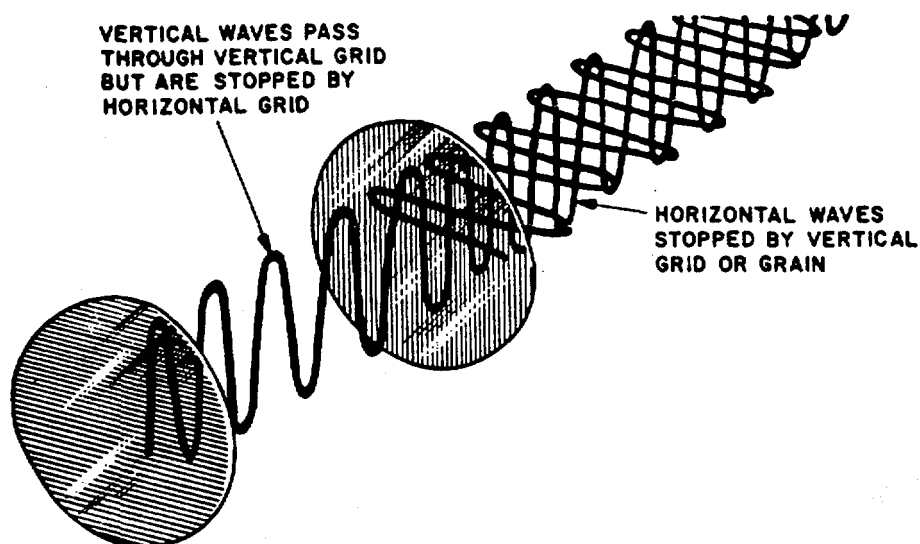

Figure 9-9. Principles of Light Polarization

e. Prisms. Optical prisms are blocks of glass, of many shapes, with two or more highly polished non-parallel flat surfaces that reflect or refract light, and which are especially designed and ground to perform various functions. They are used separately or in pairs to change the direction of light from a few seconds of arc (measuring wedge) or up to 360 degrees (Porro prism system).

- (1) The Amici or roof angle prism, as shown in figure 9-10 consists of a roof edge formed upon the long reflecting face of a right angle prism. It is used in elbow and panoramic telescopes to erect the image and bend the line-of-sight through a 90 degree angle.

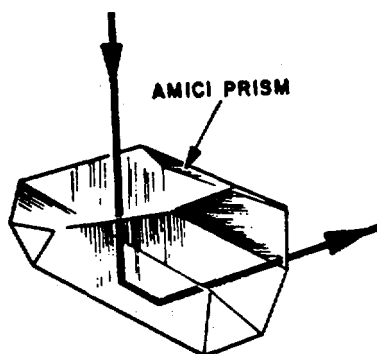
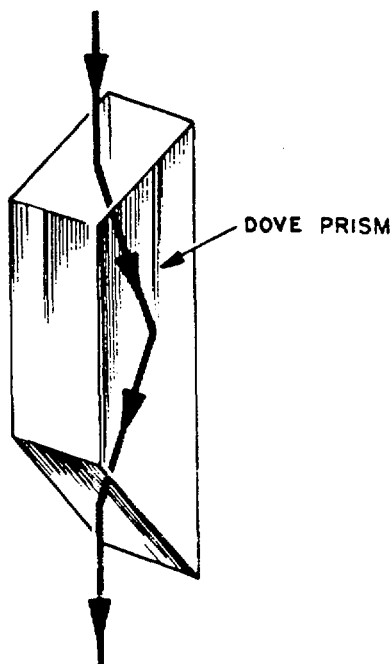

Figure 9-10. Amici Prism

**9-2. Optical Components - Continued**

- (2) Dove Prism. The Dove prism, as shown in figure 9-11, is used as a rotating prism in conventional types of optical systems of panoramic telescopes. When the prism is rotated about its longitudinal axis the image rotates in the same direction at double the angular speed.



*Figure 9-11. Dove Rotating Prism*

- (3) Porro Prism. A Porro prism is one of two identical prisms in a Porro prism system, as shown in figure 9-12. A Porro prism system, commonly used in binoculars is also used in erecting systems of other fire control instruments. The line-of-sight through a Porro prism system is displaced and bent 360 degrees, but it is not deviated.

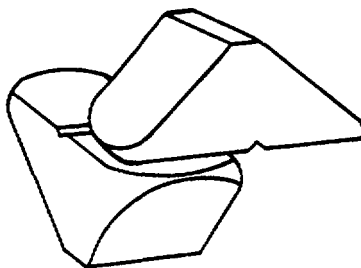

*Figure 9-12. Porro Prism Erecting System*

9-2. Optical Components - Continued

- (4) Penta Prism. A Penta prism, as shown in figure 9-13, is a five sided prism with two silvered surfaces. It is used to bend light rays through a constant angle, usually 90 degrees, without producing inversion or reversion if reflection takes place in the vertical or horizontal plane.

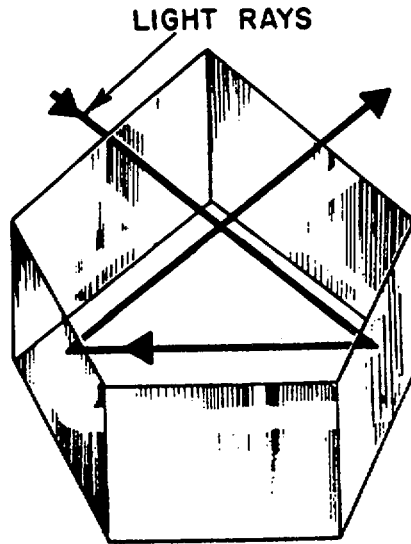

Figure 9-13. Penta Prism

- (5) Pechan Prism. A Pechan prism, as shown in figure 9-14, is a rotating pechan or Z prism consisting of two prisms separated at an angle to 45 degrees with two external reflecting surfaces that are silvered. This type of prism is used to invert the image in one plane without deviating or displacing the axis of the light rays. It is used in the conventional types of optical systems in panoramic telescopes.

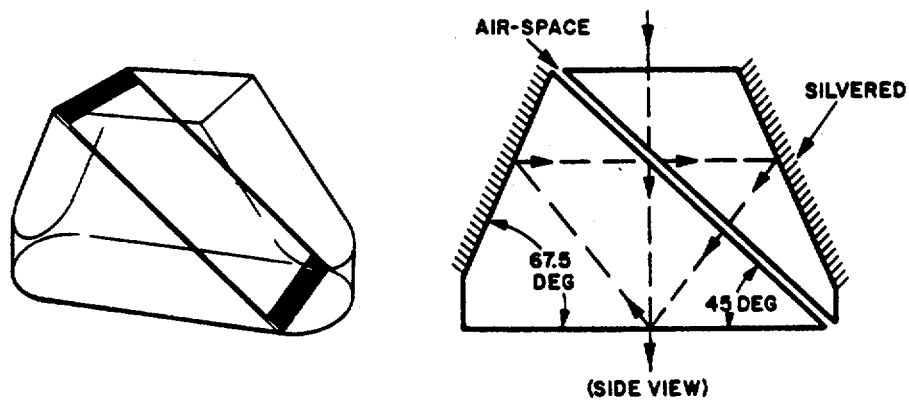

Figure 9-14. Pechan Prism

9-2. Optical Components - Continued

- (6) Right Angle Prism. A right angle prism will bend light rays through an angle of 90 degrees or 180 degrees depending on which reflecting surface is used (fig. 9-15). In basic panoramic optical systems it is normally used to reflect light rays through a 90 degree angle.

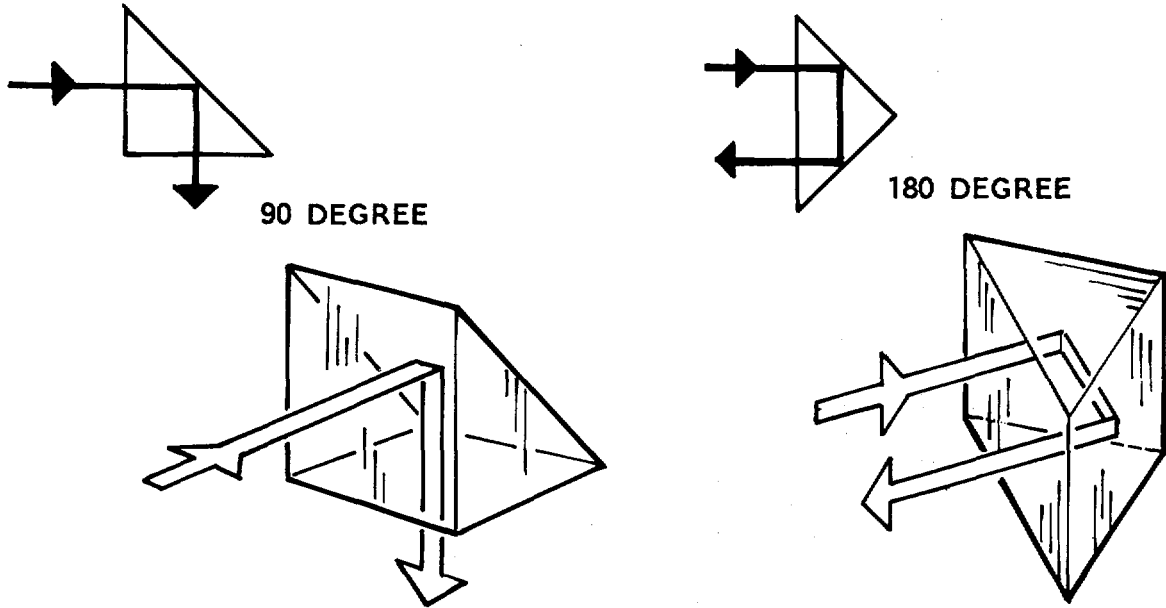

Figure 9-15. Right Angle Prism Showing Deflection of Light Rays

- (7) Wedge. Optical wedges used in fire control instruments are prisms with two plane surfaces at slight angles which divert the paths of light through small angles by refraction instead of by reflection (fig. 9-16). They are used where the angle of deviation required may be a matter of fractions of seconds and it would not be practical to produce such slight deviations by means of reflection surfaces. Wedges are used in measurement systems of range finders and to correct or adjust the alinement of paths of light.

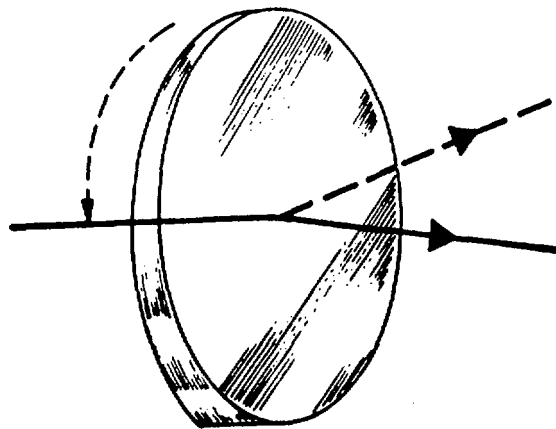

Figure 9-16. Light Deviations Through an Optical Wedge



9-2. Optical Components - Continued

f. Mirrors. Mirrors used to reflect the paths of light in fire control instruments are termed front surface mirrors. The silver coating, on the mirror, is put on the front of the glass instead of on the back of the glass like a common household mirror. Optical mirrors are sometimes used to reflect light rays in a manner which simulates the same effect that a prism would have in an optical system (fig. 9-17). Mirrors can also be used in the auto collimations of fire control test fixtures. Another form of optical mirror, known as a beam splitter (partial reflector) is a flat piece of glass lightly silvered so that some of the light rays will pass through the glass while others will be reflected off the silvered surface.

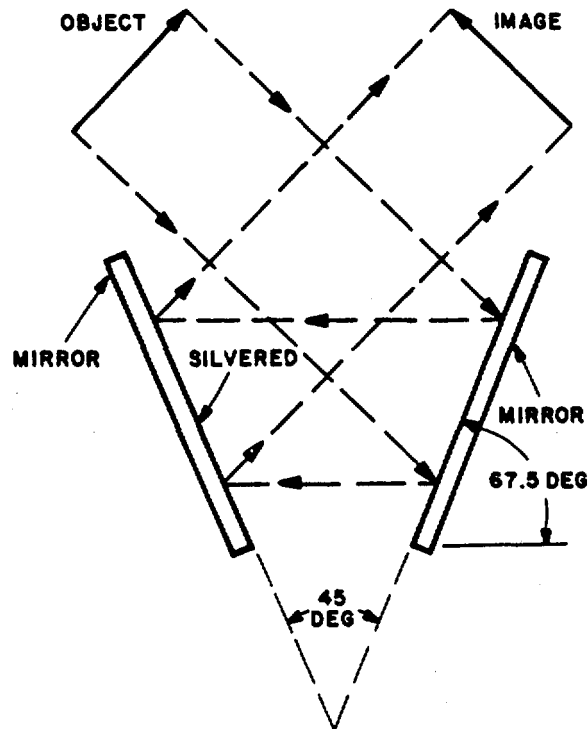

Figure 9-17. Using Mirrors to Simulate a Penta Prism

g. Reticles. Reticles are patterns placed in the focal plane of the objective for a fire control instrument which appear to the observer to be superimposed upon the field of view (fig. 9-18). They are used as a reference point when sighting and aiming for the purpose of calculating angular displacement and distance. Examples of some reticles used in fire control instruments are shown in (fig. 9-19).

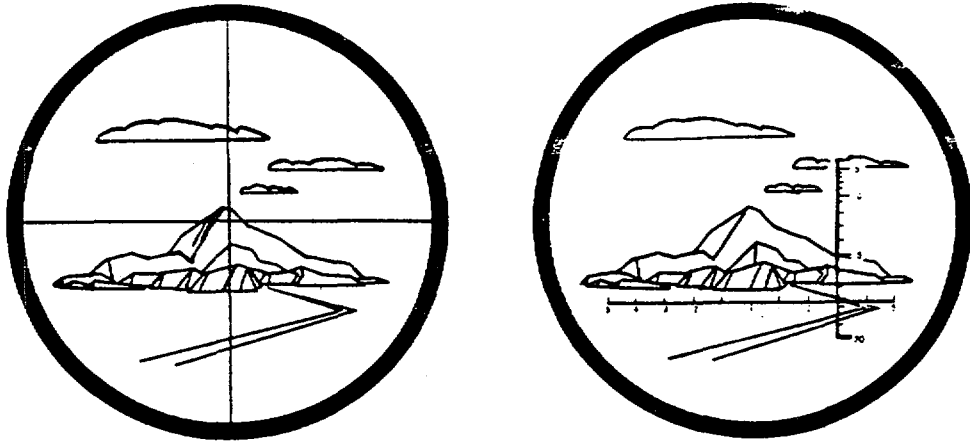

Figure 9-18. Reticle Patterns Superimposed on Field of View

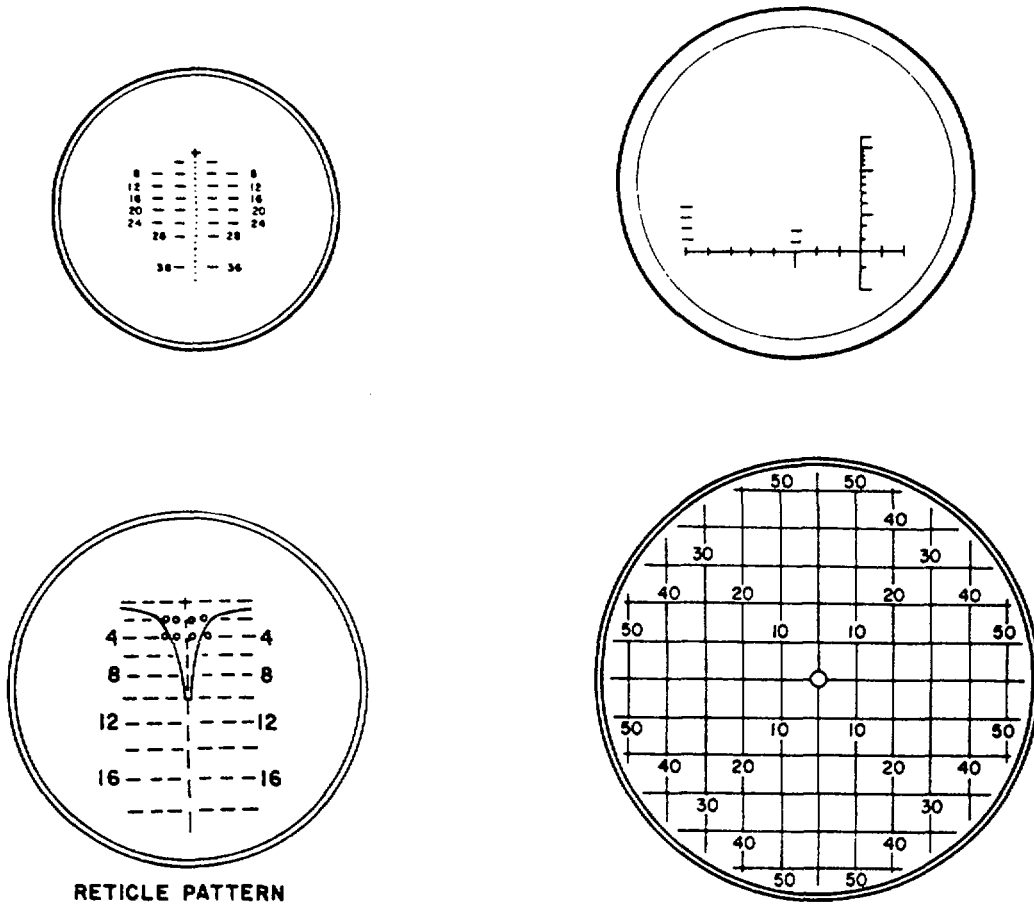

Figure 9-19. Types of Reticles Used in Fire Control Instruments

## Section II. GENERAL MAINTENANCE OF OPTICAL COMPONENTS

## 9-3. Cleaning Optical Components

a. Personal Cleanliness and Shop Neatness. Personal cleanliness is a great asset toward efficiency in the handling and cleaning of optical components. The hands should be washed frequently to keep them as free as possible of dirt and normal skin oil. Depot level optical shops are usually temperature and humidity controlled to provide the most ideal environment for working with optical components. If a controlled environment is not available, a well ventilated room located above the first floor of a building where there is a minimum of blowing dust is preferred. In the case of an instrument repair mobile van, the van should be located at a place remote from vehicular and personnel traffic. Ideal shop conditions are not always available, but in any shop the floor and benches should always be kept clean and the equipment maintained in an orderly fashion.

**CAUTION**

- **Lens cleaning compound may be used on externally exposed lenses of sealed instruments, such as the objective or eyepiece lens, and on lens removed from inside the instrument lens cells. This compound contains 70% water and if used on lenses while still in the cells the cleaner could seep around the lens and into the threads of the retaining rings thus leaving moisture in the instrument.**
- **When using acetone on coated optics, care should be exercised to prevent the removal of the coating from the lens surface.**
- **Acetone is detrimental to plastic. Do not clean plastic optical components with acetone.**

a. Cleaning Precautions. To minimize scratching and chipping during the cleaning process, optical components should never be jumbled together, allowed to lie unprotected on the work bench, or on the bottom of a cleaning tray. After optical components are removed from an optical system, they should always be wrapped in lens tissue for protection of the optical surfaces until they are ready to be cleaned by the repairperson. Care should be taken to keep the fingers from touching the polished surfaces of a component. Should you happen to touch a polished surface wipe off any fingerprints immediately with lens cleaner. The oil from the skin will deteriorate the coating on the component if not removed.

b. Cleaning Procedures. Cleaning optical components requires various types of lens cleaning agents, supplies, and equipment which are listed in table 9-1. Some of these materials may be obtained through the supply system, but some of the tools may have to be fabricated by the repairperson.

## 9-3. Cleaning Optical Components - Continued

Table 9-1. Special Tools and Supplies

Nomenclature	Description
Alcohol, denatured	0E760
Acetone, technical	
Lens tissue	7-1/2 X 11 inch sheets, NNN-P-40
Stainless steel pump dispenser	
Lens cleaning compound	Detergent solution, MIL-C-43454
Syringe	Bulb type, 6515-X29-3340
Artist brush	Number 6
Suction adapter	Fabricated, teflon or bakelite
Lens tongs	
Applicator	Fabricated, wood or fiberglass
Rapping stick	
Lens tray	

- (1) For initial cleaning of a component after removal from an instrument or lens cell, use a syringe or a camel hair brush to remove any dirt which may have fallen on the lens during removal. Then apply alcohol to a pad of cheesecloth or lens tissue and clean the component thoroughly. A light pressure should be applied to the surface of the component when cleaning. Using excessive pressure could possibly damage the coating or put scratches in the glass.
- (2) For final cleaning prior to installation of a lens in a cell or instrument, place the lens on a lens holder or a vacuum suction adapter (Fig. 9-20). Wrap a small piece of lens tissue around and over the end of a wood or fiberglass applicator (Fig. 9-21). Make sure you leave a cushioned tip over the end of the applicator so that it does not mar the lens surface. Moisten the lens tissue with acetone and proceed to clean the lens by rotating the applicator in a circular motion starting at the center of the lens and cleaning outward to the edge of the lens (Fig. 9-22). Repeat the above operation until the lens is free of dirt. Lift lens from suction adapter, clean the top of the adapter, turn lens over and repeat the cleaning operation on the other surface. Before inserting the lens in its cell be sure the cell has been cleaned of any sealant, washed in Dry Cleaning Solvent (exposed metal) or general purpose detergent (painted surface) and dried. Then properly orientate the lens and insert it into its cell. Hold the cell up to the light and visually inspect for dirt or lint. If dirt or lint is present on the lens, use vacuum with proper fabricated adapter (fig 9-23) or lens tissue to remove the contamination.

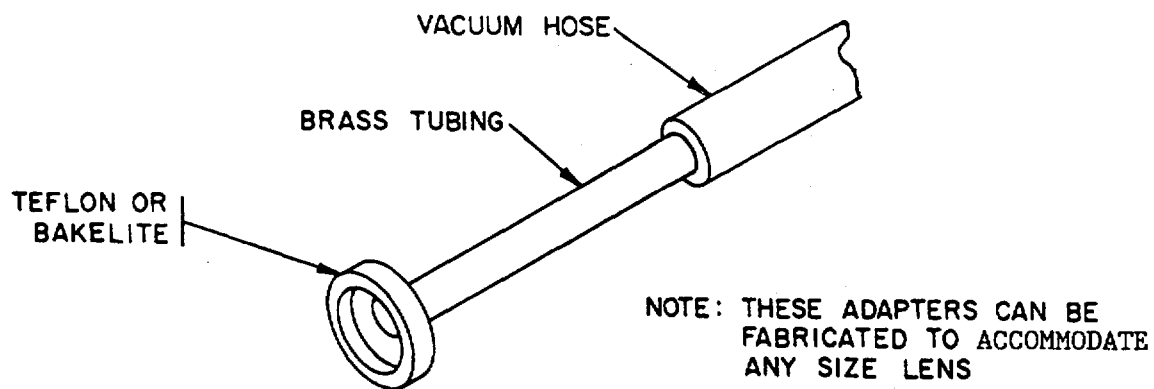

Figure 9-20. Vacuum Suction Adapter

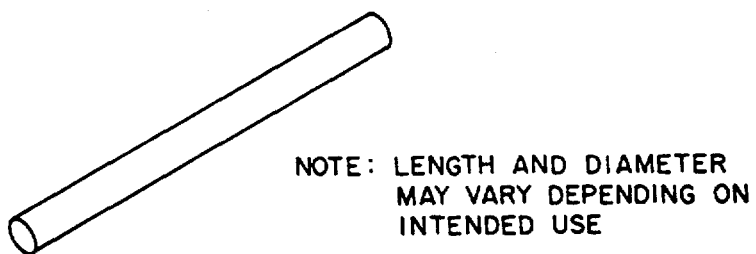

Figure 9-21. Wood or Fiberglass Applicator for Lens Tissue - Example

Change 2 9-15

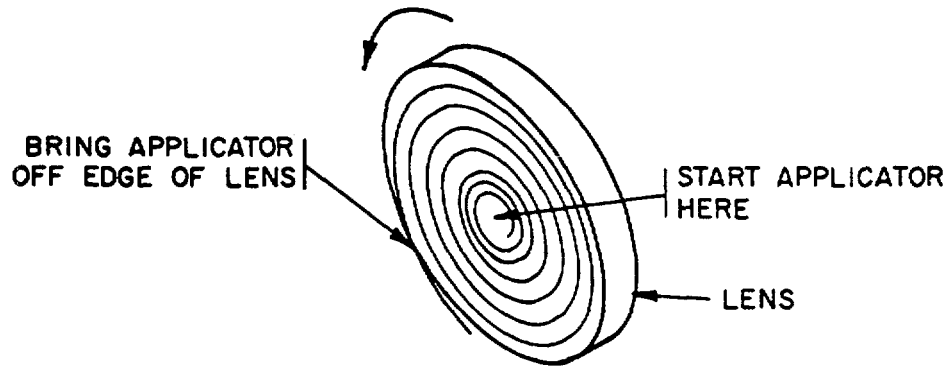

Figure 9-22. Path of Applicator When Cleaning a Lens

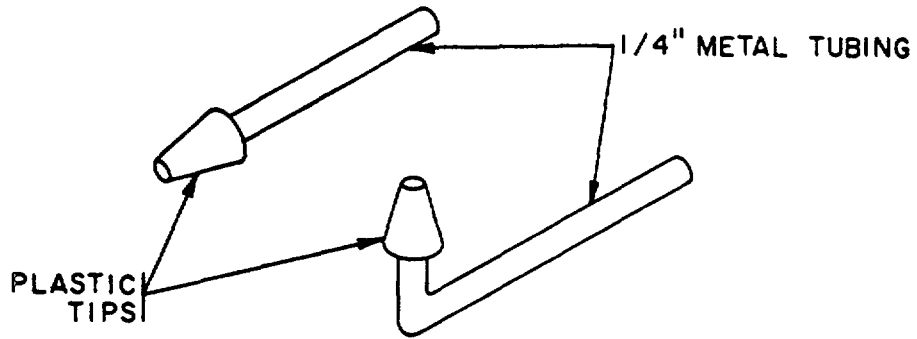

Figure 9-23. Straight and 90 Degree Vacuum Tips - Examples

### 9-3. Cleaning Optical Components - Continued

- (3) Lenses may also be cleaned without removing them from the cell. Cleaning the component is accomplished in the same manner as described in (2) above. Cleaning of the lens should start at its center and progress to its outer edge. Move the applicator to the edge of the lens cell and bring it off of the lens. Care must be taken to prevent leaving marks or streaks on the lens. Repeat this process on each side of the lens until it is free of dirt and lint.
- (4) Use of the syringe and the vacuum system are the most common methods for removing dirt and lint from the surfaces of lenses and lens cells. The syringe can be used in most cases, but it may just blow the dirt or lint off the lens and onto some other part of the cell or instrument. The vacuum system is the most efficient for dirt removal. A vacuum draws the dirt into the system and does not move the dirt around. Also, a suction adapter (fig. 9-24) can be used with a vacuum system to hold lenses for cleaning. A vacuum system should be supplied throughout the shop from a central pump with connections at each individual bench.

### 9-4. Storing and Handling Optical Components.

a. Care. Optical components should always be handled with extreme care. Components not handled properly may be damaged to an extent that necessitates regrinding, repolishing, or discarding the component completely.

b. Storing and Protecting Components. Optical components, whether new or used should be protected by keeping them in an out-of-the way place. A lens tray, with a felt lining on the bottom and a cover over it is a good way to keep components from being damaged. This also keeps excessive dust from settling on the components. Any time a component is not going to be used for a period of time, it should be wrapped in lens tissue and stored in a protective container.

c. Use of Holding Devices. In cleaning optical components it is sometimes necessary to use holding devices on small thin lenses or reticles. They should be held with lens tongs equipped with rubber protectors on the jaws to prevent chipping of the lens. In shops equipped with a central vacuum system, lenses may also be held with a suction cup adapter placed on a vacuum hose as shown in figure 9-24.

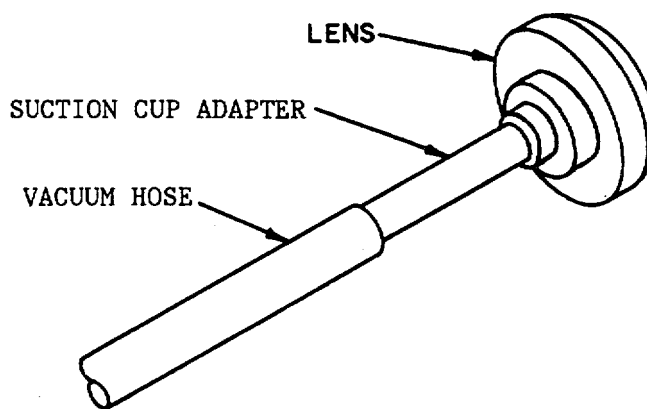

Figure 9-24. Suction Cup Adapter

## 9-5. Marking Optical Components.

a. Lenses. The primary purpose for marking lenses upon disassembly is to establish a reference, so the lenses can be assembled in their original positions in the instrument. This mark should consist of a V drawn on the unpolished surface (edge) across all the elements of a compound lens as shown in figure 9-25. The point of the V should be pointing towards the objective end of the instrument. All lenses of an instrument will be marked in this manner, thereby eliminating the possibility of assembling them incorrectly. The marking of lenses can usually be done with a pencil or a magic marker. In addition to the directional marking, the lenses will also be numbered to indicate the sequence in which they are placed in the instrument. For example: eye lenses should be marked 1, field lenses 2, first erector 3, and so on (fig. 9-25). The numbering system aids in preventing improper placement of the lenses which are similar in appearance and easily mistaken for each other. In some instruments, such as the binocular, the field lens has a very thin edge which is difficult to mark. In such cases it is necessary to note, when disassembling the instrument, whether the side of greater curvature faces the objective lens or the eye lens, and then assemble accordingly. It is also advantageous to draw a rough sketch of the optical system of the instrument being repaired, showing the position and relative curvature of all optical components. This may be done as each lens is removed from the optical system. When assembling the optical components, the sketch can be referred to for proper positioning, thus eliminating guesswork.

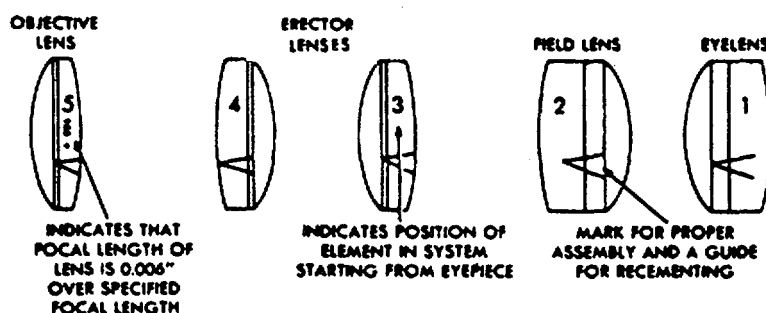

Figure 9-25. Lens Marking System

b. Prisms. All markings on prisms are placed on the unpolished surfaces. In marking prisms used individually, such as an amici or a right-angle prism, mark an arrow pointing toward the objective end of the instrument (fig. 9-26). The marking of prisms used in pairs (fig. 9-27) such as those in binoculars is a more complex process. These prisms have certain deviations and variations of light travel, and prism must first be marked to indicate whether it is located in the right or left telescope of the binocular. Identify such locations by placing an R or L on each prism. Immediately after the R or L mark and E or O. The E indicates that the prism is first in the light path of the eyepiece, whereas the O indicates that the prism is first in the light path of the objective lens. A prism marked LE belongs in the left telescope and is first in the light path of the eyepiece. To prevent the prisms from being assembled in a reversed position, an arrow should be drawn pointing toward the end of the prisms where they meet on the prism assembly.



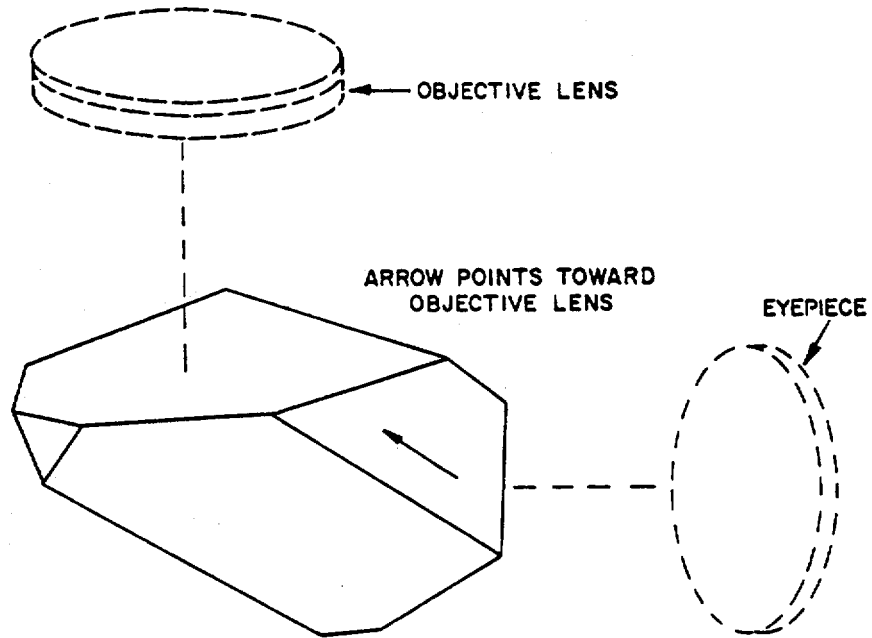

Figure 9-26. Marking a Single Prism

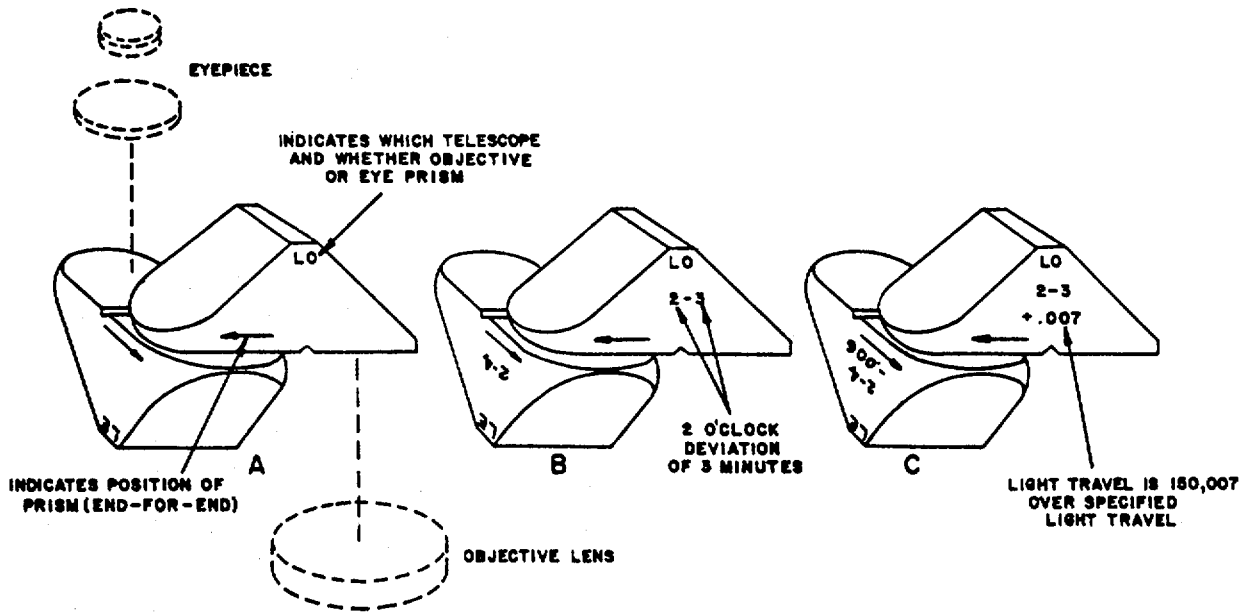

Figure 9-27. Marking Prism Pairs

## 9-5. Marking Optical Components - Continued

c. Marking Components for Light Travel and Deviation. The marking of components for light travel, deviation in prisms, and focal length in lenses is usually done by the manufacturer. To help the repair person understand what these markings represent, a brief description is as follows:

- (1) Variations in lenses from the intended focal length represents the only characteristic usually noted on a lens. The lens should be marked on its unpolished surface in a plus or minus thousandths of an inch, according to whether its focal length is longer or shorter than that desired or specified, as shown in figure 9-25.
- (2) In prisms, such as binocular prisms, the direction of deviation is indicated such as 2 o'clock, 5 o'clock, or 6 o'clock, followed by the amount of deviation such as 2 minutes, 3 minutes, or 4 minutes. For example a prism marked 5-3 indicates that the prism has a 3 minute deviation at 5 o'clock. Light travel, whatever the method used for its determination should be noted as plus or minus in relation to the ideal condition, and should be marked in thousandths of an inch such as .007 or .005 on the prism as shown in figure 9-27.

## 9-6. Inspecting Optical Components.

a. General Inspection. All optical components should be inspected by the repair- person for defects before they are installed in an optical system. All components will be inspected according to the criteria contained herein. Any component not meeting these standards must be reground and repolished. Should the defects of the component be extensive, the component should be discarded.

b. Definitions of Defects:

- (1) Chip. An indentation, usually irregular in shape, in a glass surface where a small piece of the glass surface has been chipped out, struck, or flaked off. A small crack which can be removed by honing.
- (2) Condensation (Moisture). Visible particles of water or visible staining due to the presence of water on the component.
- (3) Dig. A small, very short scratch in the glass surface. The size of the dig can be measured by comparison with the established dig standard.
- (4) Dirt. Visible particles or specks of foreign matter, such as dust, soil, paint flakes, and sand adhering to the glass surface.
- (5) Fingerprints. A visible impression upon the glass surface of the arches, loops, whirls, or composites of the fingertip(s).
- (6) Fractures. A crack or break on the exterior of the component and extending well into or all the way through the glass diameter or thickness.
- (7) Inclusions. A term used to denote the presence, within the body of the glass, of extraneous or foreign matter. Bubbles, for example, are a gaseous inclusion.
- (8) Lint. Particles of cloth or paper fibers adhering to the component surface or entrapped between the cemented component surfaces.

**9-6. Inspecting Optical Components - Continued**

- (9) Pit. A term denoting a small hole in the component surface, which can be seen as a small particle.
- (10) Scratches. Any marking or tearing of the component surface appearing as though it had been done by the sharp or rough edge of an instrument.
- (11) Cement Separation. This condition shows up as jagged lines and yellowish areas between the elements of a cemented lens.
- (12) Smears. The faint, but visible traces of cleaning solution left on the optical component when the cleaning procedure is improperly performed.

c. Inspection Requirements. The requirements herein shall apply to initial and in-process inspection of optical components.

**NOTE**

- **Information contained in tables 9-2 through 9-6 has been extracted from Maintenance Inspection Standard for Fire Control Materiel, MIS TOE 102 and Surface Quality Elements, part number 7641866.**
- **The combined length of maximum size scratches cannot exceed the maximum length as indicated in tables 9-2 through 9-6. This length is based upon the diameter of the lens.**
  - (1) Moisture and condensation. There will be no evidence of moisture, condensation, or staining resulting from moisture.
  - (2) Fractures. No fractures will be allowed on optical component surfaces.
  - (3) Smears or Fingerprints. There will be no evidence of any smears or fingerprints on optical component surfaces.
  - (4) Chips. The presence of chips on optical components will be permitted provided they are honed and do not extend more than 1/16 inch into the clear aperture of the component.
  - (5) Scratches. Scratches will be permitted provided the total effect of such discrepancies do not exceed that allowed in tables 9-2 through 9-6.
  - (6) Digs, Pits, and Bubbles. Digs, pits, and bubbles will be permitted in accordance with criteria given in tables 9-2 through 9-6.
  - (7) Coating. Coating with not more than 25% deterioration will be acceptable provided the deterioration is not concentrated in a given area. Crushes or rubs not heavily concentrated are permissible provided they do not extend into the clear aperture of the component.
  - (8) Cement Separation. Cement separation, once started, has a tendency to spread and therefore will not be permitted.

**9-6. Inspecting Optical Components - Continued**

- (9) Polished Surfaces. Polished optical surfaces will show no evidence of grayness or stains.
- (10) Reticles. The reticles will have no more than five pits, digs, or bubbles, no bigger than the smallest reticle line, over the entire surface of the reticle.

*Table 9-2. Prisms and Mirrors*

Estimated diameter	Number of scratches	Scratch size	Maximum length	Number of pits, digs, bubbles	Size of pits, digs, bubbles
up to 1.250	4	60	1/5	4	40
1.251 - 2.250	6	60	1/4	5	40
2.251 - up	8	60	5/16	6	40

*Table 9-3. Field Lenses \**

Estimated diameter	Number of scratches	Scratch size	Maximum length	Number of pits, digs, bubbles	Size of pits, digs, bubbles
up to 1.250	3	60	1/8	3	10
1.251 - 2.000	3	80	3/16	3	20
2.001 - up	3	80	1/4	3	40

\* Under no condition will scratches and pits, in the central area of the lens (25X of lens surface) be greater than that shown.

*Table 9-4. Eye Lenses*

Estimated diameter	Number of scratches	Scratch size	Maximum length	Number of pits, digs, bubbles	Size of pits, digs, bubbles
up to 1.250	3	60	1/8	3	20
1.251 - 2.000	5	60	3/16	5	20
2.001 - up	8	60	1/4	8	20

## 9-6. Inspecting Optical Components - Continued

Table 9-5. Objective, Erector Lenses and Windows

Estimated diameter	Number of scratches	Scratch size	Maximum length	Number of pits, digs, bubbles	Size of pits, digs, bubbles
up to 1.250	5	60	3/16	4	40
1.251 - 2.000	8	60	1/4	7	40
2.001 - up	10	60	5/16	10	40

Table 9-6. Reticles \*\*

Estimated diameter	Number of scratches	Scratch size	Maximum length	Number of pits, digs, bubbles	Size of pits, digs, bubbles
up to 1.250	3	60	1/8	3	10
1.251 - 2.000	3	80	3/16	3	20
2.001 - up	3	80	1/4	3	40

\*\* No scratches, pits, or lint will be permitted in central reticle pattern (etching) or in central area of field lens where it will be superimposed on reticle pattern.

## Section III. Reclamation of Optical Components

## NOTE

In the following processes (decementing, decoating, coating, and cementing of optical components) all lens halves, after being separated, should be kept together.

## 9-7. Decementing (Separating) Optical Components.

a. Reasons for Decementing. Lenses which are defective because of deterioration of the cement or the coating must be separated for repair.

b. Hot Plate Method of Decementing. This method of decementing incorporates the use of a hot plate placed inside an enclosed containment hood. The purpose of the containment hood is to reduce the amount of cooler room air coming in contact with the heated lens, causing it to fracture. The procedure for decementing with this method is as follows:

- (1) Place a fiberglass cloth over the hot plate heating surface, to protect the lens surface from damage, and preheat the hot plate to 350 to 450 degrees Fahrenheit.

**9-7. Decementing (Separating) Optical Components - Continued**

- (2) Place the lens or lenses to be decemented on the hot plate for 1 to 5 minutes. A slight cracking noise may be heard when the thermal expansion of the lens breaks the cement bond, also the cement will become visible between the lens elements.
- (3) With a pair of lens tongs, carefully remove the lens from the hot plate and place it on a piece of cardboard padded with cheesecloth.
- (4) To separate the lens elements position the lens on its edge. With a sharp knife apply pressure between the two lens elements.
- (5) If the lens does not separate, place it back on the hot plate for an additional 1 to 3 minutes, and repeat steps (3) and (4) above.

c. Vacuum Oven Method. This method of decementing lenses is more involved than the hot plate method of decementing and is used primarily to separate large lenses that would fracture when placed on a hot plate. This method allows the lenses to be heated and cooled slowly in an air free atmosphere thus reducing the possibility of fracturing. The procedure for decementing with this method is as follows:

- (1) Place the lenses in vacuum oven on shelves that are lined with fiberglass cloth.
- (2) Set the oven to a temperature of 350 to 450 degrees Fahrenheit and pump the air out of the oven. Heat the lenses at this temperature for 24 to 36 hours.

**NOTE**

**If oven is not equipped with a thermostat graduated in degrees Fahrenheit, place a thermometer inside the oven so it can be viewed through the front window and adjust the temperature accordingly.**

- (3) Turn off the oven and let the lenses cool to room temperature before releasing the vacuum in the oven and removing the lenses.
- (4) Place the lenses on a piece of cardboard padded with cheesecloth.
- (5) To separate the lens elements, position them on edge and use a sharp knife to apply pressure between the two elements.
- (6) If lenses do not separate, repeat steps (1) through (5) above.

d. Removing Cement from Lens Elements. After separating the lens elements, perform the following procedures to remove the cement.

**NOTE**

**This procedure only applies to lenses that do not require recoating.**

- (1) Soak the lens elements in a bath of acetone for approximately 15 minutes.
- (2) Remove the cement from the lens elements with a piece of cotton. If all the cement cannot be removed repeat step (1) above.

**9-8. Decoating Optical Components.****WARNING**

- **Sulfuric and boric acids are highly corrosive and react quickly on the skin and clothes. Repair persons should wear rubber gloves, rubber aprons, and goggles. A safety shower or other means should be provided for quick washing in case of an accident.**
- **The decoating process should be carried out under a ventilated hood, which will draw off any corrosive vapors.**
- a. Procedures for Decoating.
  - (1) Mix a solution of 5 grams boric acid crystals in 150 cubic centimeters of concentrated sulfuric acid.
  - (2) Place lens elements in a pyrex baking dish lined with a fiberglass cloth.
  - (3) Insure that the acid solution and the lens elements are both at room temperature. Carefully pour a sufficient amount of the acid solution into the pyrex dish to completely cover the lens elements.
  - (4) Place a glass thermometer in the acid solution to monitor the temperature. Position the dish on a hot plate, under a ventilation hood, and heat to a temperature between 230 and 250 degrees Fahrenheit.
  - (5) After approximately 30 minutes, turn the hot plate off and allow the acid solution and lenses to cool.
  - (6) When the acid solution has cooled to room temperature, use a battery acid syringe to transfer the acid from the dish into a suitable storage container. This acid solution can be reused until it becomes too weak to remove the coating from the elements.
  - (7) Remove the lenses individually from the pyrex dish, wash them in luke-warm water, and dry with cheesecloth.
  - (8) After drying the lens elements, they should be checked for defects. Should any defect be found the lens element should be marked with a wax pencil and sent to be reground or repolished.

**9-9. Coating Optical Components.**

a. Reasons for Coating. The principle reason for coating optical components of fire control instruments is to increase light transmission, resulting in better visibility of the target. The coating will also reduce haze and ghost images caused by internal reflection in the instrument.

**9-9. Coating Optical Components - Continued****NOTE**

**Coating is a thin film of magnesium fluoride applied to the surface of optical elements at a thickness of one-quarter wavelength of light (550 to 600 millimicrons).**

b. Identifying Coated Optics. To identify coated optical elements, hold the element at an angle to a light source. Observe the reflection of the light source on the surface of the lens. The reflection of the light will have a purplish or bluish-purple tint if the element is coated properly.

c. Preparation for Coating. The procedure for cleaning optical elements is as follows:

- (1) Mix a solution of 1/2 teaspoon of Duponol Me Dry and 1 quart of luke-warm water in a stainless steel tray. Place a pad of cheesecloth in the bottom of the tray to protect element surfaces.
- (2) Carefully place lens elements in the tray and allow to soak from 1 to 2 minutes. Then wash each lens element with a piece of cheesecloth in the cleaning solution.
- (3) Remove one element at a time and dry the element with a piece of cheesecloth (fig. 9-28). Inspect element for foreign matter such as dirt and lint. If the element is not clean repeat steps (1) through (3) above.
- (4) Place clean lens elements on holding fixture as described in paragraph d.



*Figure 9-28. Proper Method of Holding a Lens*

d. Holding Fixture Setup (fig. 9-29). The holding fixture is designed with adjustable rails to hold any size or shape of optical element. The procedure for setting up the fixture is as follows:



## 9-9. Coating Optical Components - Continued

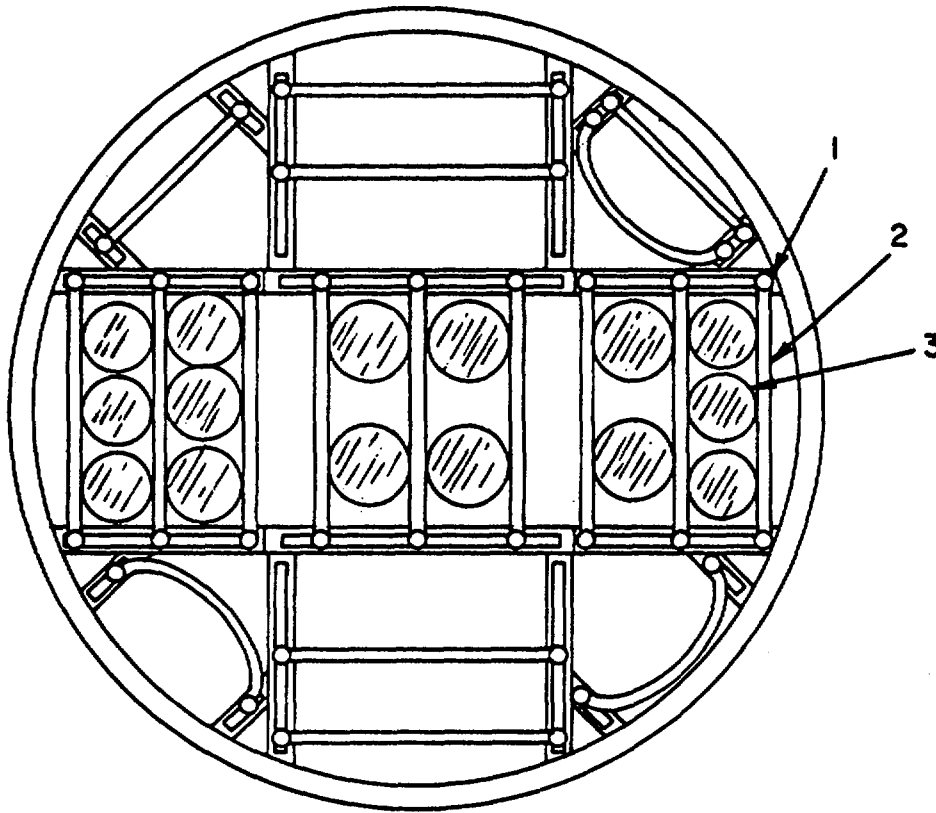

Figure 9-29. Holding Fixture

**CAUTION**

Never wedge the elements tightly into the holding fixture rails. Allow a small amount of clearance between the elements and the rails for expansion during the coating process. This will prevent chipping or cracking of the elements.

- (1) Loosen rail screws (1) and position rails (2) to the desired spacing.
- (2) Position lens elements (3) on rails (2) allowing a small amount of clearance between elements and rails.
- (3) Tighten rail screws (1).

**NOTE**

If the coating process is not performed immediately, cover the holding fixture and lens elements with batiste cloth to prevent dust and dirt from contaminating the elements.

Change 2 9-27

**9-9. Coating Optical Components - Continued**

e. The Coating Unit (fig. 9-30). This is a high vacuum machine that must have the capabilities of evaporating magnesium fluoride and be able to produce a vacuum of  $5 \times 10^5$  mm of mercury. Refer to the manufacturer's manual for the proper maintenance and operating procedure of the vacuum unit.

f. Coating Procedures (fig. 9-30). The following is a procedure for coating lenses in a high vacuum coating unit.

**CAUTION**

**Before attempting to raise bell jar, all vacuum must be released from system. Failure to release vacuum will damage bell jar.**

- (1) Open SYS VENT valve (17) to release vacuum from bell jar (1).
- (2) Place MAIN PWR switch (15) and AUX PWR switch (10) to the ON position.

**CAUTION**

**Do not attempt to change position of the hoist switch while raising or lowering the bell jar. Changing the position of the hoist switch while bell jar is in motion will damage the hoist.**

- (3) Raise bell jar by setting the HOIST switch (22) to the UP position.

**NOTE**

**Steps (4) through (7) refer to figure 9-31.**

- (4) Place holding fixture (fig. 9-29) on support ring (4). Position holding fixture cover (2) on support ring (4).
- (5) Fill crucible (7), level full, with magnesium fluoride and position on turntable (6).

**CAUTION**

**Do not allow filament to come in contact with the magnesium fluoride. This will prevent spattering which will cause damage to the lens components.**

- (6) Adjust turntable (6) to position crucible (7) 1/8 inch from filament (8). Position spatter shield lever (21, fig. 9-30) to the right.
- (7) Remove dust and dirt from baseplate (5) and turntable (6) with a watchmaker's blower.

**Change 2 9-28**

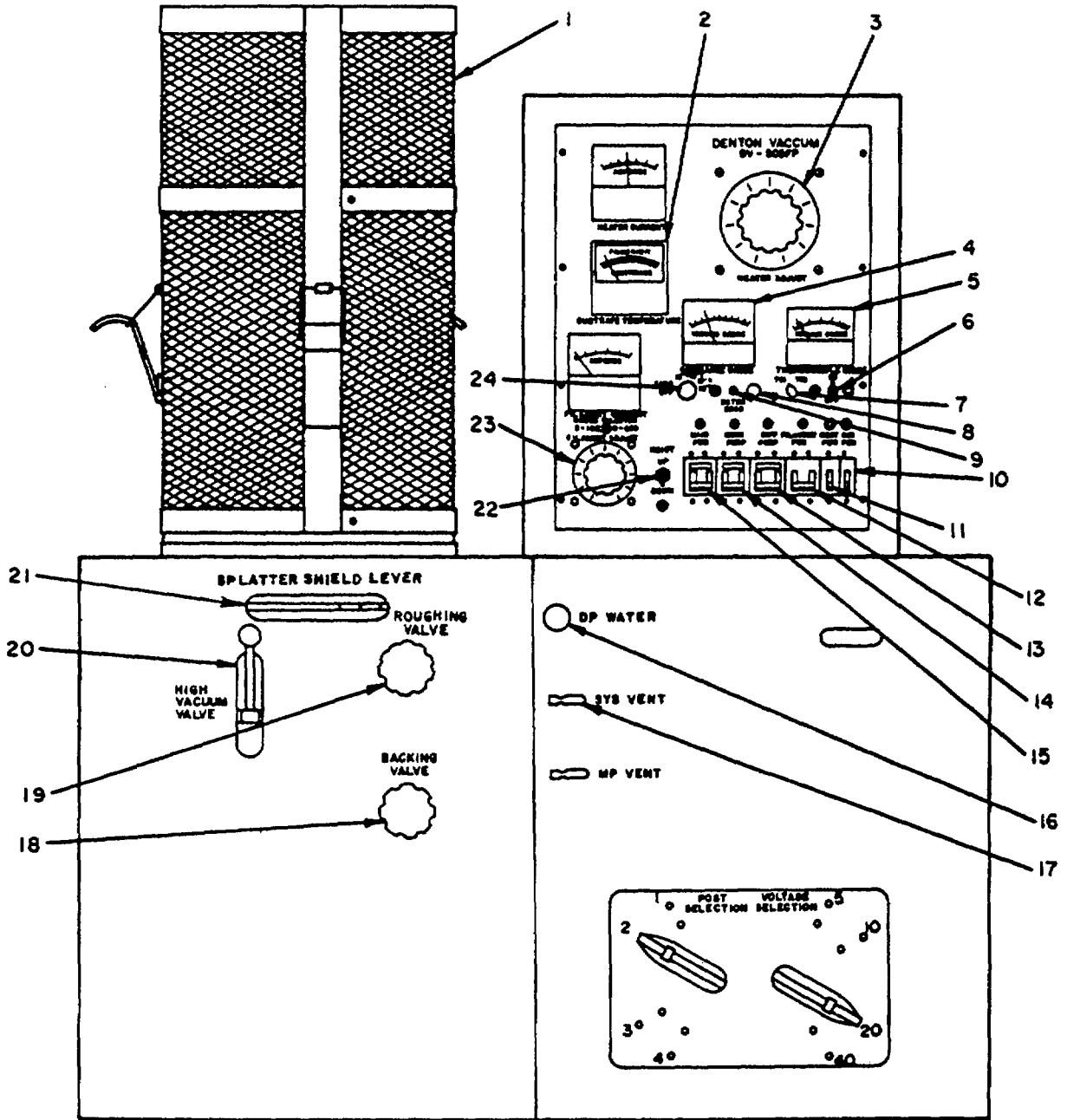

Figure 9-30. Optical Coating Unit

**9-9. Coating Optical Components - Continued**

KEY to figure 9-30:

- |  |   |
|--|---|
| 1. Bell jar                              | 13. DIFF PUMP (Diffusion pump) switch     |
| 2. SUBSTRATE TEMPERATURE GAUGE           | 14. MECH PUMP (Mechanical pump) switch    |
| 3. HEATER ADJUST knob                    | 15. MAIN PWR (Main power) switch          |
| 4. DISCHARGE GAUGE                       | 16. DP WATER (Diffusion pump water) valve |
| 5. THERMOCOUPLE GAUGE                    | 17. SYS VENT (System vent) valve          |
| 6. THERMOCOUPLE GAUGE switch             | 18. BACKING VALVE                         |
| 7. THERMOCOUPLE switch                   | 19. ROUGHING VALVE                        |
| 8. ZERO SET knob                         | 20. HIGH VACUUM VALVE                     |
| 9. METER READ switch                     | 21. Splatter shield lever                 |
| 10. AUX. PWR (Auxiliary power) switch    | 22. HOIST switch                          |
| 11. HEATER PWR (Heater power) switch     | 23. FILAMENT ADJUST knob                  |
| 12. FILAMENT PWR (Filament power) switch | 24. Range selector switch                 |

(8) Place HOIST switch (22) in the DOWN position to lower bell jar (1) onto the baseplate (5, fig. 9-31).

(9) Rotate HEATER ADJUST knob (3) to approximately mid-range.

**NOTE**

**Allow mechanical pump a 5 to 10-minute warm-up period after power has been applied.**

(10) Set MECH PUMP switch (14) to the ON position and close SYS VENT valve (17).

(11) Place THERMOCOUPLE GAUGE switch (6) to the ON position and THERMOCOUPLE switch (7) to the TC1 position.

**NOTE**

**THERMOCOUPLE GAUGE (5) should indicate approximately 50 microns before proceeding to next step.**

(12) Rotate BACKING VALVE (18) fully counterclockwise to the open position. This will evacuate the diffusion pump and the lower vacuum chamber.

**NOTE**

**THERMOCOUPLE GAUGE (5) should indicate approximately 50 microns before proceeding to next step.**

(13) Rotate BACKING VALVE (18) fully clockwise to the closed position. Rotate ROUGHING VALVE (19) fully counterclockwise to the open position. This will evacuate the bell jar (1).

**NOTE**

**THERMOCOUPLE GAUGE (5) should indicate approximately 50 microns before proceeding to next step.**

(14) Rotate ROUGHING VALVE (19) fully clockwise to the closed position. Rotate BACKING VALVE (18) fully counterclockwise to the open position.

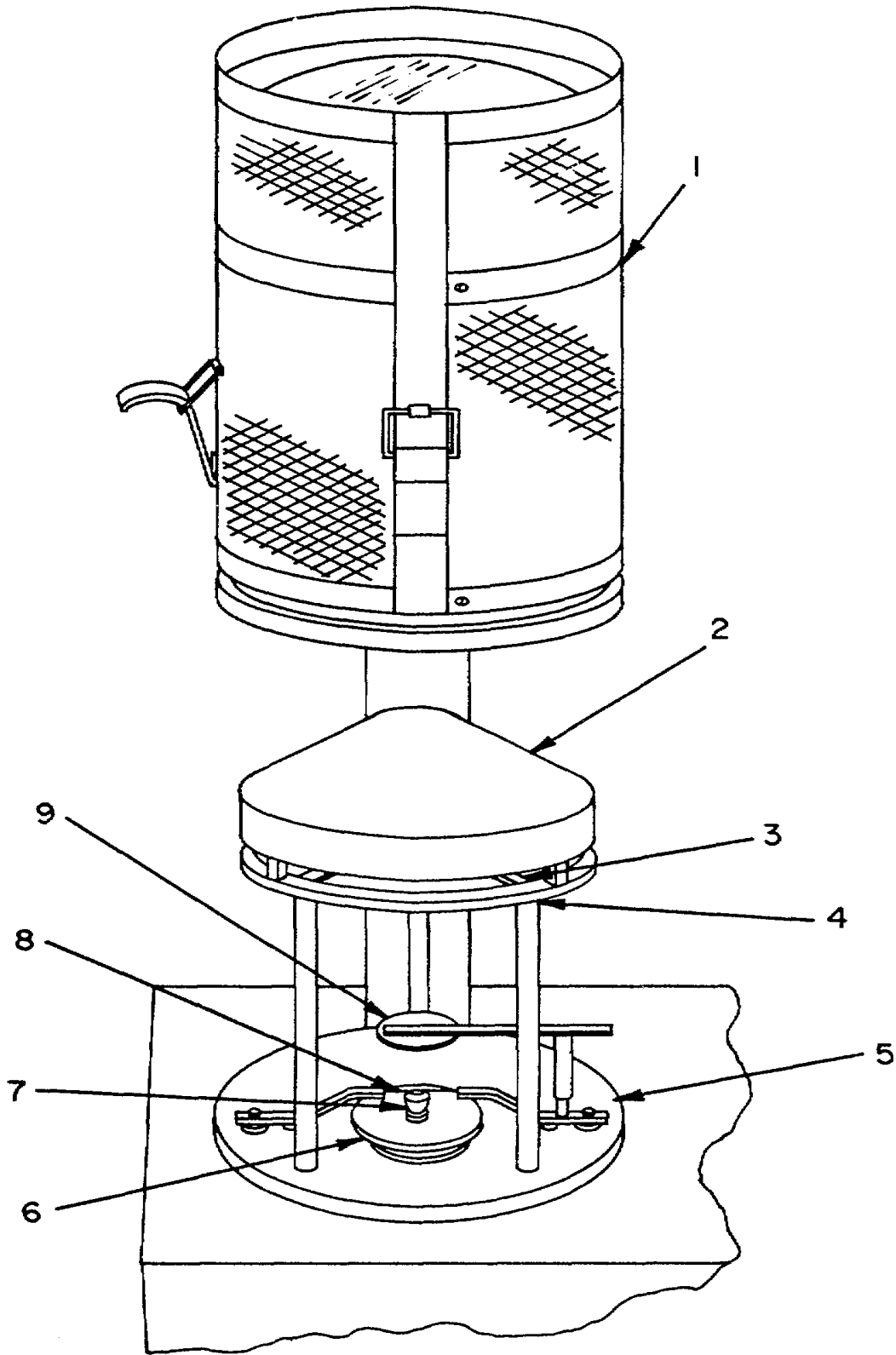

Figure 9-31. Optical Coating Unit - With Holding Fixture Installed

**9-9. Coating Optical Components - Continued**

KEY to figure 9-31:

- |                          |                         |
|--------------------------|-------------------------|
| 1. Bell jar              | 6. Adjustable turntable |
| 2. Holding fixture cover | 7. Crucible             |
| 3. Holding fixture       | 8. Filament             |
| 4. Support ring          | 9. Splatter shield      |
| 5. Baseplate             |                         |

**CAUTION**

**Allow approximately 12 minutes for the diffusion pump to reach operating temperature after the power has been applied. This will prevent internal damage to the diffusion pump.**

(15) Turn DP WATER valve (16) fully counterclockwise and place DIFF PUMP switch (13) to the ON position.

(16) Turn BACKING VALVE (18) fully clockwise to the closed position. Turn ROUGHING VALVE (19) fully counterclockwise to the open position.

**NOTE**

**THERMOCOUPLE GAUGE (5) should indicate approximately 50 microns before proceeding to next step.**

(17) Rotate ROUGHING VALVE (19) fully clockwise to the closed position. Rotate BACKING VALVE (18) fully counterclockwise to the open position. Set THERMOCOUPLE switch (7) to the TC 2 position and place HIGH VACUUM VALVE (20) to the up position.

**NOTE**

- **Coating can not be applied to lens elements until SUBSTRATE TEMPERATURE GAUGE indicates a temperature of at least 400 degrees Fahrenheit.**
- **If indication on SUBSTRATE TEMPERATURE GAUGE exceeds 450 degrees Fahrenheit, adjust the HEATER ADJUST knob counterclockwise to reduce temperature.**

(18) Place HEATER PWR switch (11) to the ON position and rotate the HEATER ADJUST knob (3) fully clockwise. Monitor SUBSTRATE TEMPERATURE GAUGE (2) for an indication of not less than 400 degrees Fahrenheit and not more than 450 degrees Fahrenheit.

(19) Place range selector switch (24) to the ZERO position.

**NOTE**

**Allow 30 seconds for cold cathode tube to reach operating temperature before proceeding to next step.**

**9-9. Coating Optical Components - Continued**

- (20) Press and release METER READ switch (9) then adjust ZERO SET knob (8) for 0 indication on DISCHARGE GAUGE (4).
- (21) Place range selector switch (24) to the  $10^{-4}$  position. If indication on DISCHARGE GAUGE (4) is above 1, let unit pump down until indication of 1 or less than 1 is obtained.
- (22) Place range selector switch (24) to the  $10^{-5}$  position and monitor DISCHARGE GAUGE (4) for an indication of 5 or less.

**NOTE**

**Do not proceed to step (23) until the SUBSTRATE TEMPERATURE GAUGE (2) indicates a temperature of not less than 400 degrees Fahrenheit and the DISCHARGE GAUGE (4) indicates 5 or less.**

- (23) Rotate FILAMENT ADJUST knob (23) fully counterclockwise and set FILAMENT PWR switch (12) to the ON position.

**WARNING**

**To prevent injury to the eyes, always wear welding-type goggles when observing filament for spattering.**

- (24) While observing filament (8, fig. 9-31) slowly rotate the FILAMENT ADJUST knob (23) clockwise until spattering occurs. Then slowly rotate FILAMENT ADJUST knob counterclockwise until spattering stops.

**NOTE**

**During the coating process, observe the reflection of the heat lamps on the lens elements. The lens elements will change colors as the thickness of the coating increases. The desired thickness of coating has been obtained when the reflection on the lens elements turns purple to bluish-purple in color. (550 to 600 millimicrons).**

- (25) Start the coating process by positioning the spatter shield lever (21) to the left.
- (26) When the desired thickness of coating is obtained, the coating process is stopped by positioning the spatter shield lever (21) to the right.
- (27) Rotate FILAMENT ADJUST knob (23) fully counterclockwise and turn FILAMENT PWR switch (12) to the OFF position.
- (28) Rotate HEATER ADJUST knob (3) fully counterclockwise and turn range selector switch (24) to the OFF position.

**9-9. Coating Optical Components - Continued**

- (29) Monitor SUBSTRATE TEMPERATURE GAUGE (2) until a temperature of approximately 200 degrees Fahrenheit is obtained and then open SYS VENT valve (17) to release vacuum from bell jar (1).
- (30) Place HOIST switch (22) in the UP position and allow bell jar (1) to raise completely.

**WARNING**

**Protective gloves should be worn to prevent burn injuries when removing items from the bell jar.**

- (31) Remove holding fixture cover (2, fig. 9-31) from support ring (4, fig. 9-31) and cover lens elements with batiste cloth.
- (32) Remove holding fixture (3, fig. 9-31) from support ring (4, fig. 9-31) and place on a table to cool.
- (33) Place HOIST switch (22) in the DOWN position and lower bell jar (1) completely.

**9-10. Cementing Optical Components.****WARNING**

**Use adhesives in a well ventilated area away from open flames. Adhesives are harmful to skin and clothing, can burn easily, and may give off harmful vapor.**

a. Preparing the Cement. Optical cement is a thermosetting cement consisting of two parts, a polymerizable resin mixture and a catalyst. Using an eye dropper mix 100 parts of HE-80, part A with 1 part of HE-80, part B into a glass bottle. Using the eye dropper mix the two parts thoroughly.

b. Cementing.

- (1) Remove matching set of lens elements from coating rack and remove all traces of dust and lint using a watchmaker's blower. If dust and lint cannot be removed by this method, clean the elements with acetone and lens cleaning tissue.
- (2) Place the concave element on a piece of black felt paper with the concave surface up.
- (3) Apply optical cement to the center of the lens surface with an eyedropper. The amount of cement needed will vary with the size of lens. Usually only a few drops of cement are required.
- (4) Make sure the matching convex element is clean and position it on the concave element. Apply a light downward pressure to spread the cement evenly between the elements.



**9-10. Cementing Optical Components - Continued**

- (5) Using a cork stopper, move the top convex element in a slight circular motion to remove any air bubbles that may have formed in the cement. This also removes excess cement from between the lens elements.
- (6) Remove excess cement by wiping the edge of the lens elements with a piece of batiste cloth dampened with acetone.

**CAUTION**

**Position a piece of plate glass over the top of the surface plate to prevent the lens elements from becoming scratched during the alinement process.**

**NOTE**

**The surface plate and plate glass covering used in step (7) below, must be leveled to prevent the lens elements from shifting during the alinement process.**

- (7) Position the lens elements on top of a leveled surface plate.
- (8) Aline the lens elements by positioning two V-blocks, the open jaws of the V-blocks facing each other, against the outer edges of the lens elements.
- (9) Using the V-blocks, apply a slight pressure to the edge of the lens elements to aline the edges flush with each other.

**CAUTION**

**Keep oven doors closed during the baking process to prevent the lenses from being exposed to cool air which could cause separation of the lens elements.**

**NOTE**

- **Allow cement to harden for a period of 3 to 5 hours before attempting to move the lens elements.**
  - **Baking oven must be level to prevent any shifting of the two lens elements.**
- (10) Remove the glass plate with lenses from the surface plate and place in the baking oven. Bake lenses at a temperature of 170 to 180 degrees Fahrenheit for a period of 4 to 6 hours. When baking time is completed, turn oven off and allow lenses to cool slowly to room temperature.
  - (11) After lenses have cooled, remove them from the oven and clean off any excess cement from edge of the lens with a sharp knife or razor blade.
  - (12) Thoroughly clean lens to remove all cement residue, dirt, and lint.
  - (13) Inspect for any defects resulting from the cementing process, such as dirt, lint, separation, or air bubbles between the lenses. Any lens having defects and not meeting the inspection requirements of paragraph 9-6 will have to be separated and recemented.

## CHAPTER 10

## FIRE CONTROL TEST EQUIPMENT

## Section I. OPTICAL TEST INSTRUMENTS

## 10-1. Scope.

The optical test instruments listed in this section are those most commonly used in the rebuild and inspection of fire control instruments. The test instruments are usually used in conjunction with test fixtures, V-blocks, and holding devices.

## 10-2. Projector Collimator.

a. Description. The projector collimator (fig. 10-1) is an optical device similar to an ordinary straight tube telescope except that it does not have an erecting system. The eyepiece is designed and machined to accommodate a lamp housing, which has a clamping screw so that it may be secured to the collimator. The lamp housing is equipped with a lamp assembly which provides illumination for the collimator. The collimator contains a reticle (fig. 10-2). The reticle pattern is graduated in mils and a 1 mil square at the center is provided so that any adjustment or inspection necessitating 1/2 mil tolerance can be accurately made. Smaller tolerances can be easily estimated. Resolution marks on the reticle are provided as an aid when checking definition of the instruments optical system. The objective end of the projector collimator is adjustable and has an objective scale graduated with an infinity mark and four other marks representing 75, 100, 200, and 500 yards, so the objective can be accurately positioned, setting the projector collimator at the correct parallax distance.

b. Use. The projector collimator serves as a testing target when used with various test fixtures for collimation and final inspection of fire control sighting instruments. The collimator is also used for checking definition of field-of-view, parallax, reticle plumb, and reticle accuracy.

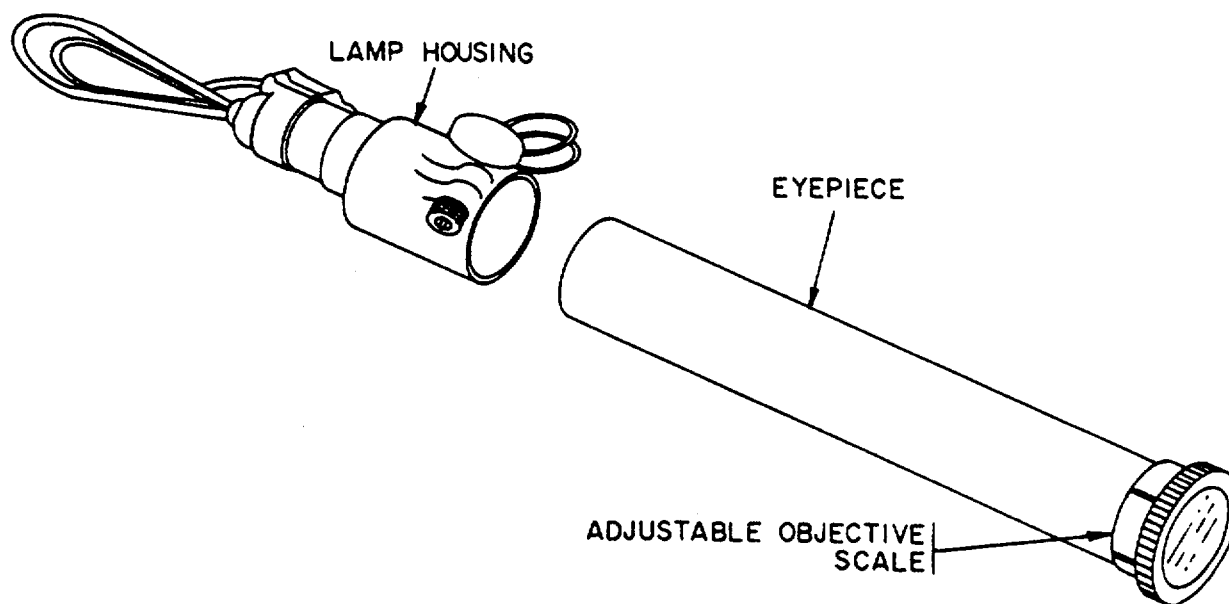

Figure 10-1. Project Collimator.

## 10-2. Projector Collimator - Continued

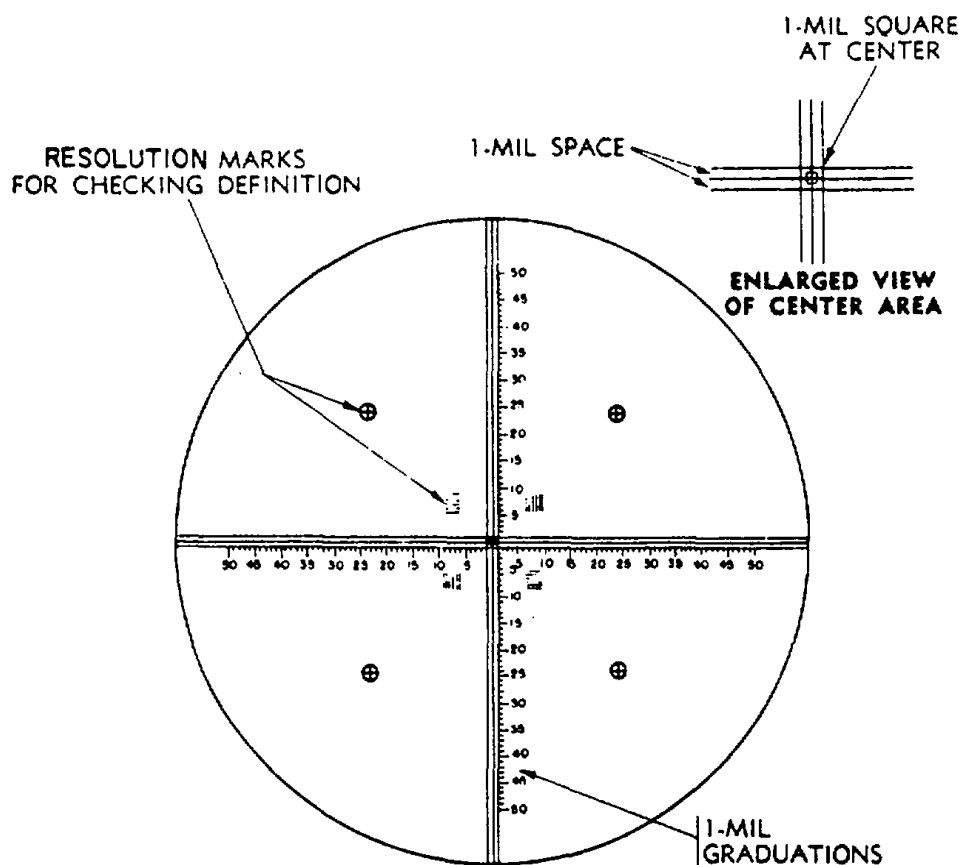

Figure 10-2. Projector Collimator Reticle

## 10-3. Collimating Telescope.

a. Description. The collimating telescope (fig. 10-3) is a small straight tube telescope containing an objective lens, a reticle, and an eyelens. The outside surface of the telescope is carefully machined so that its optical and mechanical axes may be aligned. The telescope contains no erecting system, so when viewing through the telescope, a reverted, inverted image is seen upside down, with the right side on the left.

b. Use. The collimating telescope can be used to establish a horizontal or vertical line by means of its own reticle to test instruments for field-of-view tilt, reticle tilt, and diopter scales adjustments. It may also be used in the setup and alinement of fire control test fixtures.

## 10-4. Diptometer.

a. Description. The diptometer (fig. 10-4) is a calibrated collimating telescope. It has a conventional type focusing eyepiece with an attached diopter scale, a stationary reticle pattern consisting of two lines crossing each other at right angles, and adjustable objective with a diopter scale and attached index. The eyepiece diopter scale ranges from +4 to -4 diopters and the objective scale is graduated from +1 to -1 diopter.

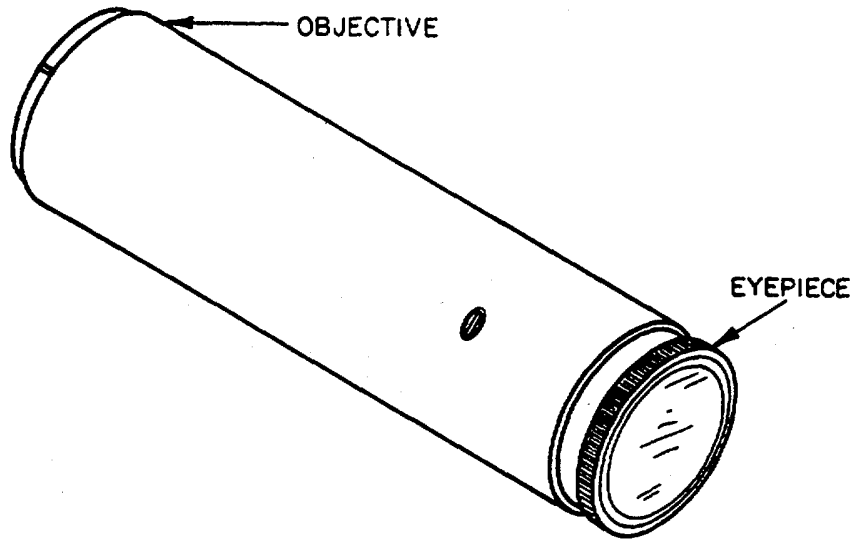

Figure 10-3. Collimating Telescope

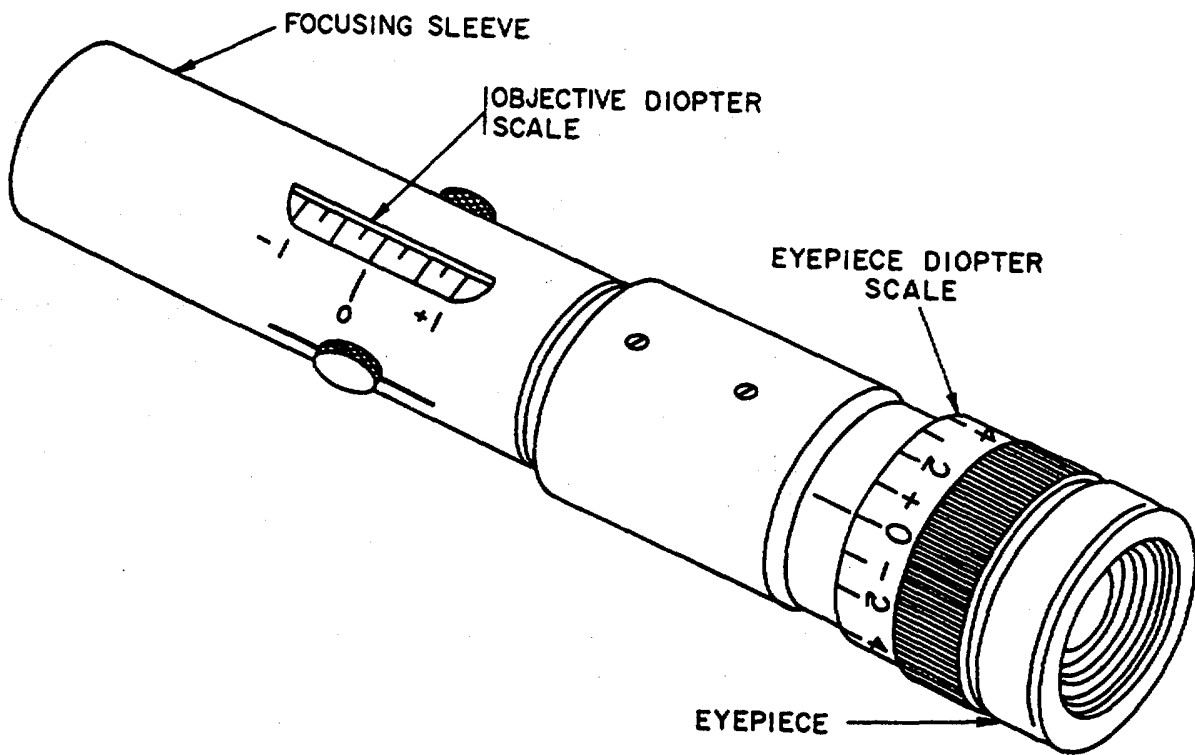

Figure 10-4. Dioptometer

#### 10-4. Dioptrimeter - Continued

b. Use. The dioptrimeter can be used for accurately setting and checking the diopter setting of fire control sighting instruments. It can also be used for checking definition of field-of-view, parallax, and astigmatism in an instrument's optical system. The dioptrimeter is placed between the eye and the instrument to be checked and the focusing sleeve is adjusted until the field-of-view is in sharp focus. The diopter setting of the instrument is then read on the objective diopter scale at the focusing sleeve. When the fixed focus eyepiece of an instrument is properly adjusted, the indication on the dioptrimeter should be  $-3/4$  to  $-1$  diopter, as read on the objective diopter scale (fig. 10-4).

### Section II. TEST FIXTURES

#### 10-5. General.

The test fixtures listed in this section are those most commonly used in the rebuild and inspection of fire control instruments. These particular test fixtures are of a universal type and with the use of special adapters each test fixture can accommodate many different fire control instruments.

#### 10-6. Azimuth Test Fixture.

a. Description. The azimuth test fixture (fig. 10-5) consists of a base, azimuth ring, vernier scale, adapter support plate, and column. It uses various mounting adapters to accommodate different fire control instruments and uses a projector collimator for a test target.

- (1) The base is cast iron having three leveling screws. It mounts and supports the other components of the fixture.
- (2) The azimuth ring is precisely machined and graduated into 6400 mils by six hundred forty engraved lines, each of which represents 10 mils. The ring can be set at any position and locked in place with a clamping arm which is mounted under the base. A spring loaded plunger and adjustment screw provides for fine adjustment of the azimuth ring.
- (3) The vernier scale mounts on the base in a machined track. It has an engraved scale consisting of fifty-one graduations. Each graduation represents 0.2 mil. Every tenth line is numbered progressively by increments of two from 0 to 10. It is possible to estimate readings as small as 0.1 mil on the vernier scale.
- (4) The column clamps to the base and supports the projector collimator.
- (5) The adapter support plate is fastened to the spindle of the azimuth ring, concentric to the ring. A machined surface perpendicular to the axis of the spindle, provides the mounting surface for the test fixture adapters. Three cam-head screws in the plate permits easy clamping of the adapters on this surface.

b. Use. The azimuth test fixture is used for adjusting and inspecting panoramic and azimuth indicating, fire control instruments such as the M-2 Aiming Circle, M117 Panoramic Telescope and the M12A7 Panoramic Telescope. Parameters that can be checked with this test fixture are; backlash in azimuth and elevation gears, level travel, azimuth and micrometer scale accuracy, and counter accuracy.

**Change 2 10-4**

## 10-6. Azimuth Test Fixture - Continued

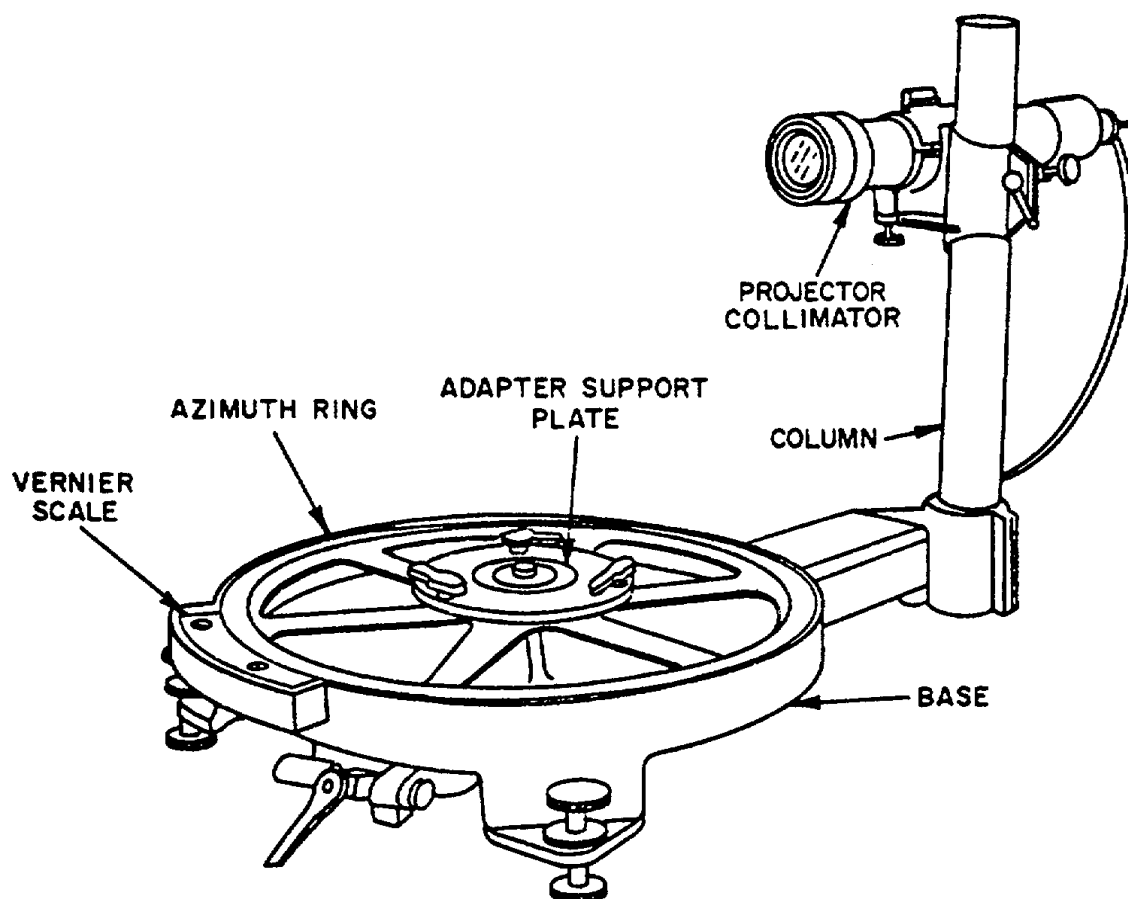

Figure 10-5. Azimuth Test Fixture

## 10-7. Telescope Test Fixture.

a. Description. The telescope test fixture (fig. 10-6) consists of a machined base mounting, a projector collimator, and two telescope supports. The projector collimator is fixed on one end of the base, and one telescope support is fixed on the opposite end of the base. A moveable telescope support is mounted on a machined track which can be adjusted to accommodate different instruments. Various adapters (fig. 10-7) are used with the fixture to accommodate straight tube and elbow telescopes. Setup gage blocks and locating blocks (fig. 10-8) are also provided to properly position the particular telescope to be tested. The adapters, setup gage blocks, and locating blocks are all marked with a lettering system, and a chart is furnished to give the proper combination of accessories to be used with the specific telescopes.

b. Use. The telescope test fixture is used for the adjustment and inspection of elbow and straight tube telescopes. Some of the instruments that are checked with this fixture are the M-97 Straight Tube Telescope, M-90F Telescope, and the M-16 Elbow Telescope. This test fixture can also be used to roll test certain instruments such as the Nike Radar Telescope or the Collimating Telescope. This is accomplished by superimposing the telescope reticle on the reticle of the projector collimator. The telescope is then rotated 180 degrees and it should be noted how far the reticle in the telescope has moved up or down from its original position.

10-7. Telescope Test Fixture - Continued

Remove one half the error by adjusting the reticle in the telescope, then remove the other half of the error with the adjustment screws on the test fixture until the two reticles are superimposed. Repeat this process until the reticles remain superimposed when rotated 180 degrees. Then rotate the telescope 90 degrees and repeat the above procedures until the reticle in the telescope is superimposed thru 360 degrees of movement.

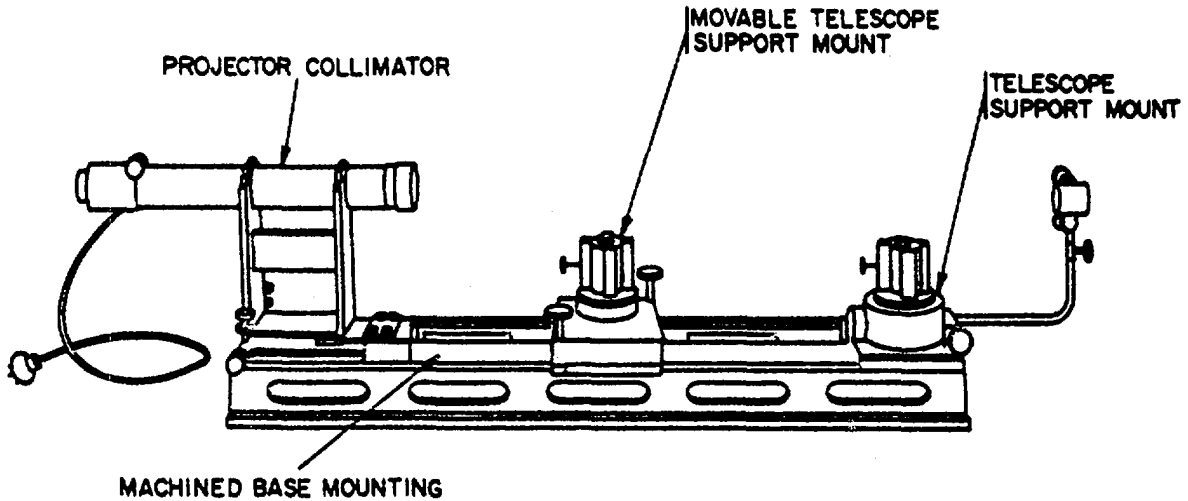

Figure 10-6. Telescope Test Fixture

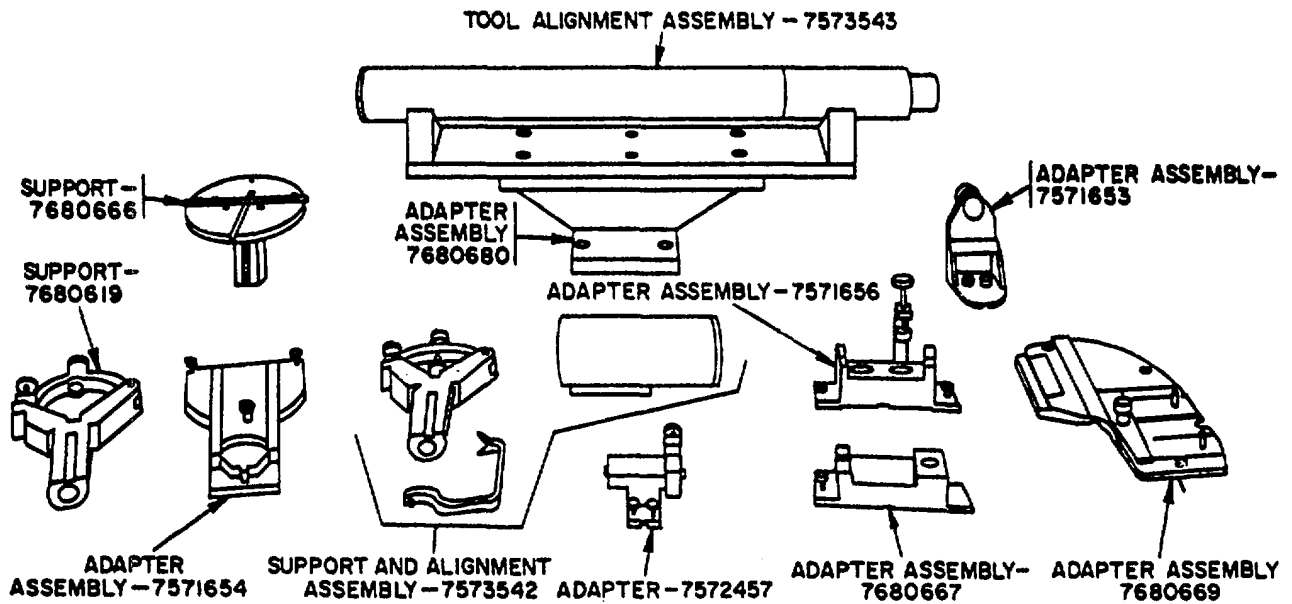

Figure 10-7. Adapter for Telescope Test Fixture.

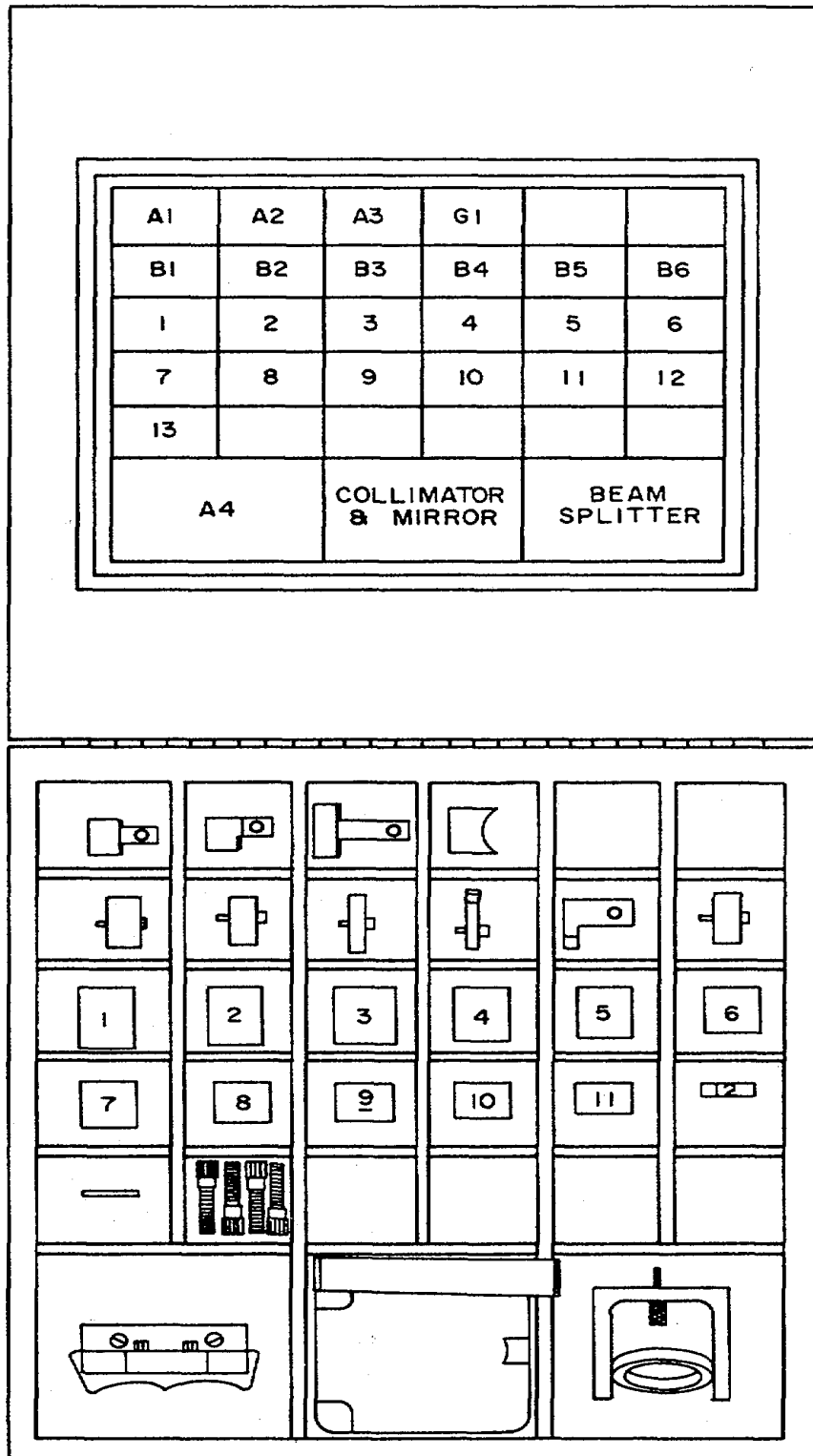

Figure 10-8. Equipment for Telescope Test Fixture



**10-8. Cross Leveling Fixture.**

a. Description. The cross leveling fixture (fig. 10-9) is made from heavy components, mainly cast iron, to reduce vibration and maintain accurate angular settings. Two large circular scales, graduated in degrees, form part of the elevation and cross leveling mechanisms of the fixture. The axes of these mechanisms lie in a horizontal plane and are fixed at right angles to each other. Each mechanism may be displaced independently upward or downward by means of worm and wormwheel movements actuated by the handwheel. Angular settings of either mechanism may be refined to minutes of arc by means of the vernier scales which form the indexes for the circular scales.

b. Use. The cross level fixture is used for the adjustment and inspection of various fire control mounts and quadrants such as the M21A1 Telescope Mount, M145 Telescope Mount, and the M15 Elevation Quadrant. The fixture was designed for checking the accuracy of elevation mechanisms, angle-of-sight mechanisms, and the setting of level vials.

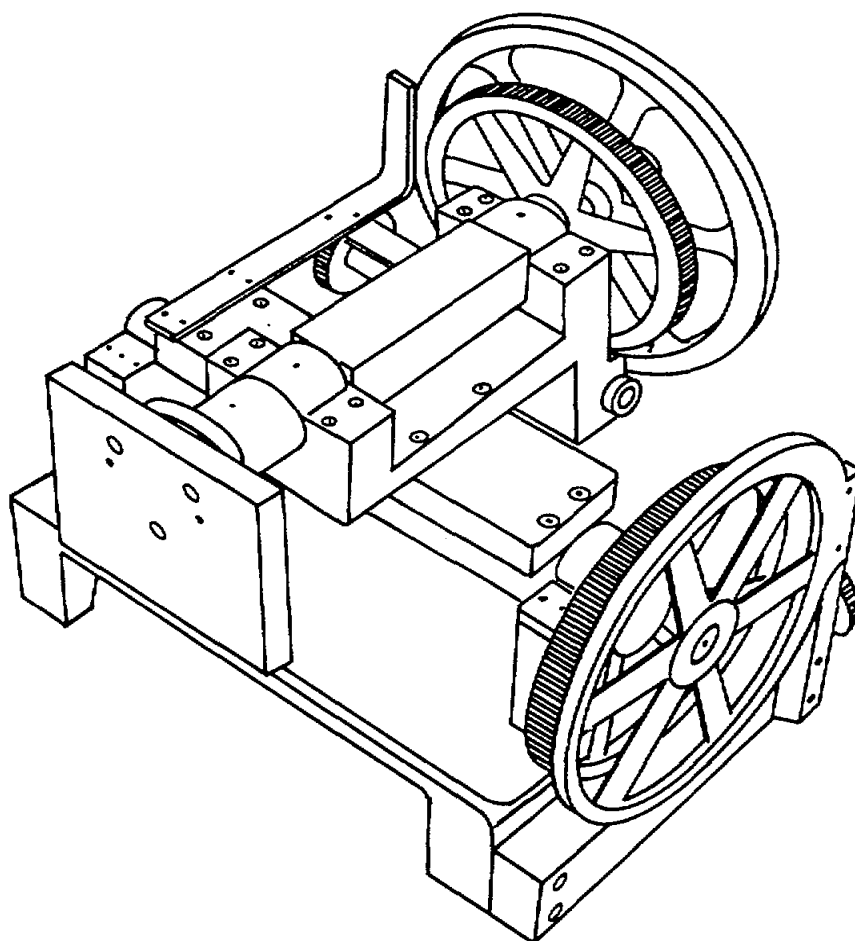

*Figure 10-9. Cross Leveling Fixture.*

### 10-9. Universal Vibration Tester.

a. Description. The universal vibration tester (fig. 10-10) is motor driven. It has a vibration table to which various adapters for fire control instruments may be secured. The amplitude and frequency of the tester are adjusted as required by the specifications for the instruments to be tested. Frequency of vibration is controlled by adjusting the weights on the vibration generator shaft. Varying the speed of the tester is accomplished by adjusting the pitch pulley which is mounted on the motor shaft of the vibrator.

b. Use. The universal vibration tester is used to simulate conditions of shock and vibration normally encountered in field use of fire control instruments. Through its use it can be determined that all parts are properly secured and that all dirt has been removed from inside the optical instrument.

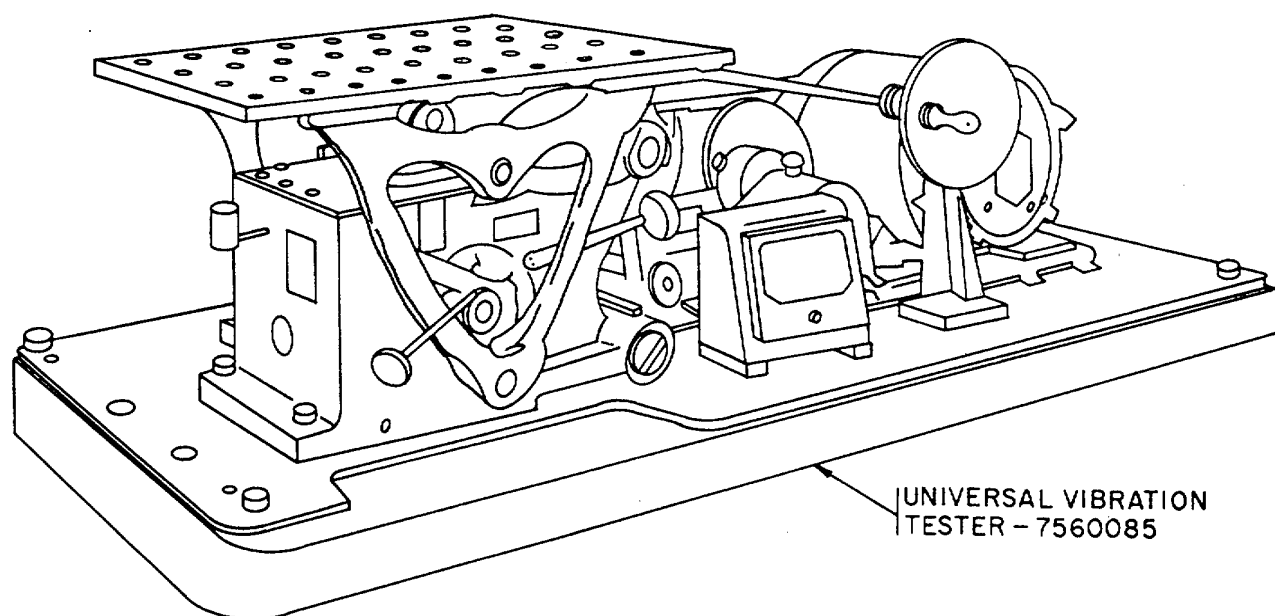

Figure 10-10. Universal Vibration Tester

### 10-10. Lens Bench.

a. Description. The lens bench shown in figure 10-11 is an instrument for measuring focal length of a single or compound lens. In addition, it can be used to test many other characteristics.

## 10-10. Lens Bench - Continued

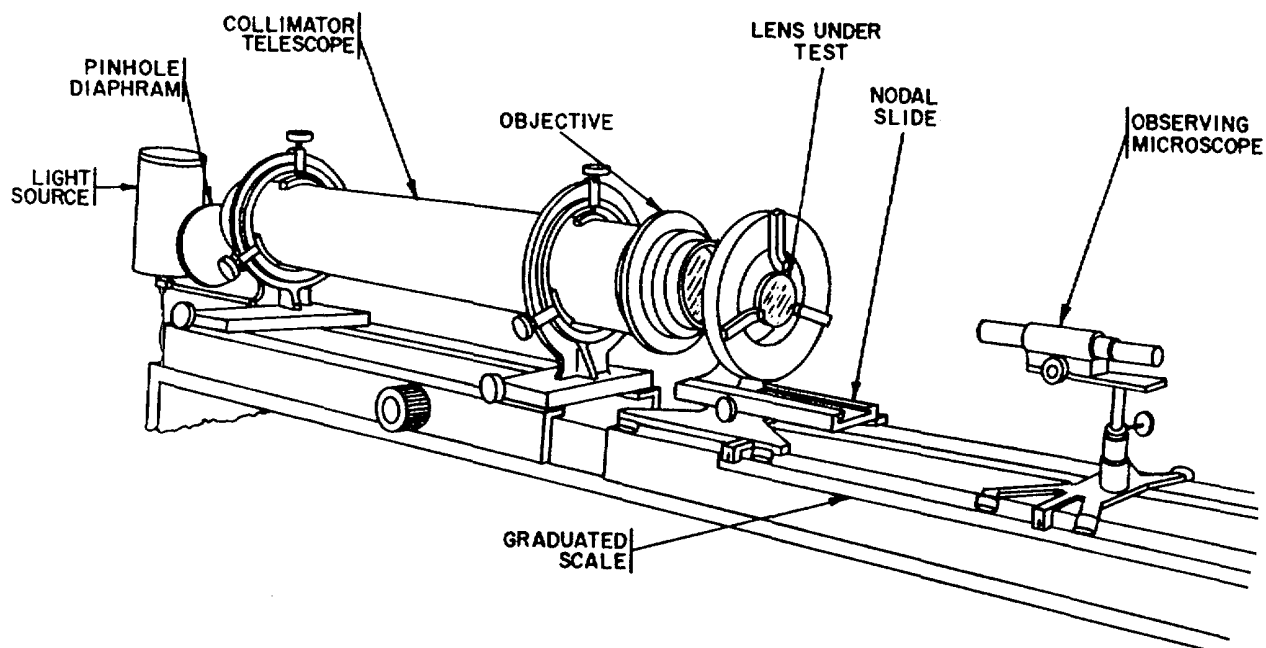

Figure 10-11. Lens Bench

- (1) The lens bench contains three main elements, the collimator telescope, the nodal slide, and the observing microscope, together with the bed on which they are mounted. The collimator and base of nodal slide are permanently mounted on the bench, while the microscope is mounted on ways which are attached to the bench. These are accurately machined and aligned, along which the microscope may be moved. The bench is equipped with a graduated scale, usually placed beneath one of the ways, while the microscope is equipped with an indicator and vernier scale so that its position can be determined to within 0.001 inch.
- (2) The collimator telescope is arranged to fulfill two functions. One is to provide a suitable source of light, usually of parallel rays, and the other to provide a proper target.
- (3) The nodal slide carries an adjustable chuck for mounting the lens under observation. The chuck is supported on the slide in such a way that it can be rotated on a vertical axis, and also can be moved longitudinally in a pair of short ways.

**10-10. Lens Bench - Continued**

- (4) The observing microscope provides the high magnification that is required to observe and study any image formed by the lens being tested, and is provided with a focusing adjustment.
  - (5) The optical axes of the microscope and the collimator must be aligned accurately and pass through the geometrical center of the chuck on the nodal slide. In addition, the ways on which the microscope slides, must be sufficiently precise so that this alignment will not be affected by any change in its location along the ways. The alignment of collimator can be corrected by adjusting screws.
- b. Uses. The lens bench is used to test lenses for the following:
- (1) Equivalent focal length. The lens to be tested is mounted in the chuck of the nodal slide, using a light clamping pressure in order to avoid straining the lens, and the azimuth of the chuck is adjusted to 0. A mark, with soft wax crayon, is placed at the center of the surface of the lens facing the microscope. The microscope is focused on the mark and the chuck is oscillated with the lens through a few degrees of azimuth on each side of 0. This oscillation will probably cause the image of the crayon in the microscope to shift laterally. Next, the chuck is moved longitudinally along its own slide, the microscope is refocused, and chuck is oscillated again. The process is repeated until a position of the lens and chuck is found which will permit the image to remain stationary while the chuck with the lens is being oscillated. When this location has been found, the image of the crayon mark is focused as sharply as possible and the location of microscope on the ways of the bench is read by means of the vernier and scale. This reading is often known as the constant of the lens bench, because it is the same for any lens tested on it.

**CAUTION**

**The microscope must not be moved by its own focusing adjustment. Move the microscope support stand along the ways of the lens bench when focusing the microscope.**

Move the microscope along the ways until it is focused on the image of the target. This setting should be corrected by oscillating the lens in the chuck, and moving the chuck and microscope in their respective ways in the same manner used previously, until the image of the target is stationary. When proper position of the chuck and the microscope is determined, the new location of the microscope on its ways is read on the scale, again using the vernier. The difference between this reading and the constant that was previously obtained is the equivalent focal length of the lens.

**10-10. Lens Bench - Continued**

- (2) Back focal length. The lens to be tested is mounted in the chuck of the nodal slide, using a light clamping pressure to avoid straining the lens, and the azimuth of the chuck is adjusted to 0. A mark with crayon is placed at center of the surface of the lens facing microscope. Then the microscope is focused on the mark as sharply as possible and the location of microscope on the ways of the bench is read by means of the vernier and scale. The next step is to move the microscope along the ways until it is focused on the image of the target. The new location of the microscope on its ways is read on the scale, again using the vernier. The difference between this reading and the reading previously obtained is the back focal length of the lens.
- (3) Spherical aberration. Spherical aberration can be measured by recording the difference between vernier scale settings of the observing microscope when focused on the image of target in the central area of the lens and again when focused on the image of the target in the outer annular area of the lens. When focusing on the center of the lens, the outer annular area is covered with a ring of opaque paper. When focusing on the outer annular area of the lens, the central area is covered with a circular disk of opaque paper.
- (4) Chromatic aberration. Chromatic aberration may be measured by illuminating the image of the target with light of a known wave length (using a filter for this purpose), focusing the microscope on the image, and reading the position of microscope on the scale. The process is repeated with different filters. The variation of the different scale positions of the microscope will give the effect of chromatic aberration of the lens with respect to the particular wave lengths used.
- (5) Astigmatism. Astigmatism can be measured by noting the difference of the settings of the observing microscope on the vernier scale, when it is focused separately on any two lines of the image of the target that are perpendicular to each other.
- (6) Coma. When the image of a point transmitted through a lens appears comet shaped when viewed through the observing microscope, the presence of coma is indicated.
- (7) Curvature of field. The amount of curvature of the field is determined by measuring the change of focus required when first focusing on the image through the axial center of the lens, and then focusing on the image through the outer field of the lens.
- (8) Distortion. The presence of distortion is indicated when the image of a line transmitted through a lens appears curved when viewed through the observing microscope.

**10-10. Lens Bench - Continued**

- (9) Eccentricity. A lens is said to be concentric when the geometrical or mechanical axis of the lens coincides with optical axis. When a lens is concentric, there will be no perceptible movement of the image when the lens is rotated about its geometrical axis. Conversely, when these two axes do not coincide, the lens is eccentric, and the amount of eccentricity is proportional to the movement of the image when it is rotated about its geometrical axis. When the optical bench is used to measure the eccentricity of a lens, the regular chuck in the nodal slide is replaced by a special chuck, which will permit the lens to be rotated freely on an axis parallel to the ways of the bench and coincidental with the axes of the collimator and microscope. When a lens is mounted in the chuck and is rotated through 360 degrees, the image of the intersection of the cross lines will trace a circle against the target, as seen in the observing microscope. The radius of this circle is directly proportional to the eccentricity of the element under observation. A convenient target for measuring the actual amount of eccentricity consists of a group of twelve concentric circles whose centers are at the center of the target and whose radii will indicate a series of deviations from 1 to 12 minutes for the particular focal length of the collimator being used.

**10-13/(10-14 blank)**

**APPENDIX A**  
**REFERENCES**

---

**A-1. Scope.**

This appendix lists all forms, field manuals, technical manuals, and miscellaneous publications referenced in this manual.

**A-2. Forms.**

Quality Deficiency Report.....	SF 368
Serviceable Tag.....	DD Form 1574
Unserviceable (Condemned) Tag.....	DD Form 1577
Unserviceable (Repairable) Tag.....	DD Form 1755-2
Equipment Inspection and Maintenance Worksheet.....	DA Form 2404

**A-3. Field Manuals.**

First Aid for Soldiers.....	FM 21-11 (TEST)
-----------------------------	-----------------

**A-4. Technical Manuals.**

Use and Care of Handtools and Measuring Tools.....	TM 9-243
Administrative Storage.....	TM 740-90-1
General Procedures for Purging and Charging Fire Control Instruments.....	TM 750-116

**A-5. Miscellaneous Publications.**

Graphic Symbols for Electrical and Electronic Diagrams.....	ANSI Y32.2
Accident Reporting and Records.....	AR 385-40
Graphic Symbols for Logic Diagrams.....	MIL-STD-806
Maintenance Inspection Standard for Fire Control Equipment.....	MIS TOE 102
Storage Serviceability Standards for USAWECOM Materiel.....	SB 740-95-601
Notices, Instructions, and Reports to Workers; Inspections.....	10 CFR Part 19
Standards for Protection Against Radiation.....	10 CFR Part 20

**A-6. Regulations.**

The Army Maintenance Management System.....	DA PAM 738-750
---	----------------

APPENDIX B

EXPENDABLE SUPPLIES AND MATERIALS LIST

Section I. INTRODUCTION

B-1. Scope.

This appendix lists expendable supplies and materials you will need to operate and maintain Fire Control Materiel. These items are authorized to you by CTA 50-970, Expendable items (except Medical, Class V, Repair Parts, and Heraldic items).

B-2. Explanation of Columns.

- a. Column (1) - National Stock Number. This is the National stock number assigned to the item; use it to request or requisition the item
- b. Column (2) - Description. Indicates the Federal item name and, if required a description to identify the item. The last line for each indicates the Federal Supply Code for Manufacturer (FSCM) in parentheses followed by the part number.
- c. Column (3) - Unit of Measure (U/M) Indicates the measure used in performing the actual maintenance function. This measure is expressed by a two-character alphabetical abbreviation (e.g., EA, IN, PR). If the unit measure differs from the unit of issue, requisition the lowest unit of issue that will satisfy your requirements.

Section II. EXPENDABLE SUPPLIES AND MATERIALS LIST

(1) National Stock Number	(2) Description	(3) U/M
6810-00-184-4795	Acetone, technical, liquid form (81348) O-A-51	CN
6810-00-264-6535	Acid, boric (81348) O-C-265	CN
6810-00-227-1845	Acid, sulfuric, technical (96906) MIL-STD-605	CN
8040-00-059-5477	Adhesive, plastic, epoxy (81348) MMM-A-134	CN
	Adhesive, optical, part A K73857	BT
	Adhesive, optical, part B K73858	BT
8040-00-664-4318	Adhesive, rubber, type II (81348) MMM-A-1617	CN



## Section II. EXPENDABLE SUPPLIES AND MATERIALS LISTS - Continued

(1) National Stock Number	(2) Description	(3) U/M
6810-00-201-0906	Alcohol, denatured (81348) OE760	PT
9535-00-752-9061	Aluminum, foil (81348) QQ-A-1876	RO
8105-00-296-4662	Bags, polyethylene (81349) MIL-B-177	EA
7920-00-514-2417	Brush, acid swabbing (81348) H-B-643	EA
8020-00-224-8022	Brush, artist's (81348) H-B-118	EA
6850-00-227-1887	Cleaning compound, optical lens, type 1 (81349) MIL-C-43454	QT
8305-00-286-5461	Cloth, batiste (lint-free) white, 39 1/2 inches wide (81349) MIL-C-40129	YD
8305-00-205-3494	Cloth, cheese, bleached, type II (81349) CCC-C-440	RO
7930-00-985-6911	Detergent, general purpose	
3439-00-400-1971	Flux, soldering (81348) MIL-F-14256	PT
5350-00-271-5966	Lapping compound, grit 120 (81348) SSL 1682	CN
	Magnesium fluoride MIL-C-675C	
6830-00-656-1596	Nitrogen, technical (81349) BB-N-411	CY
6640-00-597-6745	Paper, lens, type I, block of 50 (80244) NNN-P-40	EA
6640-00-285-4694	Paper, lens, wrapping (80244) NNN-P-40	EA
7920-00-205-1711	Rag, wiping, 50 pound bale 58536) A-A-531	LB

Section II. EXPENDABLE SUPPLIES AND MATERIALS LISTS - Continued

(1) National Stock Number	(2) Description	(3) U/M
3439-00-453-5473	Soldering, lead tin alloy (81348) QQ-S-571	LB
3439-00-269-9610	Solder, tin alloy, lead tin alloy and lead alloy, (81348) QQ-S-571	LB
6850-00-274-5421	Solvent, Dry Cleaning, SD2, type II P-D-680	
7510-00-106-7355	Tape, double sided, 3 inch wide, 1296 foot roll, (81348) UU-T-91	RO
4020-00-789-0802	Tape, lacing, nylon, type I, size 2 (81349) MIL-T-43435	SP
7510-00-266-6712	Tape, masking, pressure sensitive (19203) 8783476	RO

**APPENDIX C**  
**FABRICATED ITEMS**

**C-1. Fabricated Tools and Adapter.**

The fabricated tools and adapter used in this manual are listed in table C-1.

*Table C-1. Fabricated Tools and Adapter*

Nomenclature	Reference		Material required
	para	fig.	
Adapter, leak test	3-23	C-1	Aluminum, QQ-A-200
Eccentric, one piece	3-8	C-2	Steel, QQ-T-580
Eccentric, two piece	3-8	C-3	Steel, QQ-T-580

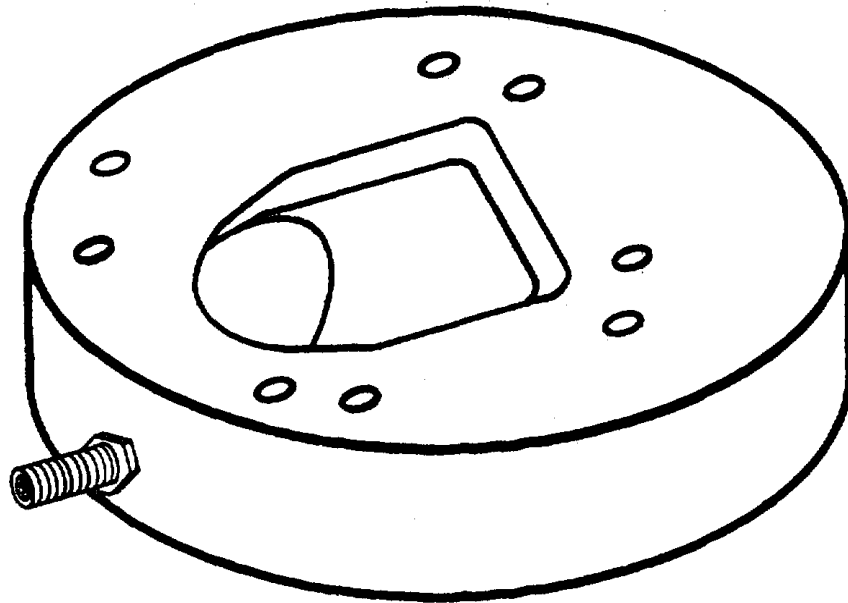

*Figure C-1. Leak Test Adapter (Sheet 1 of 2)*

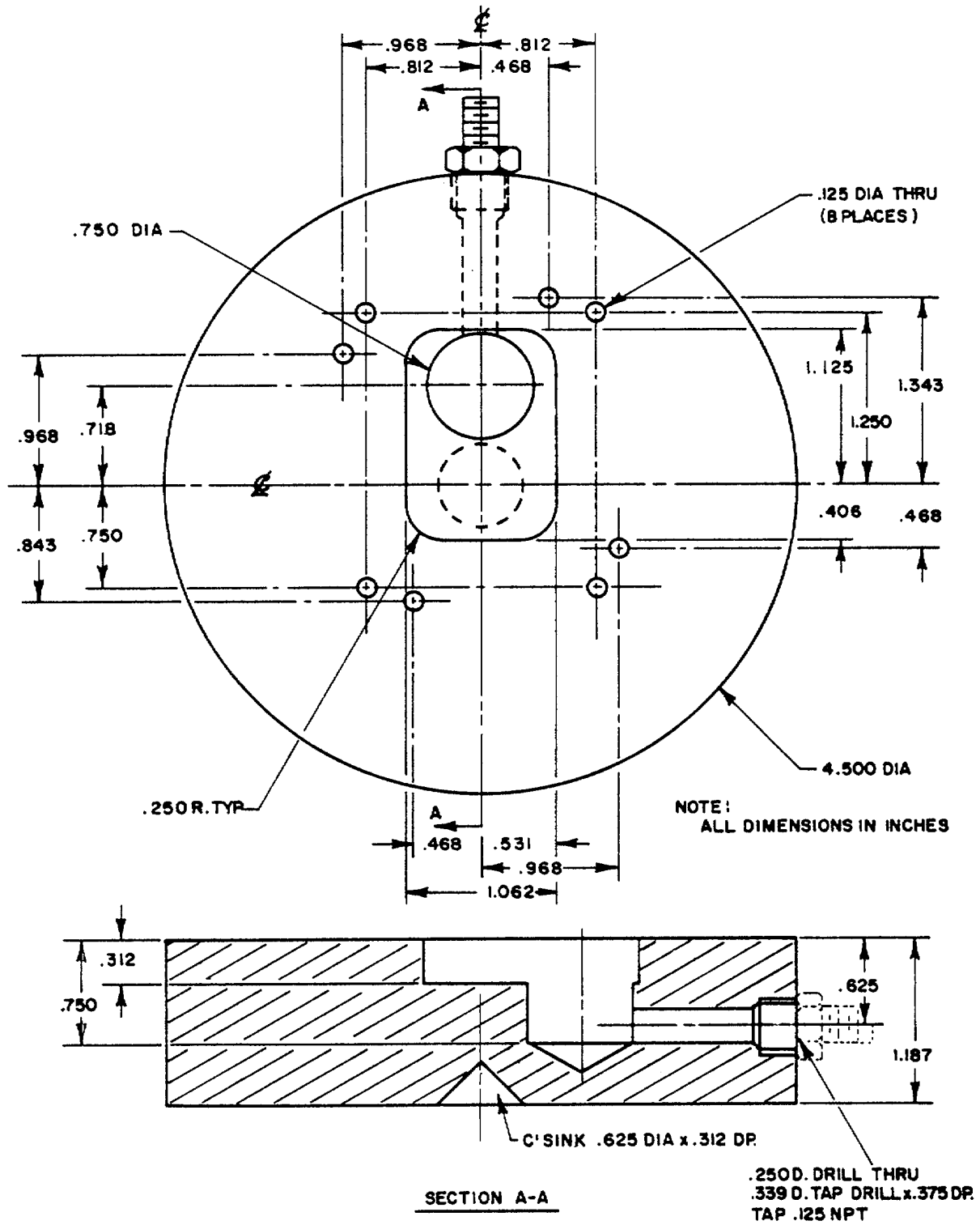
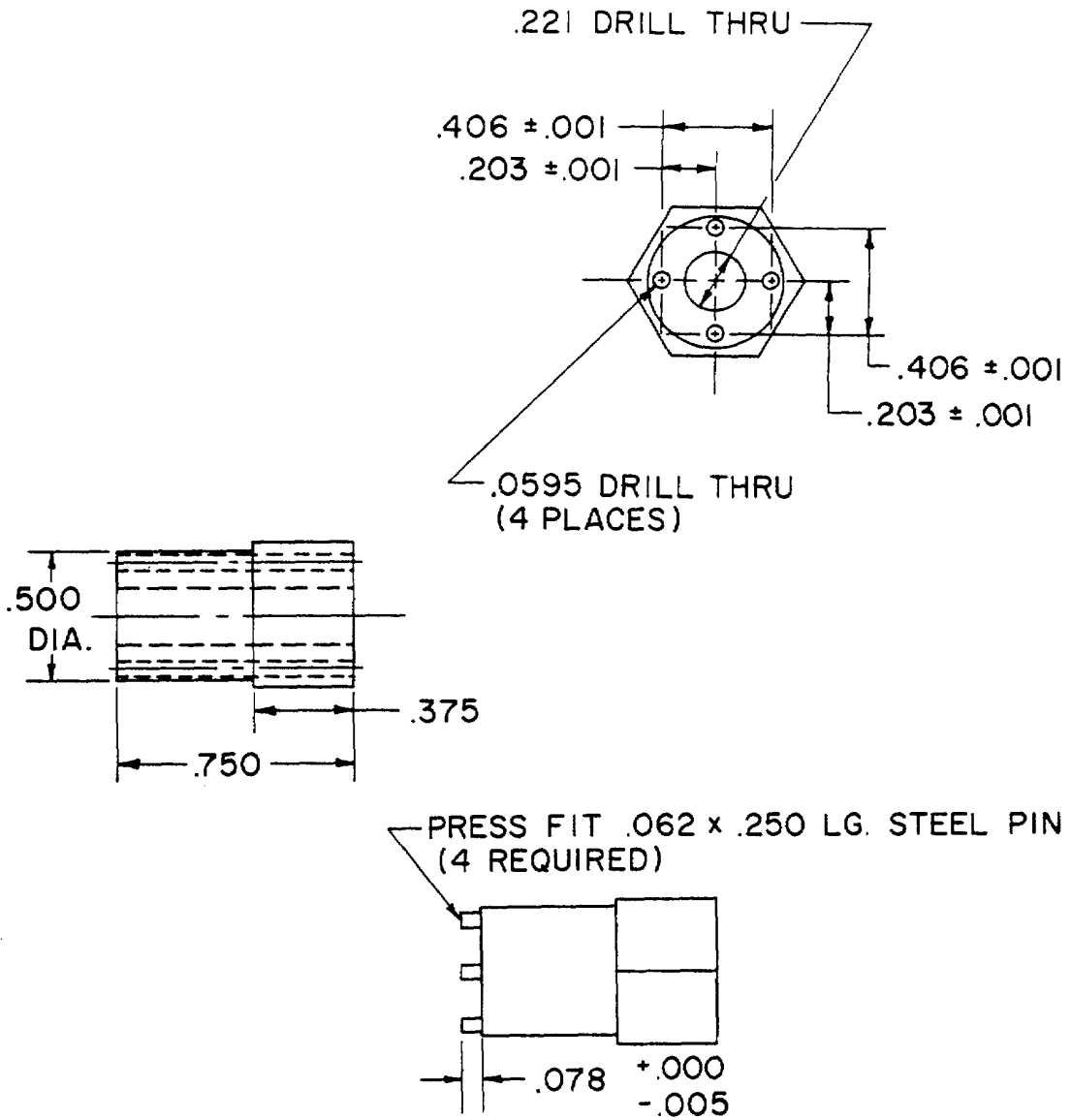

Figure C-1. Leak Test Adapter (Sheet 2 of 2)



NOTES:

1. DIMENSIONS  $\pm$  .010 UNLESS OTHERWISE STATED.
2. REMOVE BURRS AND BREAK ALL SHARP EDGES.

MATERIAL:

9/16 HEX STOCK C.R.S. QQ-T-580.

Figure C-2. One Piece Eccentric Tool

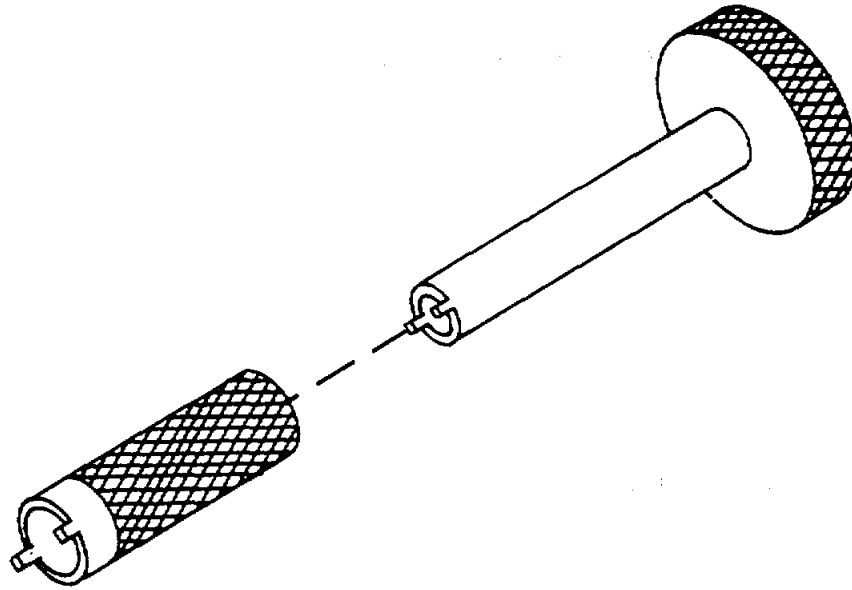
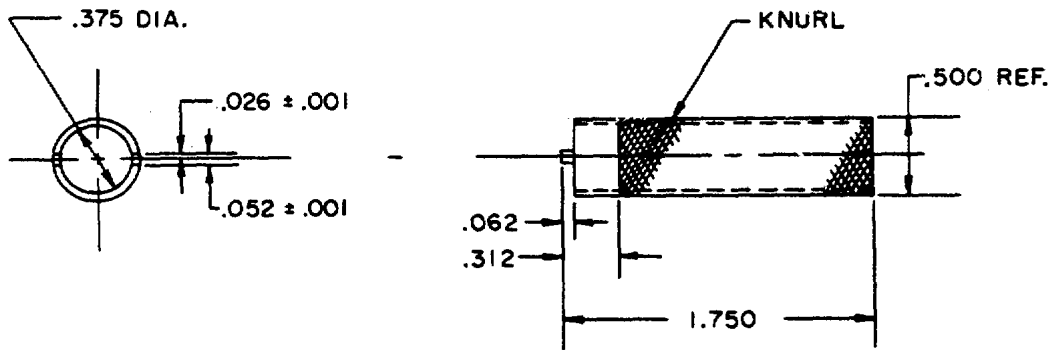
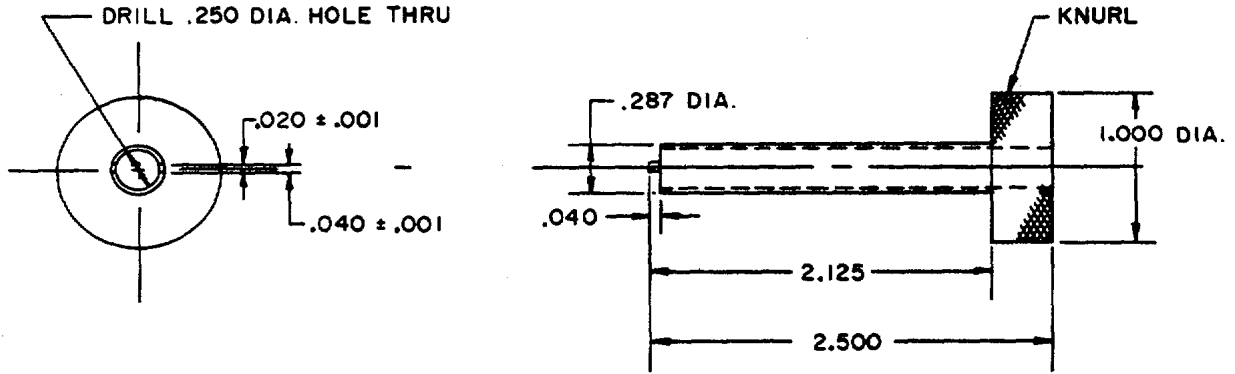

Figure C-3. Two Piece Eccentric Tool (Sheet 1 of 2)



- NOTES:
1. REMOVE BURRS AND BREAK ALL SHARP EDGES.
  2. ALL DIMENSIONS ARE IN INCHES UNLESS OTHERWISE STATED.



- NOTES:
1. REMOVE BURRS AND BREAK ALL SHARP EDGES.
  2. ALL DIMENSIONS ARE IN INCHES UNLESS OTHERWISE STATED.

Figure C-3. Two Piece Eccentric Tool (Sheet 2 of 2)

C-5/(C-6 blank)

APPENDIX D

LIST OF APPLICABLE PUBLICATIONS

---

**D-1. Scope.**

This appendix lists publications that are not referenced in this manual, but may be used to supplement the procedures contained herein.

**D-2. Technical Manuals.**

Materials Used for Cleaning, Preserving, Abrading, and Cementing Material, Including Chemical.....	TM 9-247
Elementary Optics and Application to Fire Control Instruments.....	TM 9-258
Organizational, DS, GS, and Depot Maintenance Manual Multimeter TS-352 B/U.....	TM 11-6625-366-15 C2
Calibration Procedures for AN/USM 281 .....	TM 11-6625-1703-50 C1
Oscilloscope AN/USM-281C.....	TM 11-6625-2658-14

**D-3. Miscellaneous Publications.**

- Optical Elements for Fire Control Instruments by  
Anderson, Nichols Associates
- Solder ... its fundamentals and usage by Kester Solder Company

**Change 2 D-1/(D-2 blank)**



INDEX

	Para	Page
<b>A</b>		
Abrasive Process .....	4-20	4-49
Alternating Current .....	7-3	7-4
Azimuth Test Fixture .....	10-6	10-4
<b>B</b>		
Basic Troubleshooting Procedure .....	7-11	7-22
<b>C</b>		
Capacitor Identification .....	7-5	7-10
Care of Scribes .....	4-10	4-25
Cementing Optical Components .....	9-10	9-34
Cleaning Optical Components .....	9-3	9-13
Coating Optical Components .....	9-9	9-25
Coding Wires .....	6-4	6-2
Collimator Telescope .....	10-3	10-2
Connector Contact Pins .....	6-10	6-11
Connector Familiarization .....	6-7	6-5
Connector Maintenance .....	6-8	6-6
Conversion Factors .....	5-4	5-4
Cross Leveling Fixture .....	10-8	10-8
<b>D</b>		
Decementing (Separation) Optical Components .....	9-7	9-23
Decoating Optical Components .....	9-8	9-25
Degree System .....	5-7	5-16
Desoldering Techniques .....	4-14	4-35
Dioptometer .....	10-4	10-2
Direct Current .....	7-2	7-1
Direct Current (DC) Power Supply .....	8-8	8-23
<b>E</b>		
Electronic Component Schematic Symbols .....	7-9	7-18
Equipment Characteristics, Capabilities, and Features .....	1-4	1-1

INDEX - Continued

	Para	Page
<b>F</b>		
Field Report of Accidents .....	2-3	2-2
Files .....	4-22	4-52
<b>G</b>		
General Safety Items and Actions .....	2-4	2-2
Grinding Chipped Windows .....	4-24	4-56
<b>H</b>		
Half-Splitting Method of Troubleshooting .....	7-13	7-24
Handling Expendables .....	3-12	3-31
Harness Lacing .....	6-5	6-3
Helical Inserts .....	3-9	3-26
<b>I</b>		
Induction Heat Soldering .....	4-19	4-49
Inductor Identification .....	7-6	7-13
Inspecting Optical Components .....	9-6	9-20
<b>L</b>		
Lapping .....	4-21	4-50
Lens Bench .....	10-10	10-9
Level Assembly and Cover Assembly Leakage Test .....	3-23	3-50
Level Vials .....	3-8	3-21
Logic Component Schematic Symbols .....	7-10	7-21
<b>M</b>		
Maintenance Forms, Records, and Reports .....	1-2	1-2
Marking Optical Components .....	9-5	9-18
Measurement Units .....	5-3	5-2
Multimeter Familiarization .....	8-3	8-8
Meter Usage .....	8-2	8-2
Metric Prefixes .....	5-2	5-1
Mil System .....	5-8	5-17
Military Fuse Identification .....	7-8	7-16

## INDEX - Continued

	Para	Page
<b>O</b>		
Optical Components .....	9-2	9-5
Optical Terms .....	9-1	9-1
Oscilloscope Familiarization .....	8-5	8-11
Oscilloscope Probes .....	8-7	8-21
<b>P</b>		
Peening .....	3-5	3-8
Preparing Wires .....	6-2	6-1
Printed Circuit Boards .....	4-17	4-40
Projector Collimator .....	10-2	10-1
Purging and Charging .....	3-22	3-48
<b>R</b>		
Reconditioning Damaged Tapered Holes .....	3-2	3-3
Removing Nicks and Burrs .....	4-23	4-54
Removal of Setscrews .....	3-10	3-29
Reporting Equipment Improvement Recommendations .....	1-3	1-1
Resistance Soldering .....	4-18	4-46
Resistor Identification .....	7-4	7-9
<b>S</b>		
Safety, Care, and Handling .....	1-5	1-1
Safety Wiring Procedures .....	6-11	6-16
Scale Interpretation .....	8-4	8-10
Screw Thread .....	5-9	5-21
Scribers .....	4-7	4-23
Semiconductor Identification .....	7-7	7-14
Set Up of Purging and Charging Equipment .....	3-18	3-43
Short Term Shutdown of Purging and Charging Equipment .....	3-19	3-47
Soldering .....	4-11	4-25
Soldering Station .....	4-12	4-25
Soldering Techniques .....	4-13	4-28
Solderless Connectors .....	6-9	6-8
Staking .....	3-4	3-4
Standards of Length .....	4-6	4-17
Storage Containers .....	3-16	3-42
Storing and Handling Optical Components .....	9-4	9-17
Storing Expendables .....	3-14	3-41
Stripping Insulated Wire .....	4-15	4-36
Swaging .....	3-6	3-9

INDEX - Continued

	Para	Page
<b>T</b>		
Tagging.....	6-13	6-21
Tapered Pins and Tapered Holes .....	3-1	3-1
Telescope Test Fixture.....	10-7	10-5
Temperature Conversion.....	5-6	5-15
Temperature Scales .....	5-5	5-14
Thread Chasers.....	4-25	4-57
Time Cycles.....	3-20	3-47
Tinning Wire .....	4-16	4-38
Torque Wrench .....	4-1	4-1
Troubleshooting with the Technical Manual.....	7-12	7-22
Types of Maintenance Forms.....	2-2	2-1
Types of Meters.....	8-1	8-1
Types of Rules.....	4-4	4-14
Types of Scribes .....	4-8	4-24
<b>U</b>		
Universal Vibration Tester .....	10-9	10-9
U.S. and Metric Measurement Data .....	5-1	5-1
Use of Gages .....	4-2	4-7
Use of Pin Boards .....	6-3	6-2
Using Expendables.....	3-13	3-31
Using the Rule.....	4-5	4-15
Using the Scriber .....	4-9	4-24
<b>W</b>		
Waveform Reading .....	8-6	8-17
Wire Gage .....	5-10	5-26
Worm and Worm Gear Mechanisms .....	3-7	3-12

By Order of the Secretary of the Army:

JOHN A. WICKHAM, JR.  
*General, United States Army*  
*Chief of Staff*

Official:

ROBERT M. JOYCE  
*Major General, United States Army*  
*The Adjutant General*

Distribution:

To be distributed in accordance with DA Form 12-34c, requirements for TB 43 series: AMCCOM.

☆U.S. GOVERNMENT PRINTING OFFICE: 1996 - 406-421 (61190)

RECOMMENDED CHANGES TO EQUIPMENT TECHNICAL PUBLICATIONS



THEN... JOT DOWN THE DOPE ABOUT IT ON THIS FORM, CAREFULLY TEAR IT OUT, FOLD IT AND DROP IT IN THE MAIL!

**SOMETHING WRONG WITH THIS PUBLICATION?**

FROM: (PRINT YOUR UNIT'S COMPLETE ADDRESS)

DATE SENT

PUBLICATION NUMBER

PUBLICATION DATE

PUBLICATION TITLE

BE EXACT... PIN-POINT WHERE IT IS

PAGE NO.

PARA-GRAPH

FIGURE NO.

TABLE NO.

IN THIS SPACE TELL WHAT IS WRONG AND WHAT SHOULD BE DONE ABOUT IT:

TEAR ALONG PERFORATED LINE

PRINTED NAME, GRADE OR TITLE, AND TELEPHONE NUMBER

SIGN HERE:

DA FORM 2028-2  
1 JUL 79

PREVIOUS EDITIONS ARE OBSOLETE.

P.S.—IF YOUR OUTFIT WANTS TO KNOW ABOUT YOUR RECOMMENDATION MAKE A CARBON COPY OF THIS AND GIVE IT TO YOUR HEADQUARTERS.

## THE METRIC SYSTEM AND EQUIVALENTS

### LINEAR MEASURE

1 Centimeter = 10 Millimeters = 0.01 Meters = 0.3937 Inches  
 1 Meter = 100 Centimeters = 1000 Millimeters = 39.37 Inches  
 1 kilometer = 1000 Meters = 0.621 Miles

### WEIGHTS

1 Gram = 0.001 Kilograms = 1000 Milligrams = 0.035 Ounces  
 1 Kilogram = 1000 Grams = 2.2 Lb.  
 1 Metric Ton = 1000 Kilograms = 1 Megagram = 1.1 Short Tons

### LIQUID MEASURE

1 Milliliter = 0.001 Liters = 0.0338 Fluid Ounces  
 1 Liter = 1000 Milliliters = 33.82 Fluid Ounces

### SQUARE MEASURE

1 Sq. Centimeter = 100 Sq. Millimeters = 0.155 Sq. Inches  
 1 Sq. Meter = 10,000 Sq. Centimeters = 10.76 Sq. Feet  
 1 Sq. Kilometer = 1,000,000 Sq. Meters = 0.386 Sq. Miles

### CUBIC MEASURE

1 Cu. Centimeter = 1000 Cu. Millimeters = 0.06 Cu. Inches  
 1 Cu. Meter = 1,000,000 Cu. Centimeters = 35.31 Cu. Feet

### TEMPERATURE

$5/9 (^{\circ}\text{F} - 32) = ^{\circ}\text{C}$   
 212° Fahrenheit is equivalent to 100° Celsius  
 90° Fahrenheit is equivalent to 32.2° Celsius  
 32° Fahrenheit is equivalent to 0° Celsius  
 $9/5 (^{\circ}\text{C} + 32) = ^{\circ}\text{F}$

### APPROXIMATE CONVERSION FACTORS

TO CHANGE	TO	MULTIPLY BY
Inches .....	Centimeters .....	2.540
Feet .....	Meters .....	0.305
Yards .....	Meters .....	0.914
Miles .....	Kilometers .....	1.609
Square Inches .....	Square Centimeters .....	6.451
Square Feet .....	Square Meters .....	0.093
Square Yards .....	Square Meters .....	0.836
Square Miles .....	Square Kilometers .....	2.590
Acres .....	Square Hectometers .....	0.405
Cubic Feet .....	Cubic Meters .....	0.028
Cubic Yards .....	Cubic Meters .....	0.765
Fluid Ounces .....	Milliliters .....	29.573
Pints .....	Liters .....	0.473
Quarts .....	Liters .....	0.946
Gallons .....	Liters .....	3.785
Ounces .....	Grams .....	28.349
Pounds .....	Kilograms .....	0.454
Short Tons .....	Metric Tons .....	0.907
Pound-Feet .....	Newton-Meters .....	1.356
Pounds per Square Inch .....	Kilopascals .....	6.895
Miles per Gallon .....	Kilometers per Liter .....	0.425
Miles per Hour .....	Kilometers per Hour .....	1.609
TO CHANGE	TO	MULTIPLY BY
Centimeters .....	Inches .....	0.394
Meters .....	Feet .....	3.280
Meters .....	Yards .....	1.094
Kilometers .....	Miles .....	0.621
Square Centimeters .....	Square Inches .....	0.155
Square Meters .....	Square Feet .....	10.764
Square Meters .....	Square Yards .....	1.196
Square Kilometers .....	Square Miles .....	0.386
Square Hectometers .....	Acres .....	2.471
Cubic Meters .....	Cubic Feet .....	35.315
Cubic Meters .....	Cubic Yards .....	1.308
Milliliters .....	Fluid Ounces .....	0.034
Liters .....	Pints .....	2.113
Liters .....	Quarts .....	1.057
Liters .....	Gallons .....	0.264
Grams .....	Ounces .....	0.035
Kilograms .....	Pounds .....	2.205
Metric Tons .....	Short Tons .....	1.102
Newton-Meters .....	Pound-Feet .....	0.738
Kilopascals .....	Pounds per Square Inch .....	0.145
Kilometers per Liter .....	Miles per Gallon .....	2.354
Kilometers per Hour .....	Miles per Hour .....	0.621

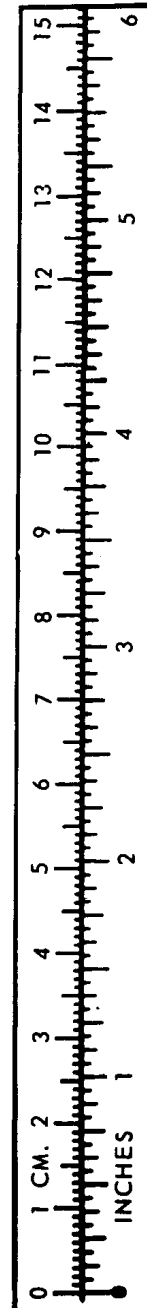

**PIN: 026333-006**